



"Radial" Cutter
(STANDARD)



"Slicer"
(OPTION)

KHHG2(H)(X)

Centrifugal Grinder Series
(CLASS 1, DIV. 1, GROUPS C &
D HAZARDOUS LOCATION)

**Heavy-Duty Recessed Impeller
Pump Provides Reliable Service
for The Low Pressure Sewer Industry!**

HIGHEST PERFORMANCE GRINDERS
HIGH FLOW & HIGH HEAD

- Flows to 30 GPM
- Pressure to 225 Feet
- **SILICON CARBIDE DUAL SEALS**
- Handles Extreme Operating Conditions
- **BEST MOTOR DESIGN**
- Motor Pressed Housing For Superior Heat Transfer
- Long Bearing & Seal Life
- **HAZARDOUS LOCATION DESIGN**
- True "Explosion-Proof" Service



“Slicer” Cutter
Preventing Jamming
on Solids

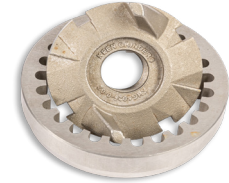

“Radial” Cutter
50 Year Proven
Design

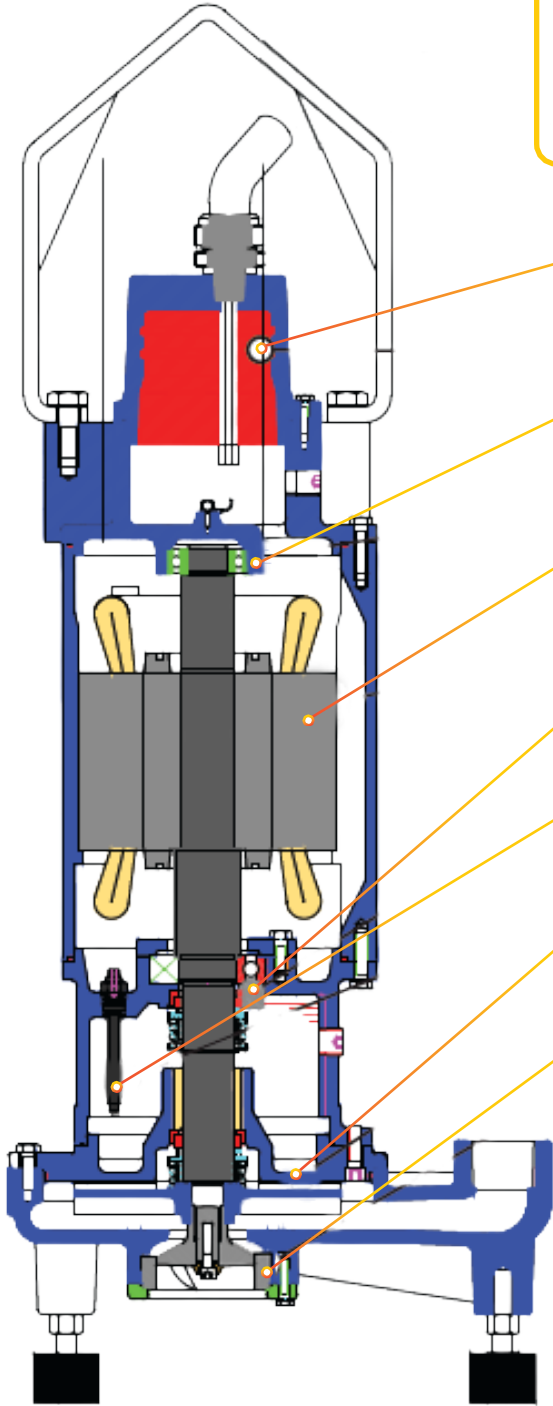

EPOXY-POTTED CORD ENTRY

- Triple-Barrier Moisture Protection

3-BEARING SUPPORT

- Upper/Lower Ball Bearing
- Additional Lower Sleeve Bearing

HIGH-TORQUE MOTOR COOLED FOR SUPERIOR HEAT DISSIPATION

SUPERIOR DUAL MECHANICAL SEALS- SILICON CARBIDE W/VITON ELASTOMERS

SEAL LEAK DETECTION

RECESSED, VORTEX IMPELLER, DUCTILE IRON

- Allows 100% Performance Curve Operation

PROVEN GRINDER ASSEMBLY

- Highly Efficient Solids-Cutting
- Hardened SST (Rockwell 56-60)
- Reversible Grinder Ring
- User-Friendly Field Service

KHHG2H = HIGH HEAD

KHHG2 = HIGH FLOW

KHHG2(H)X = EXPLOSION PROOF

2HP SUBMERSIBLE GRINDER PUMP

GENERAL		MOTOR DATA	
Pump Model	KHHG2	HP / Power Supply	2HP / 1 ϕ , 60 Hz
		Full Load Amps 208V	28 Amps
PUMP DATA		Start Amps 208V	100 Amps
Date	09/2022	Full Load Amps 230V	25 Amps
Discharge Flange	1-1/4" NPT, Horizontal or Vertical	Start Amps 230V	89 Amps
Grinder Construction	Stainless Steel	Full Load Amps/ Start Amps 240V	9 Amps/ 45 Amps
Grinder Hardness	58 - 60 Rockwell	Poles / Rated Speed	2 P / 3450 rpm
Impeller Type	Semi - Open	Insulation Class	N Class
SINGLE PHASE/ THREE PHASE	START KIT SK-KG5 includes: Start & Run Capacitors, Relay, and Mounting Hardware	Start Capacitor	216 ufd, 250 VAC
		Run Capacitor	20 ufd, 370 VAC

PERFORMANCE CURVE

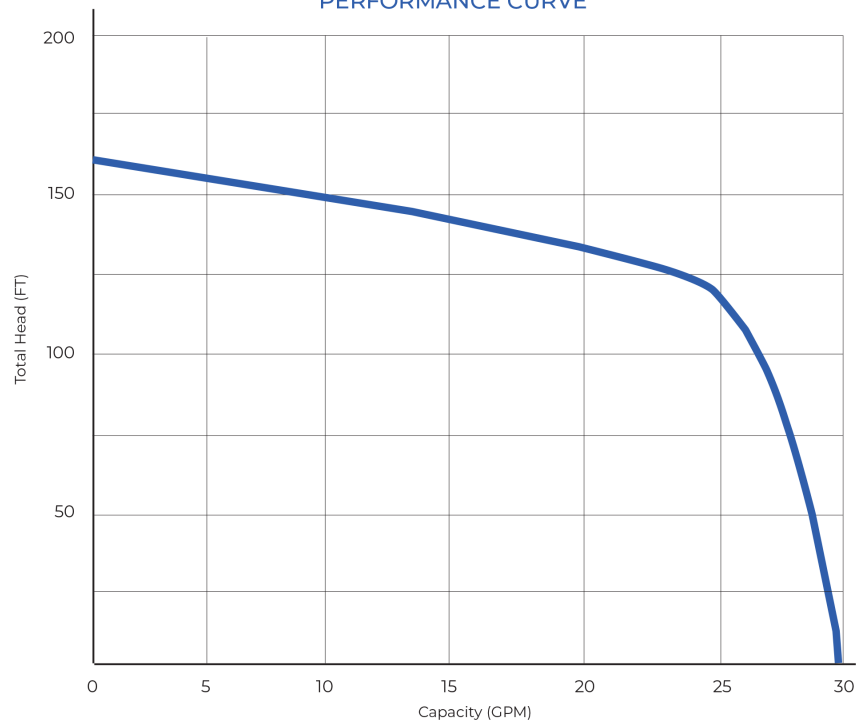

MODEL (HIGH FLOW RADIAL CUTTER)	HP	VOLTS	PHASE	NEC CODE	SERVICE FACTOR	FULL LOAD AMPS	START AMPS	FULL LOAD KW	FULL LOAD KVA
KHHG2-2001	2	208	1	G	1.0	28.0	100.0	4.95	7.00
KHHG2-2301	2	230	1	G	1.0	25.0	89.0	4.89	7.18
KHHG2-2401	2	240	1	G	1.0	9.0	45.0	4.89	7.18
KHHG2-2003	2	208	3	H	1.0	21.0	105.0	6.43	7.56
KHHG2-2303	2	230	3	H	1.0	18.0	90.0	6.10	7.17
KHHG2-4603	2	460	3	H	1.0	9.0	45.0	6.10	7.17

2HP SUBMERSIBLE GRINDER PUMP

GENERAL		MOTOR DATA	
Pump Model	KHHG2H	HP / Power Supply	2HP / 1 ϕ , 60 Hz
PUMP DATA		Full Load Amps 208V	42 Amps
Date	09/2022	Start Amps 208V	148 Amps
Discharge Flange	1-1/4" NPT, Horizontal or Vertical	Full Load Amps 230V	40 Amps
Grinder Construction	Stainless Steel	Start Amps 230V	142 Amps
Grinder Hardness	58 - 60 Rockwell	Full Load Amps/ Start Amps 240V	12.5 Amps/ 44 Amps
Impeller Type	Semi - Open	Poles / Rated Speed	2 P / 3450 rpm
SINGLE PHASE/ THREE PHASE	START KIT SK-KG5 includes: Start & Run Capacitors, Relay, and Mounting Hardware	Insulation Class	N Class
		Start Capacitor	216 ufd, 250 VAC
		Run Capacitor	20 ufd, 370 VAC

PERFORMANCE CURVE

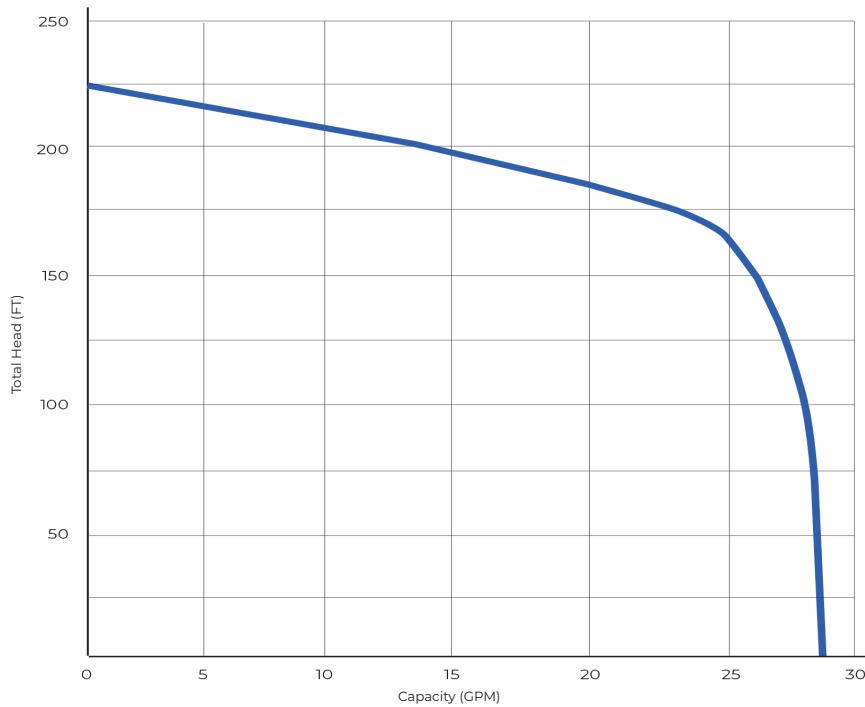

MODEL (HIGH HEAD RADIAL CUTTER)	HP	VOLTS	PHASE	NEC CODE	SERVICE FACTOR	FULL LOAD AMPS	START AMPS	FULL LOAD KW	FULL LOAD KVA
KHHG2H-2001	2	208	1	G	1.0	42.0	148.0	7.43	8.74
KHHG2H-2301	2	230	1	G	1.0	40.0	142.0	7.82	9.20
KHHG2H-2003	2	208	3	H	1.0	29.0	106.0	8.88	10.45
KHHG2H-2303	2	230	3	H	1.0	25.0	88.0	8.47	9.96
KHHG2H-4603	2	460	3	H	1.0	12.5	44.0	8.47	9.96

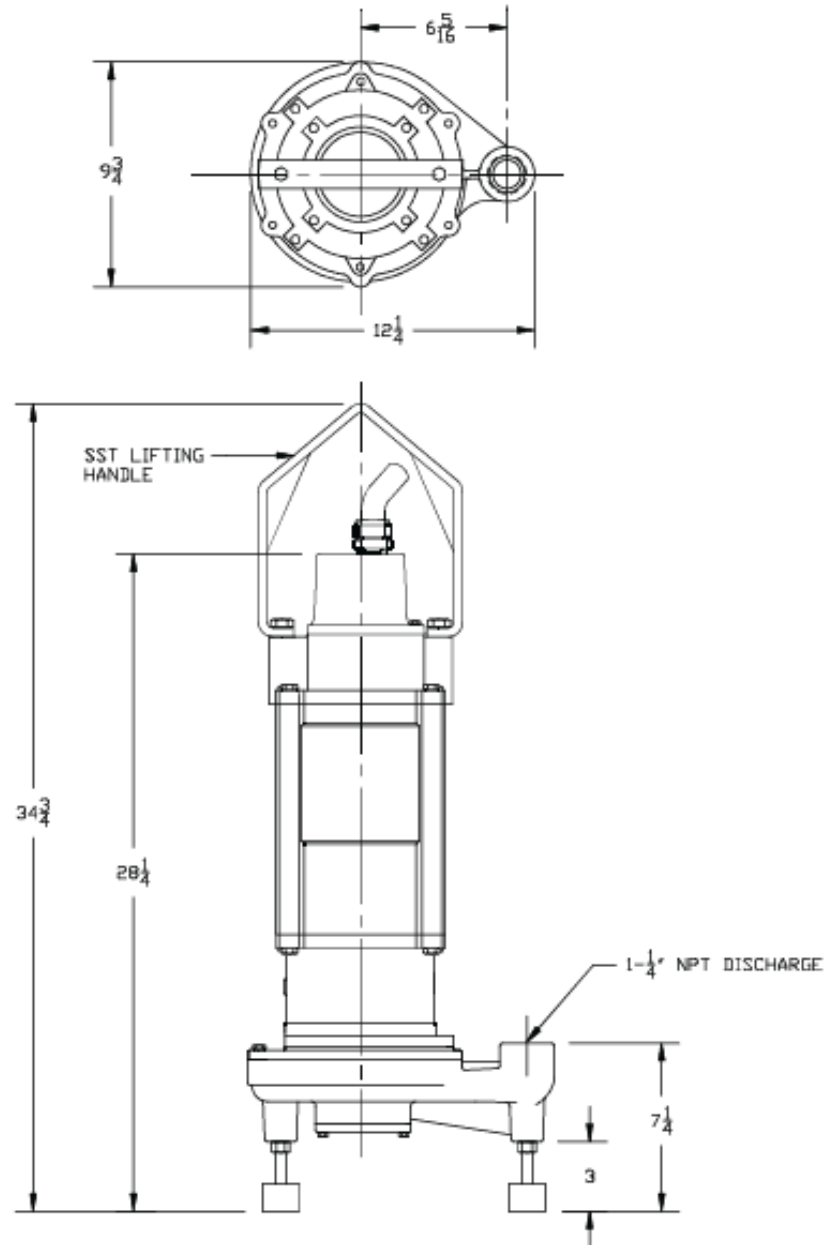



PHYSICAL DATA	
Discharge Size	1-1/4" NPT Vertical
Impeller Type	Balenced, Recessed Vortex
Power/Control Cable Length	40' Standard
Paint	Blue, Powder Coat Paint Finish

MOTOR CONSTRUCTION	
Motor Type	Enclosed Submersible Oil Filled
NEMA Insulation Code	Class N
Service Factor	1.0
Motor Protection	Thermal Sensors Embedded in the Windings
Maximum Stator Temperature	266°F (130°C)
Power Cord (1 Phase)	10-4 SOOW - 600V, 90° C
Power Cord (3 Phase)	10-4 SOOW - 600V, 90° C
Control Cord	18-5 SOOW - 600V, 90° C
Std. Third Party Approval	FM3615

MATERIALS OF CONSTRUCTION	
Cord Entry	Cast Iron, ASTM A48, Class 35
Motor Housing	Cast Iron, ASTM A48, Class 35
Bearing Housing	Cast Iron, ASTM A48, Class 35
Volute	Cast Iron, ASTM A48, Class 35
Impeller	Ductile Iron, ASTM A536, Grade 65-45-12
Shaft	ANSI 400 Stainless Steel
Grinding Impeller	440 SST Hardened 58-60 Rockwell C
Grinding Ring	440 SST Hardened 58-60 Rockwell C
Inboard Mechanical Seal	Silicon Carbide / Silicon Carbide, Viton® Elastomers
Outboard Mechanical Seal	Silicon Carbide / Silicon Carbide, Viton® Elastomers
Fasteners	ANSI 18-8 or 304 Stainless Steel
O-Rings	Fluorocarbon
Upper Bearing	Conrad Style Single Row Deep Groove Ball Bearing 100,000 Hours, L-10
Lower Bearing	Conrad Style Single Row Deep Groove Ball Bearing 100,000 Hours, L-10
Sleeve Bearing	Bronze, Sintered

THERMAL DATA

Maximum Liquid	140° F (60° C)	
Maximum Stator	392° F (200° C)	
Heat Sensor	Open:	275° F (135° C) Max. / 257° F (125° C) Min.
	Closed:	205° F (96° C) Max. / 154° F (68° C) Min.
Oil Flash Point	390° F (199° C)	

ELECTRICAL DATA

RPM	3450			
Electrical Ratings	Heat Sensor	24VDC, 5AMPS	115VAC, 5AMPS	230VAC, 5AMPS
	Seal Fail	300VAC 5mAMPS		
Voltage Tolerance	± 10%			
Internal Start Kit	Start Capacitor = 300 ufd, 250 VAC			
	Run Capacitor = 30 ufd, 370 VAC			



2 HP GRINDER PUMPS

MODEL NO. KHHG2(H)(X)

PUMP MODEL – Pump shall be of the semi-open, centrifugal type, KTG2 (High Head), with an integrally built-in grinder unit and submersible type motor.

OPERATING CONDITIONS – The pump shall have a non-overloading maximum capacity of ___GPM, a maximum total dynamic head of ___ feet, and shall use a motor rated at 2 HP and 3450 RPM. The grinder unit shall be capable of macerating all material in typical domestic and commercial sewage, including reasonable amounts of foreign objects such as sanitary napkins, disposable diapers, thin rubber, sanitary wipes, floor pads, small wood, plastic and the like to fine slurry that will easily pass through the pump and 1-1/4" NPT discharge.

CONSTRUCTION – Major pump components shall be of gray cast iron, ASTM A-48, Class 35, with smooth surfaces devoid of blowholes or other irregularities. All exposed nuts or bolts shall be 304 stainless steel. All metal surfaces coming into contact with the pumpage, other than stainless steel, shall be protected by a factory applied powder coat paint finish to the exterior of the pump..

Sealing design shall incorporate metal-to-metal contact between machined surfaces. Critical mating surfaces where watertight sealing is required shall be machined and fitted with O-rings. Fittings will be the result of controlled compression of rubber O-rings in two planes and O-ring contact of four sides (rabbet joint construction) without the requirement of a specific torque limit. No secondary sealing compounds, elliptical O-rings, grease or other devices shall be used.

PUMP IMPELLER – Pump impeller shall be bronze and threaded onto an AISI 416 stainless steel shaft. The impeller shall be of the semi-open type to provide an unobstructed passage through the volute for the ground solids. Impeller must be dynamically balanced to specification ISO 1940G 6.3 standard.

SLICER GRINDER CONSTRUCTION – Maceration is accomplished by a combination of a rotary slicer and stationary slicer plate. Rotary slicer shall consist of (3) blades which protrude away from the inlet. Rotary slicer shall be bolted to shaft within close tolerance of grinding slicer plate. The stationary slicer plate shall consist of engineered-shaped holes for optimum cutting of debris. A slicer plate shall contain grooved slots to eject pump media away from underneath rotary cutter. Slicer plate shall be fastened with countersunk head screws that are flush with surface of plate. Pumps with protruded or exposed head fasteners shall be considered not equal. Both rotary slicer and slicer plate shall be 440C stainless steel hardened to 58-60 Rockwell C. Both rotary slicer and slicer plate shall be 440C stainless steel hardened to 58-60 Rockwell C. Clearance between rotary slicer and stationary plate shall be controlled by an adjustable design. No shims permitted.

RADIAL CUTTER GRINDER CONSTRUCTION – Provided as a proven cutting method, both grinder impeller and shredding ring shall be of 440 stainless steel hardened to 58-60 Rockwell C. The grinder assembly shall consist of a grinder impeller and shredding ring mounted directly below the volute passage. The grinder impeller is threaded to a stainless steel shaft, locked with a stainless steel screw and washer. The shredding ring shall be secured by a retaining ring which is bolted into the cast iron volute for easy removal. All grinding of solids shall be from the action of the grinder impeller against the shredding ring. There shall be 16,600 cuts / second. Note: Model number to REMOVE "SL" if specifying radial cutter construction Ex. KG2-C (Standard flow pump, non-explosion proof).

SEALS – Type 21, domestic manufactured, dual mechanical seal construction mounted in tandem, shall protect the motor. Standard construction of primary seal shall be silicon / carbide. Standard construction of secondary seal shall be silicon / carbide. The seal face shall be lapped to a flatness of one light band.

Dual electrodes with 330k ohm resistor shall be mounted in the seal chamber to detect water entering the chamber through the lower seal. Water in the chamber shall cause a red light to turn on at the control box. This signal shall not stop the motor, but shall act as a warning only, indicating service is required. Lip seal arrangements shall not be considered equal.

MOTOR – The pump motor construction shall be per NEMA MG-1 1.15 standard and shall be of the submersible type, rated 2 HP, 3450 RPM. The motor shall be for 60 Hz, 208 or 240 volt, single-phase operation. Three-phase operation shall be 208, 230 or 460 volt. Single-phase motors shall be capacitor start, capacitor run type for high starting torque. Start & run capacitors, and electronic relay for operating the motor will be found in the control box. Major motor operating temperature must not exceed Class N ratings.

The stator winding shall be of the open type with Class N insulation. Any other construction shall not be considered equal. The stator shall be pressed into the cast iron motor housing. Winding housing shall be filled with clean, high dielectric oil that lubricates bearings and seals, transferring heat from windings and rotor to the outer cast housing. Maximum skin temperature of motor assembly shall not exceed a T-4 rating per FM3615 standards. Any motor assembly T-code per FM3615 standard that has lesser than a T-4 rating, shall be considered not equal.

Oil Filled Motor ensures industry-low operating temperature. Air-filled motors, which do not have the superior heat dissipating capabilities of oil-filled motors, shall not be considered equal. Single-phase motors shall have automatic reset overload protection attached to the top end of the motor windings to stop the motor if the motor winding temperature reaches 130 degrees C. The high temperature shut-off will cause the pump to cease operation, should a control failure cause the pump to run in a dry wet well. The overload shall automatically reset when the motor cools to a safe operating temperature.

Three-phase motors contain temperature sensors with (2) two wires for attachment to the control panel.

BEARINGS / SHAFT – The motor shall have two heavy-duty ball bearings and one sleeve bearing to support the pump shaft, taking radial and thrust loadings. Bearings shall be designed to an ABEC® System 1 or better. The upper bearing shall be a Conrad type, single row, deep groove ball bearing designed to adequately handle the required radial loads. The lower bearing shall be a single-row angular contact ball bearing designed to adequately compensate for the axial loads and radial forces. Bearings shall be designed to deliver a minimum L-10 bearing life of 100,000 hours when operation is within the limitations of the manufacturer's performance curve. The bearings shall be lubricated in oil and will not require maintenance as described in ANSI/HI 1.4-2010 A.6.

POWER CORD – The motor power cord shall be Type SOOW, UL listed, CSA approved cable. The cable jacket shall be sealed at the motor entrance by means of an agency-approved rubber compression washer and compression nut. An epoxy-filled cord cap seals the outer cable jacket and individual leads to prevent water from entering the motor housing. Compression fittings with quick disconnect molded pins shall not be considered equal. Cord shall withstand a pull strain to meet FM requirements.