



**INSTALLATION AND SERVICE INSTRUCTIONS AND
REPAIR PARTS LIST FOR 2HP “FLAT CAP”
CENTRIFUGAL SUBMERSIBLE GRINDER PUMPS**



“LCG2”

MODELS

Grinder w/ Radial Cutters					
CATALOG NO.	HP	PH	VOLTS	CORD	DISCH
LCG2-2081	2	1	208	12-5	1.25
LCG2-2301	2	1	230	12-5	1.25
LCG2-2401	2	1	240	12-5	1.25

Grinder w/ Axial Slicers					
CATALOG NO.	HP	PH	VOLTS	CORD	DISCH
LCG2-2081SL	2	1	208	12-5	1.25
LCG2-2301SL	2	1	230	12-5	1.25
LCG2-2401SL	2	1	240	12-5	1.25

Read all instructions in this manual before operating pump. Most accidents can be avoided by using COMMON SENSE.

Please Read This Before Installing Or Operating Pump. This information is provided for **SAFETY** and to **PREVENT EQUIPMENT PROBLEMS**. To help recognize this information, observe the following symbols:



IMPORTANT! Warns about hazards that can result in personal injury or indicates factors concerned with assembly, installation, operation, or maintenance which could result in damage to the machine or equipment if ignored.

CAUTION! Warns about hazards that can or will cause minor personal injury or property damage if ignored. Used with symbols below.

WARNING! Warns about hazards that can or will cause serious personal injury, death, or major property damage if ignored. Used with symbols below.



Hazardous fluids can cause fire or explosions, burns or death could result.



Extremely hot - Severe burns can occur on contact.



Biohazard can cause serious personal injury.



Hazardous fluids can Hazardous pressure, eruptions or explosions could cause personal injury or property damage.



Rotating machinery Amputation or severe laceration can result.



Hazardous voltage can shock, burn or cause death.

Only qualified personnel should install, operate and repair pump. Any wiring of pumps should be performed by a qualified electrician.



WARNING! - To reduce risk of electrical shock, pumps and control panels must be properly grounded in accordance with the National Electric Code (NEC) or the Canadian Electrical Code (CEC) and all applicable state, province, local codes and ordinances.

WARNING! - To reduce risk of electrical shock, always disconnect the pump from the power source before handling or servicing. Lock out power and tag.

Prevent large articles of clothing, large amounts of chemicals, other materials or substances such as are uncommon in domestic sewage from entering the system.

During power black-outs, minimize water consumption at the home(s) to prevent sewage from backing up into the house.

Always keep the shut-off valve completely open when system is in operation (unless advised otherwise by the proper authorities). Before removing the pump from the basin, be sure to close the shut-off valve. (This prevents backflow from the pressure sewer.)

Keep the control panel locked or confined to prevent unauthorized access to it.

If the pump is idle for long periods of time, it is advisable to start the pump occasionally by adding water to the basin.



CAUTION! Pumps build up heat and pressure during operation-allow time for pumps to cool before handling or servicing.



WARNING! - DO NOT pump hazardous materials (flammable, caustic, etc.) unless the pump is specifically designed and designated to handle them.

Do not block or restrict discharge hose, as discharge hose may whip under pressure.



WARNING! - DO NOT wear loose clothing that may become entangled in the impeller or other moving parts.

WARNING! - Keep clear of suction and discharge openings. DO NOT insert fingers in pump with power connected.

Make sure lifting handles are securely fastened each time before lifting. Do not operate pump without safety devices in place. Always replace safety devices that have been removed during service or repair.

Do not exceed manufacturers recommendation for maximum performance, as this could cause the motor to overheat.

Secure the pump in its operating position so it can not tip over, fall or slide.

Cable should be protected at all times to avoid punctures, cut, bruises and abrasions - inspect frequently.



Never handle connected power cords with wet hands.

To reduce risk of electrical shock, all wiring and junction connections should be made per the NEC or CEC and applicable state or province and local codes. Requirements may vary depending on usage and location.



Submersible Pumps are not approved for use in swimming pools, recreational water installations, decorative fountains or any installation where human contact with the pumped fluid is common.

Do not remove cord and strain relief. Do not connect conduit to pump.



Products Returned Must Be Cleaned, Sanitized, Or Decontaminated As Necessary Prior To Shipment, To Insure That Employees Will Not Be Exposed To Health Hazards In Handling Said Material. All Applicable Laws And Regulations Shall Apply.

Bronze/brass and bronze/brass fitted pumps may contain lead levels higher than considered safe for potable water systems. Various government agencies have determined that leaded copper alloys should not be used in potable water applications. For non-leaded copper alloy materials of construction, please contact factory.

KEEN PUMP is not responsible for losses, injury or death resulting from a failure to observe these safety precautions, misuse, abuse or misapplication of pumps or equipment.

WARNING!

THE PUMP MUST BE WIRED BY A QUALIFIED ELECTRICIAN, USING AN APPROVED STARTER BOX AND SWITCHING DEVICE.

On 3 phase pumps only, "Motor Protection" must be provided by the installer. All 3 phase pumps must be installed with magnetic starters having 3 leg overload protection in accordance with the NEC (National Electric Code). For duplex installations, both pump motors must have separate overload protection.

Pumps with seal leak detectors must be connected to the proper control circuitry.

DANGER!

HAZARDOUS MOVING PARTS. To reduce risk of injury, disconnect power before servicing. Never put fingers near grinder impeller or in pump inlet when pump cord is connected or pump is operating.

For use with maximum 140 degrees F liquid.

DANGER!

In the initial installation, before sewage is admitted to the basin, there is no danger on entering the basin. **AFTER SEWAGE HAS BEEN IN THE BASIN, THERE IS DANGER.** Sewage water produces methane and hydrogen sulfide gasses, both of which are highly poisonous. A breathing device may be required. Never enter the basin unless cover is open and outside blower is used to force fresh air into the basin. Also the worker in the basin must wear a harness attached to the surface so he can be pulled out in case of asphyxiation. **NEVER WORK ALONE!**

WARNING!

Do not exceed working load limit of lifting chain, cable or rope. Do not use lifting chain, cable or rope where failure could result in loss of life.

Examine all lifting devices, chain, cable or rope for damage before and after each lift. Do not use any lifting devices that are not rated for and designed to lift the weights involved with these pumps. **DO NOT LIFT PUMP BY POWER CORD.**

Do not install or remove pump with person(s) in the basin.

This pump is designed to handle materials which could cause illness or disease through direct exposure. Wear and use protective clothing when working on the pump or piping.

WARNING !

Any wiring to be done on pumps should be done by a qualified electrician.

NEVER operate a pump with a power cord that has frayed or brittle insulation.

NEVER let cords or plugs lay in water.

NEVER handle connected power cords with wet hands.

NEVER be in contact with the liquid being pumped while pump cord is connected to electrical supply.

Only qualified personnel should install, operate or repair pump.

***** **USE AND CARE** *****

DO NOT pump hazardous material not recommended for pump. **NEVER** introduce:

- Explosives
- Flammable Material
- Lubricating Oil and/or Grease
- Chemicals, Solvents, etc.
- Gasoline
- Any Petroleum Product

Regulatory agencies advise that the following items should not be introduced into any sewer:

- Glass
- Metal
- Diapers
- Clothing, socks, rags, etc.
- Plastic objects (toys, utensils, etc.)
- Sanitary napkins or tampons

DO NOT pump without safety devices in place.

For hazardous locations, use pumps listed and classified for such locations.

DO NOT use non-explosion rated pumps in locations considered hazardous in accordance with the National Electric Code, ANSI/NFPA 70-1993.

IMPORTANT!

KEEN PUMP is not responsible for losses, injury or death resulting from failure to observe these safety precautions.

WIRING DIAGRAMS

LCG2-2081/2301/2401 2HP, 208/230/240V, 1 PHASE

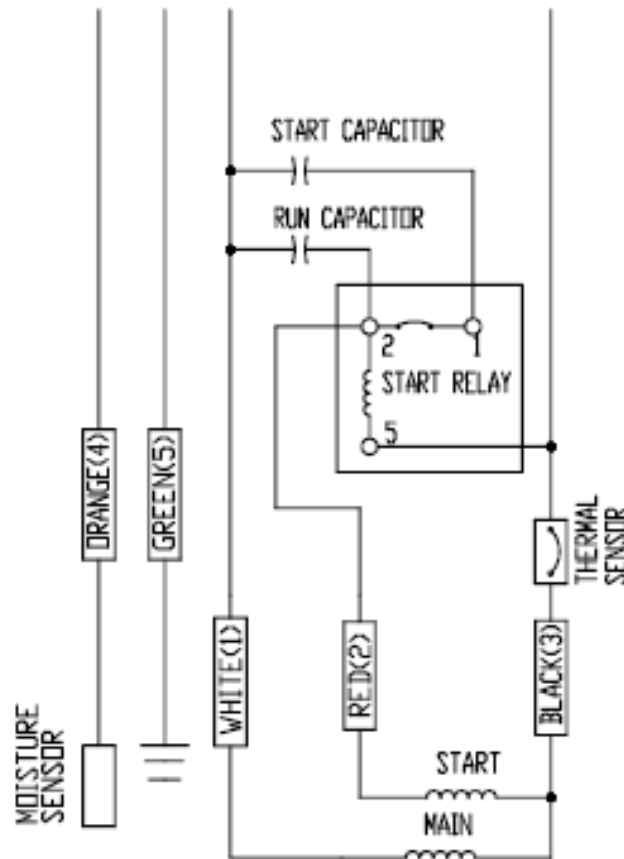

WIRES		VOLT	OHM
WHITE (1)	BLACK (3)	208/230	1.8
WHITE (1)	RED (2)		6.9
BLACK (3)	RED (2)		5.1
WHITE (1)	BLACK (3)	240	1.6
WHITE (1)	RED (2)		6.7
BLACK (3)	RED (2)		5.4

PUMP SPECIFICATIONS

DISCHARGE.....	1-1/4" NPT, Vertical	
LIQUID TEMPERATURE.....	120 degrees F (Continuous) 140 degrees F. (Intermittent)	
MOTOR HOUSING.....	Cast Iron, ASTM A-48, Class 35	
CORD CAP.....	Cast Iron, ASTM A-48, Class 35	
VOLUTE.....	Cast Iron, ASTM A-48, Class 35	
SEAL PLATE.....	Cast Iron, ASTM A-48, Class 35	
IMPELLER.....	Ductile Iron, ASTM A-48, Class 35B 12 vane, Vortex with Pump-out Vanes, Dynamically Balanced	
SHREDDING RING.....	Hardened 440C Stainless Steel 56-60 Rockwell C	
GRINDER IMPELLER.....	Hardened 440C Stainless Steel 56-60 Rockwell C	
RETAINER PLATE (Slicer).....	Hardened 440C Stainless Steel 56-60 Rockwell C	
SLICER IMPELLER (Slicer).....	Hardened 440C Stainless Steel 56-60 Rockwell C	
SHAFT.....	416 Stainless Steel	
SHAFT SEAL.....	Mechanical Main (Motor) Silicon Carbide – Rotating Face Silicon Carbide – Stationary Face Buna-N - Elastomer 300 Series Stainless Steel - Hardware	Secondary (Pump) Silicon Carbide – Rotating Face Silicon Carbide – Stationary Face
BEARING (UPPER).....	Single Row, Ball, Oil Lubricated	
BEARING (LOWER).....	Single Row, Ball, Oil Lubricated	
SLEEVE BEARING.....	Bronze with Oil Groove	
HARDWARE.....	300 Series Stainless Steel	
O-RINGS.....	Buna-N	
CORD.....	12-5 AWG, Type SOOW 30' Length Standard. Other Lengths Available.	
CORD ENTRY.....	Triple Sealed Design Compression Grommet – Outer Jacket Seal Epoxy Potted – Inner Conductor Seal Butt Connector – Inner Wire Strand Wicking Blockage	
MOTOR (SINGLE PHASE).....	2 HP, 3450 RPM, 60 Hz Voltage Options 208 / 230 / 240 Volts Includes Overload Protection in the Motor. Oil Filled, Class N Capacitor Start / Capacitor Run	
	Start Capacitor 216-259 mfd, 250 VAC	Run Capacitor 25 mfd, 370 VAC
	Oil Filled, Class N	
OPTIONAL EQUIPMENT.....	Seal Materials Additional Cable Lengths Impeller Trims	

Installation

USAGE:

The 2 HP grinder pumps are for pumping domestic sewage. One pump can handle the sewage from a maximum of 2 homes.

These pumps are not to be used for pumping commercial or industrial sewage from factories, schools, motels, apartments, etc.

This pump is intended to grind and pump all normal sewage for home use. It will handle reasonable quantities of disposable diapers, sanitary napkins, paper towels, rubber material, wood, cigarette butts, string, plastic and other material not normally found in sewage.

CAUTION!

Pump is not to be disassembled in the field except at certified service stations or at the factory. Warranty is void if pump is taken apart for any reason other than to replace grinder impeller and grinder ring, which is covered in these instructions.

PACKAGING

Each pump is packaged with 30 feet of power cord in a carton that is marked with the Model Number. Longer cords are available – consult factory.

INSPECTING PUMP

Before making any piping or electrical connections, check pump for any shipping damage. Turn grinder impeller to be sure it is free. **DO NOT TURN IMPELLER WITH FINGERS AS EDGES ARE SHARP.** Use allen wrench in the impeller screw to turn the impeller.

CAUTION!

No persons should be in the basin when pump is lowered into position! **DO NOT** lift pump in a manner where failure could result in loss of life.

After pump is installed in basin, **NEVER WORK ON MOTOR OR GRINDER UNIT WITHOUT DISCONNECTING MOTOR LEAD WIRES FROM CONTROL PANEL. DO NOT RELY UPON OPENING THE CIRCUIT BREAKER ONLY!**

ELECTRICAL:

MOTOR OVERLOAD PROTECTION

Single phase motors are provided with an on-winding thermal overload switch. If motor overloads or overheats for any reason, the switch opens, stopping motor. As soon as the motor cools to normal temperature, the switch automatically closes and restarts motor.

MOISTURE DETECTION

All 2 HP, dual seal grinder pumps with external start kit or 3-phase, contain an electrode for detecting water within the unit. The electrode is housed within the secondary seal chamber, isolated from the motor chamber. If the electrode detects water within the oil-filled housing, it will close the circuit to the red alarm light in the control panel, indicating the pump must be serviced before the upper seal fails.

MOTOR POWER CORDS

Pump models with seal leak detector, single phase use a 12AWG-5C cord. The three power conductors are **BLACK**, **WHITE** and **RED**. The **ORANGE** conductor connects to the seal leak probe and **GREEN** conductor connects to the ground screw inside the cord cap.

For single phase,
BLACK is “Common”
WHITE is “Run”
RED is “Start”.

IMPORTANT!

Ground wires must be connected in the control box to grounding bar, which is connected to a good suitable ground.
MOTOR IS NOT SAFE UNLESS PROPERLY GROUNDED.

IMPELLER ROTATION: When looking at the bottom of the pump and through the inlet of the volute, rotation of the impeller is **COUNTER-CLOCKWISE.**

TROUBLESHOOTING

The troubles listed below are potential problems involving the pump. Other troubles can occur from faulty control box operation. Consult control box instructions for troubleshooting list involving the control box.

PROBLEM

PROBABLE CAUSE

Pump will not run.

Tripped breaker, blown fuse, poor electrical connection, interruption of power, improper power supply.
Float switch defective or restricted.
On single phase pumps, electronic start switch or capacitors blown.
Overload in motor tripped.
Solid material lodged in pump inlet.

Pump runs, but does not pump liquid from basin.

Pump impeller may be air locked. Start and stop pump several times to purge air. Check to ensure vent hole in volute is open and clean.
Lower "OFF" float may be set too low, allowing air into pump.
Pump inlet or valves in discharge pipe may be clogged.
Discharge valve may be closed.

Pump hums, but does not run.

Incorrect voltage.
Pump inlet plugged.
Cutter jammed or loose on shaft, worn or damaged.

Pump delivers low volume of water.

Low voltage.
On three phase pumps, motor running backwards.
Discharge restricted.
Check valve stuck closed or installed backwards.
Pump motor damaged / worn.
Pump may be air locked.
Cutter loose or jammed on shaft, worn or damaged.

Pump is noisy.

Grinder impeller may be rubbing against grinder ring due to misalignment, bent shaft or object stuck in impeller.
Grinder assembly may be partially clogged.
Pump cavitation due to low discharge pressure.

Pump cycles frequently.

Check valve stuck closed or installed backwards.
Ground water entering basin.
Fixtures are leaking.

Pump will not turn off.

Float switch defective or movement restricted.
H-O-A switch in panel is in "HAND" position.
Pump may be air locked.
Excessive inflow / pump not sized for the application.

Grease and solids accumulated in basin and will not pump out.

Pump "ON" switch may be set too high.
Debris may have accumulated around lower float weight causing pump to turn off too soon. Clean debris away from weight and cord.

Red light illuminated at control box.

Moisture detection in double seal pumps indicating service is required.
Lower seal has failed. Secondary seal still functioning.

Circuit breaker trips.

Electrical short to ground.
Check troubleshooting in control panel before pulling pump.
Check all electrical cords for damage.
Pull pump and take resistance readings of motor to determine if problem is in the pump or control box.

REPLACING GRINDER IMPELLER AND SHREDDING RING “RADIAL CUTTERS”

Note: This is the only disassembly operation permitted in the field.
All other repairs must be performed at an authorized service center or the factory.

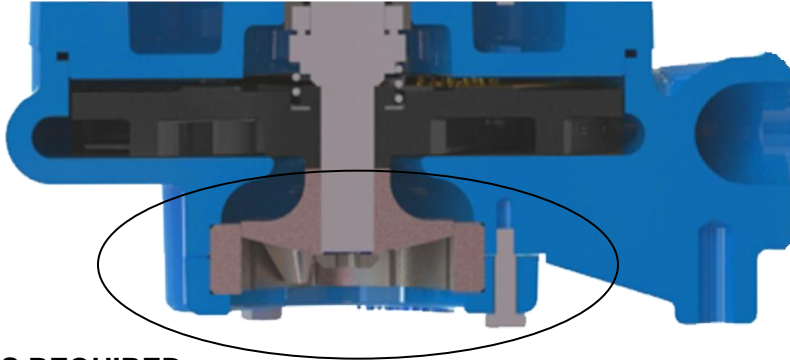

STANDARD TOOLS REQUIRED:

- Standard socket wrench set.
- Standard set of open end wrenches.
- Hammer.
- Vise grip pliers.
- Allen head socket set.
- Screwdrivers.
- Wire brush.

CAUTION – Disconnect all power and control wires to motor at the control panel before starting the disassembly operations. Do not rely upon opening the circuit breaker only.

IMPORTANT – Pump should be sanitized with bleach before starting work.

Pump should be thoroughly cleaned of trash and deposits before starting disassembly operations.

Wear protective gloves and clothing.

Always use a rag on the impeller when turning to prevent cutting hands on the sharp edges of the shredding ring.

DISASSEMBLY OF SHREDDING RING AND GRINDER IMPELLER

1. Hold the grinder impeller by prying against the impeller cutting bar and remove the allen head cap screw from the end of the shaft.
2. Use a large screwdriver in the slot end of the shaft and tap (counterclockwise) on one of the large cutter vanes with a hammer. Tap in a counterclockwise direction (thread is right hand).
3. If the impeller removes easily, clean and replace if worn.
4. Make sure the pump impeller has not loosened when the grinder impeller was removed. This can be checked on reassembly of grinder impeller and shredding ring. The tips of the impeller cutter vanes should extend 1/8” below the bottom of the shredding ring. If the distance is greater, the pump impeller has loosened. If the distance is less, the shredding ring is not properly seated.
5. After the volute case has been removed, insert screwdriver in slot end of shaft and tap hammer against the outer vane of the ductile iron pump impeller (clockwise) to ensure it is threaded tight against shoulder on shaft.
6. Use large screwdriver to tap stainless steel cutter ring from cast iron volute.
7. Clean all threads with a wire brush and file smooth any nicked threads. Use NEVER-SEEZE or other graphite compound on threads before replacing grinder impeller.

8. Make sure allen head cap screw in bottom of pump shaft is tight. Make sure the impeller turns freely by hand after reassembly. Some drag will be present due to the shaft seals. There should not be any binding or tight spots when turning the grinder impeller.

REPLACING IMPELLER AND RETAINER PLATE “AXIAL SLICERS”

Note: This is the only disassembly operation permitted in the field.
All other repairs must be performed at an authorized service center or the factory.

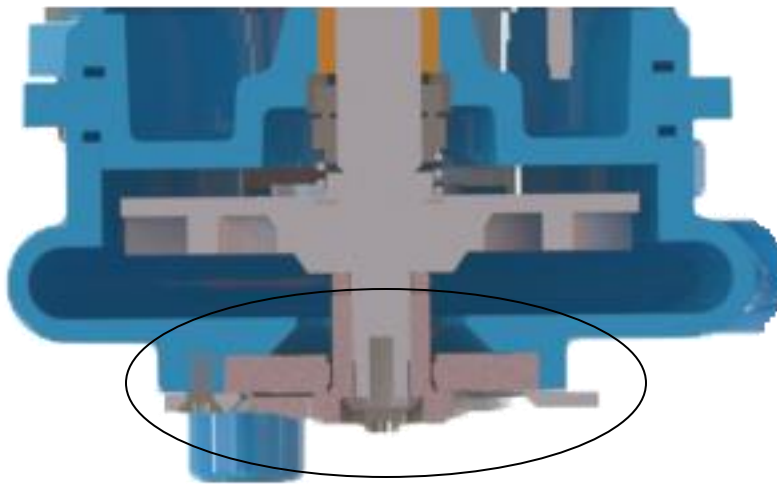

STANDARD TOOLS REQUIRED:

- Standard socket wrench set.
- Ball-peen Hammer.
- Feeler Gauges (minimum range .008-.012 inches)
- Vise grip pliers.
- Allen head socket set.
- Screwdrivers.
- Wire brush.

CAUTION – Disconnect all power and control wires to motor at the control panel before starting the disassembly operations. Do not rely upon opening the circuit breaker only.

IMPORTANT – Pump should be sanitized with bleach before starting work.

Pump should be thoroughly cleaned of trash and deposits before starting disassembly operations.

Wear protective gloves and clothing.

Always use a rag on the impeller when turning to prevent cutting hands on the sharp edges of the impeller and slicer plate.

DISASSEMBLY OR REPLACING OF SLICER PLATE AND SLICER IMPELLER

1. Remove Slicer retainer (3 bolts).
2. Use a ball-peen hammer to tap onto (3 blade) rotary slicer impeller. Tap in a counterclockwise direction (thread is right hand).
3. Remove "disk-shaped" slicer plate. May have to pry with screwdriver.
4. Once slicer plate is removed, shims will be visible on threaded shaft.
5. Slicer parts can now be cleaned and reassembled or replaced.
6. If discarding all shims, you must use new shims from shim kit.
7. Place (Qty:2) .01 inch shims onto threaded shaft, making certain to align keyway of stock with shaft.
8. Place new or cleaned slicer plate onto threaded shaft, making sure shims stay in place along keyway.
9. Place new or cleaned rotary (3 blade) slicer impeller onto threaded shaft, turning (Clockwise).
10. Rotate onto shaft with hands until snug. Use ball-peen hammer to lock onto shaft.
11. **IMPORTANT: USING FEELER GAUGES, CHECK DISTANCE BETWEEN SLICER PLATE AND SLICER IMPELLER. DISTANCE TOLERANCE (.008-.012 INCHES).**
12. If tolerance is satisfactory, go to step 13. If tolerance is beyond or under range, go back to step 7.
13. Place new or cleaned slicer retainer onto volute bottom.
14. Make sure the impeller turns freely by hand after reassembly. Some drag will be present due to the shaft seals. There should not be any binding or tight spots when turning the slicer impeller.

REPAIR PARTS LIST

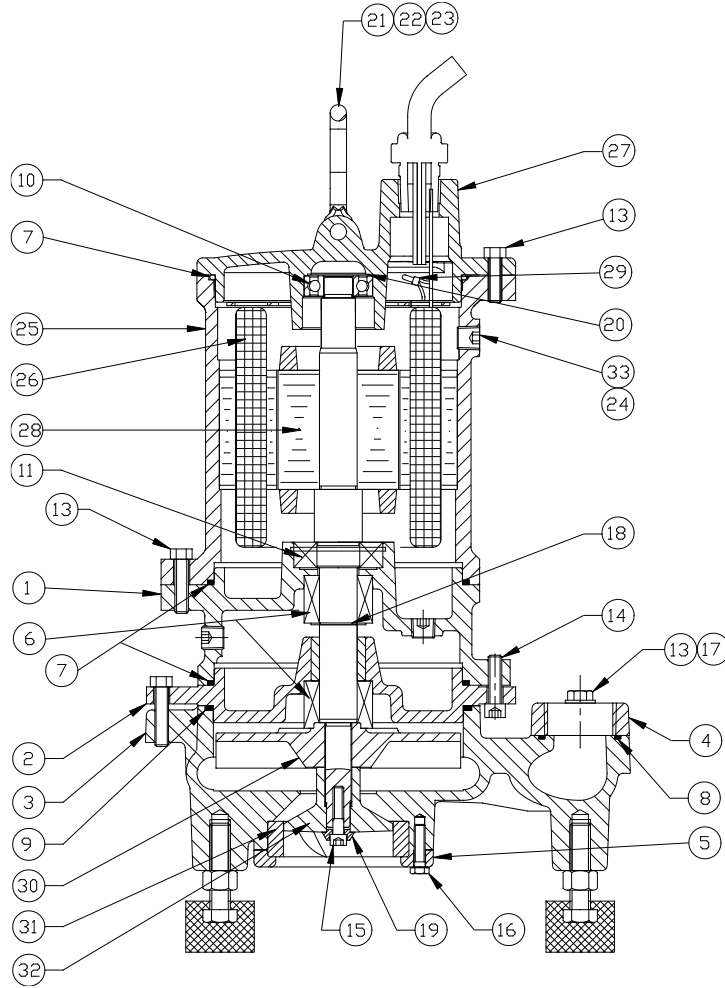

“RADIAL CUTTER”

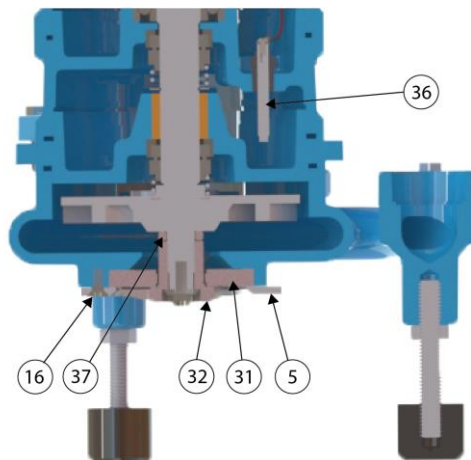

“AXIAL SLICER”

Pump Model Numbers w/ Radial Cutters		LCG2-2081/2301/2401	
REF. #	DESCRIPTION	QTY.	PART NUMBER
Castings			
1	Housing, Lower Bearing, Cast Iron	1	KGA2011-2-01
2	Seal Plate, Lower, Cast Iron	1	KGA2014-5-01
3	Volute Case, Cast Iron	1	KG2015-2-100
4	Adapter, Discharge, 1-1/4" NPT, Cast iron	1	KG2026
5	Retainer, Shredding ring, Cast Iron	1	K0446-2-01
5	Retainer, Slicer Plate, SST	1	K0453-1-01
6	Seal, Shaft, Lower and Upper, Sil. Carbide, Type 21	2	KG2172
7	O-Ring, Buna-N, Motor, Cord Cap, Brg. Hsg., 5-7/8 OD	4	KG2010
8	O-Ring, 2hp volute adapter, Buna-N, 1-7/8 OD	1	KG2025
9	Square ring, Buna N, K(H)G Volute, 6.012 OD	1	KG2016
10	Bearing, Ball, Upper Ball, 1.575OD	1	KG2003
11	Bearing, Ball, 2hp Lower, 2.047OD	1	KG2009
13	Screw, Cap, 5/16-18UNC x 1-1/4" LG, SST	14	CS5/16X1-1/4SS
14	Screw, Allen HD, 5/16-18UNC x 1" LG, SST	4	SCS5/16X1SS
15	Screw, Allen HD, 1/4-20UNC x 5/8" LG, SST	1	SCS1/4X5/8SS
16	Screw, Cap, 1/4-20UNC x 1" LG, SST	3	CS1/4X1SS
17	Washer, Flat 5/16", 300 series SST	2	WASH5/16SS
18	Retaining Ring, Black- Finish Steel, External	1	KG2089
19	Disc Retainer Ring, 2hp grinder impeller, 304 SST	1	KG2024
20	Disc Spring, wave, steel	1	KG2118-1
21	Handle, Lifting, SST	1	K0739-3-01
22	Pin, Handle Clevis, 3/8" dia.	1	K0740-1-01
23	Pin, Hitch clip, sst	1	K0741-1-01
24	Oil, Dielectric	56 oz	K0737-1-01
25	Assembly, Housing & Stator 208 & 230 Volt, 1 ph	1	KGA2097
25	Assembly, Housing & Stator 240 Volt, 1 ph	1	KGA2097-5-100
	Housing, motor, Cast iron	1	KGA2006-2-01
26	Stator 208 & 230 Volt, 1 ph	1	KG2007*
26	Stator 240 Volt, 1 ph	1	K0477-1*
27	Assy, Flat Cord Cap, 30' LG, 12/5, 1 phase	1	K0700-12530
28	Rotor and shaft assembly 2 hp, 1 phase , Hazloc	1	KGX2096*
29	Pre-insulated Crimp Wire Connector 6LU60	4	WC2-14
30	Impeller, Cast Iron, 5.35 dia., Standard flow	1	KG2018-2-01
30	Impeller, Slicer	1	K0454-2-100
31	Ring, Grinder, SST	1	KG2149-0-01
32	Impeller, Grinding, SST	1	KG2019-2-01
31	Plate Slicer	1	K0452-2-01
32	Impeller, Slicer	1	K0454-2-100
33	Plug, 1/4 NPT pipe, SST	3	PLUG1/4
34	Plate, Slicer	1	K0452-2-01
34	Nameplate, Keen Submersible Pump (Not pictured)	1	KNP0003
35	Screw, Drive #4-7 UNC X 1/4' LG (Not pictured)	6	DS4x1/4SS
36	Sensor, Moisture	1	K0141-5-04

*After Jan 19, Add F-Suffix



Limited Warranty

During the time periods and subject to the conditions hereinafter set forth, Keen Pump will repair or replace to the original user or consumer, any portion of your new Keen product which proves defective due to defective materials or workmanship of Keen Pump. Contact your closest authorized Keen Pump representative or distributor for warranty service. At all times, Keen Pump shall have and possess the sole right and option to determine whether to repair or replace defective equipment, parts or components. Damage caused by acts of GOD or conditions beyond the control of Keen Pump is not covered by this warranty.

WARRANTY PERIOD:

36 months from date of manufacture.

Start-up reports are required to support warranty claims. Warranty effective only if Keen Pump supplied or authorized control panels are used. Single phase pumps must utilize Keen Pump supplied start components.

THIS WARRANTY WILL NOT APPLY:

- (1) To defects or malfunctions resulting from failure to properly install, operate or maintained the product in accordance with printed instructions provided.
- (2) To failures resulting from abuse, accident or negligence.
- (3) To normal maintenance services and the parts used in conjunction with such service.
- (4) To products which are not installed in accordance with applicable local codes, ordinances and good trade practices.
- (5) The product is used for purposes other than for what is was designed and manufactured.
- (6) If 3 phase motors are installed on a single phase power supply using a phase converter or if 3 phase power is supplied by only two transformers, making an open Delta system.

WARRANTY EXCLUSIONS:

Keen Pump specifically disclaims the implied warranties of merchantability and fitness for a particular purpose after the termination of the warranty period set forth herein. No warranties or representations at any time made by any representatives of Keen Pump shall vary or expand the provision hereof.

LIABILITY LIMITATION:

In no event shall Keen Pump be liable or responsible for consequential, incidental or special damages resulting from or related in any manner to any Keen Pump product or parts thereof. Personal injury and/or property damage may result from improper installation. Keen Pump disclaims all liability, including liability under this warranty, for improper installation. Keen Pump recommends following the instructions in the installation manual. When in doubt, consult a professional. Some states do not allow the exclusion or limitation of incidental or consequential damages, so the above limitation or exclusion may not apply to you.

LABOR, ETC., COSTS:

Keen Pump shall in no event be responsible or liable for the cost of field labor or other charges incurred by any customer in removing and/or reaffixing any Keen Pump product, part or component thereof or any temporary pumping of other equipment.

RETURNED OR REPLACED COMPONENTS:

Any item to be replaced under this Warranty must be returned to Keen Pump, or such other place as Keen Pump may designate, freight prepaid.

This warranty gives you specific legal rights and other rights which may vary from state to state.

In the absence of suitable proof of this purchase date, the effective date of this warranty will be based upon the date of manufacture. Example: 1501 = Year-Month = 2015, January

P/N O&M-LCG2

Keen Pump Grinder Recommended Limits of Application

Model	HP	Max. Flow	Max. Head	Simplex		Duplex	
				Homes (EDUs)	Gallons/Day	Homes (EDUs)	Gallons/Day
KPCG	1	15	*	2	800	4	1600
LCG2	2	59	116				
KG2	2	43	106	4	1600	8	3200
KHG2	2	20	130	3	1200	6	2400
KHHG2	2	30	160	3	1200	6	2400
KHHG2H	2	28	225	3	1200	6	2400
KG3	3	183	65	12	4800	25	10000
KG5	5	190	87	25	10000	50	20000
KHG3	3	100	105	6	2400	12	4800
KHG5	5	100	140	8	4000	16	8000
KHG7	7.5	100	170	10	4800	20	10000
KG10	10	185	160	25	10000	50	20000

* KPCG 1hp Progressive Cavity pump Max Head based on Minimum Flow requirements
 Minimum Flow = 6 GPM
 Maximum Head = 225 TDH

