



INSTALLATION AND SERVICE INSTRUCTIONS AND REPAIR PARTS LIST FOR KTG2 SUBMERSIBLE GRINDER PUMPS



“KTG2”

P/N O&M-KTG2
Effective March 2025

Read all instructions in this manual before operating pump. Most accidents can be avoided by using COMMON SENSE.

Please Read This Before Installing Or Operating Pump. This information is provided for **SAFETY** and to **PREVENT EQUIPMENT PROBLEMS**. To help recognize this information, observe the following symbols:



IMPORTANT! Warns about hazards that can result in personal injury or indicates factors concerned with assembly, installation, operation, or maintenance which could result in damage to the machine or equipment if ignored.

CAUTION! Warns about hazards that can or will cause minor personal injury or property damage if ignored. Used with symbols below.

WARNING! Warns about hazards that can or will cause serious personal injury, death, or major property damage if ignored. Used with symbols below.



Hazardous fluids can cause fire or explosions, burns or death could result.



Extremely hot - Severe burns can occur on contact.



Biohazard can cause serious personal injury.



Hazardous fluids can cause hazardous pressure, eruptions or explosions could cause personal injury or property damage.



Rotating machinery Amputation or severe laceration can result.



Hazardous voltage can shock, burn or cause death.

Only qualified personnel should install, operate and repair pump. Any wiring of pumps should be performed by a qualified electrician.



WARNING! - To reduce risk of electrical shock, pumps and control panels must be properly grounded in accordance with the National Electric Code (NEC) or the Canadian Electrical Code (CEC) and all applicable state, province, local codes and ordinances.

WARNING! - To reduce risk of electrical shock, always disconnect the pump from the power source before handling or servicing. Lock out power and tag.

Prevent large articles of clothing, large amounts of chemicals, other materials or substances such as are uncommon in domestic sewage from entering the system.

During power black-outs, minimize water consumption at the home(s) to prevent sewage from backing up into the house.

Always keep the shut-off valve completely open when system is in operation (unless advised otherwise by the proper authorities). Before removing the pump from the basin, be sure to close the shut-off valve. (This prevents backflow from the pressure sewer.)

Keep the control panel locked or confined to prevent unauthorized access to it.

If the pump is idle for long periods of time, it is advisable to start the pump occasionally by adding water to the basin.



CAUTION! Pumps build up heat and pressure during operation-allow time for pumps to cool before handling or servicing.



WARNING! - DO NOT pump hazardous materials (flammable, caustic, etc.) unless the pump is specifically designed and designated to handle them.

Do not block or restrict discharge hose, as discharge hose may whip under pressure.



WARNING! - DO NOT wear loose clothing that may become entangled in the impeller or other moving parts.

WARNING! - Keep clear of suction and discharge openings. DO NOT insert fingers in pump with power connected.

Make sure lifting handles are securely fastened each time before lifting. Do not operate pump without safety devices in place. Always replace safety devices that have been removed during service or repair.

Do not exceed manufacturers recommendation for maximum performance, as this could cause the motor to overheat.

Secure the pump in its operating position so it can not tip over, fall or slide.

Cable should be protected at all times to avoid punctures, cut, bruises and abrasions - inspect frequently.



Never handle connected power cords with wet hands.

To reduce risk of electrical shock, all wiring and junction connections should be made per the NEC or CEC and applicable state or province and local codes. Requirements may vary depending on usage and location.



Submersible Pumps are not approved for use in swimming pools, recreational water installations, decorative fountains or any installation where human contact with the pumped fluid is common.

Do not remove cord and strain relief. Do not connect conduit to pump.



Products Returned Must Be Cleaned, Sanitized, Or Decontaminated As Necessary Prior To Shipment, To Insure That Employees Will Not Be Exposed To Health Hazards In Handling Said Material. All Applicable Laws And Regulations Shall Apply.



Bronze/brass and bronze/brass fitted pumps may contain lead levels higher than considered safe for potable water systems. Various government agencies have determined that leaded copper alloys should not be used in potable water applications. For non-leaded copper alloy materials of construction, please contact factory.

KEEN PUMP is not responsible for losses, injury or death resulting from a failure to observe these safety precautions, misuse, abuse or misapplication of pumps or equipment.

WARNING !

Any wiring to be done on pumps should be done by a qualified electrician.

NEVER operate a pump with a power cord that has frayed or brittle insulation.

NEVER let cords or plugs lay in water.

NEVER handle connected power cords with wet hands.

NEVER be in contact with the liquid being pumped while pump cord is connected to electrical supply.

Only qualified personnel should install, operate or repair pump.

***** **USE AND CARE** *****

DO NOT pump hazardous material not recommended for pump. NEVER introduce:

- Explosives
- Flammable Material
- Lubricating Oil and/or Grease
- Chemicals, Solvents, etc.
- Gasoline
- Any Petroleum Product

Regulatory agencies advise that the following items should not be introduced into any sewer:

- Glass
- Metal
- Diapers
- Clothing, socks, rags, etc.
- Plastic objects (toys, utensils, etc.)
- Sanitary napkins or tampons

DO NOT pump without safety devices in place.

For hazardous locations, use pumps listed and classified for such locations.

DO NOT use non-explosion rated pumps in locations considered hazardous in accordance with the National Electric Code, ANSI/NFPA 70-1993.

IMPORTANT!

KEEN PUMP is not responsible for losses, injury or death resulting from failure to observe these safety precautions.

WARNING!

THE PUMP MUST BE WIRED BY A QUALIFIED ELECTRICIAN, USING AN APPROVED STARTER BOX AND SWITCHING DEVICE.

On 3 phase pumps only, "Motor Protection" must be provided by the installer. All 3 phase pumps must be installed with magnetic starters having 3 leg overload protection in accordance with the NEC (National Electric Code). For duplex installations, both pump motors must have separate overload protection.

Pumps with seal leak detectors must be connected to the proper control circuitry.

DANGER!

HAZARDOUS MOVING PARTS. To reduce risk of injury, disconnect power before servicing. Never put fingers near grinder impeller or in pump inlet when pump cord is connected or pump is operating.

For use with maximum 140 degrees F liquid.

DANGER!

In the initial installation, before sewage is admitted to the basin, there is no danger on entering the basin. AFTER SEWAGE HAS BEEN IN THE BASIN, THERE IS DANGER. Sewage water produces methane and hydrogen sulfide gasses, both of which are highly poisonous. A breathing device may be required. Never enter the basin unless cover is open and outside blower is used to force fresh air into the basin. Also the worker in the basin must wear a harness attached to the surface so he can be pulled out in case of asphyxiation. NEVER WORK ALONE!

WARNING!

Do not exceed working load limit of lifting chain, cable or rope. Do not use lifting chain, cable or rope where failure could result in loss of life.

Examine all lifting devices, chain, cable or rope for damage before and after each lift. Do not use any lifting devices that are not rated for and designed to lift the weights involved with these pumps. DO NOT LIFT PUMP BY POWER CORD.

Do not install or remove pump with person(s) in the basin.

This pump is designed to handle materials which could cause illness or disease through direct exposure. Wear and use protective clothing when working on the pump or piping.

WIRING DIAGRAMS

KTG2-2401C 2HP, 240 Volt, 1-Phase

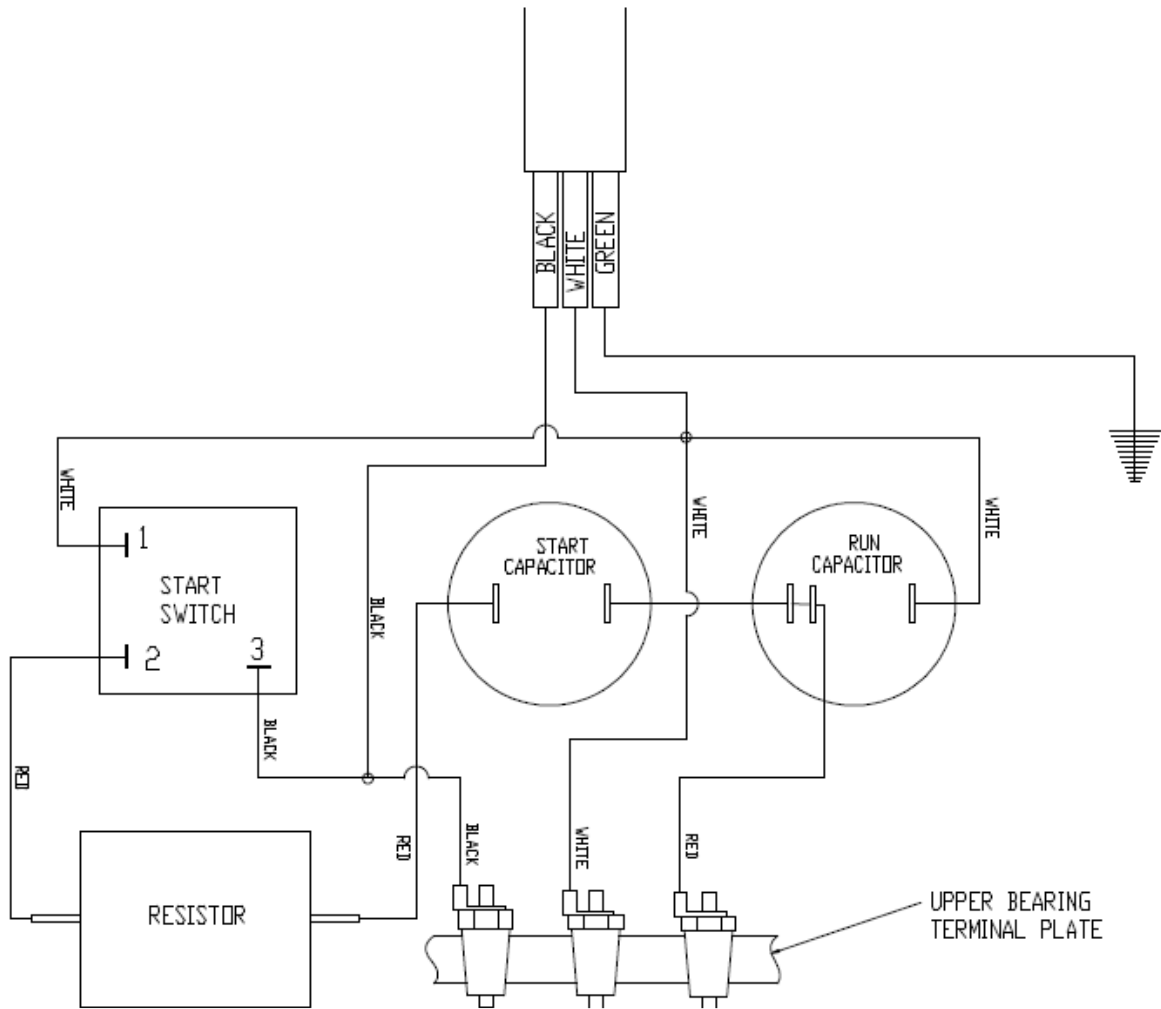

WIRE	240V
BLACK TO WHITE	1.6

PUMP SPECIFICATIONS

DISCHARGE.....	1-1/4" NPT, Vertical	
LIQUID TEMPERATURE.....	120 degrees F (Continuous) 140 degrees F. (Intermittent)	
MOTOR HOUSING.....	Cast Iron, ASTM A-48, Class 35	
CORD CAP.....	Cast Iron, ASTM A-48, Class 35	
VOLUTE.....	Cast Iron, ASTM A-48, Class 35	
SEAL PLATE.....	Cast Iron, ASTM A-48, Class 35	
IMPELLER.....	Ductile Iron, ASTM A-48, Class 35B 12 vane, Vortex with Pump-out Vanes, Dynamically Balanced	
SHREDDING RING.....	Hardened 440C Stainless Steel 56-60 Rockwell C	
GRINDER IMPELLER.....	Hardened 440C Stainless Steel 56-60 Rockwell C	
SHAFT.....	416 Stainless Steel	
SHAFT SEAL.....	Mechanical	Main (Motor) Silicon Carbide – Rotating Face Silicon Carbide – Stationary Face Buna-N - Elastomer 300 Series Stainless Steel - Hardware
BEARING (UPPER).....	Single Row, Ball, Oil Lubricated	
BEARING (LOWER).....	Single Row, Ball, Oil Lubricated	
HARDWARE.....	300 Series Stainless Steel	
O-RINGS.....	Buna-N	
CORD.....	12-3 AWG, Type SOOW ("C" Model) 30' Length Standard. Other Lengths Available.	
CORD ENTRY.....	Triple Sealed Design Compression Grommet – Outer Jacket Seal Epoxy Potted – Inner Conductor Seal Butt Connector – Inner Wire Strand Wicking Blockage	
MOTOR (SINGLE PHASE).....	2 HP, 3450 RPM, 60 Hz Voltage Options 240 Volts Includes Overload Protection in the Motor. Oil Filled, Class N Capacitor Start / Capacitor Run	
KTG2-2401C.....	Start Capacitor 216 mfd, 250 VAC	Run Capacitor 25 mfd, 370 VAC
MOTOR (THREE PHASE).....	2 HP, 3450 RPM, 60 Hz Tri-voltage, 208 / 230 / 460 volts On-Winding temperature sensor, requires temperature sensor circuitry in control panel Oil Filled, Class N	
OPTIONAL EQUIPMENT.....	Seal Materials Additional Cable Lengths Impeller Trims	

Installation

USAGE:

The 2 HP grinder pumps are for pumping domestic sewage. One pump can handle the sewage from a maximum of 2 homes.

These pumps are not to be used for pumping commercial or industrial sewage from factories, schools, motels, apartments, etc.

This pump is intended to grind and pump all normal sewage for home use. It will handle reasonable quantities of disposable diapers, sanitary napkins, paper towels, rubber material, wood, cigarette butts, string, plastic and other material not normally found in sewage.

CAUTION!

Pump is not to be disassembled in the field except at certified service stations or at the factory. Warranty is void if pump is taken apart for any reason other than to replace grinder impeller and grinder ring, which is covered in these instructions.

PACKAGING

Each pump is packaged with 30 feet of power cord in a carton that is marked with the Model Number. Longer cords are available – consult factory.

INSPECTING PUMP

Before making any piping or electrical connections, check pump for any shipping damage. Turn grinder impeller to be sure it is free. **DO NOT TURN IMPELLER WITH FINGERS AS EDGES ARE SHARP.** Use allen wrench in the impeller screw to turn the impeller.

CAUTION!

No persons should be in the basin when pump is lowered into position! **DO NOT** lift pump in a manner where failure could result in loss of life.

After pump is installed in basin, **NEVER WORK ON MOTOR OR GRINDER UNIT WITHOUT DISCONNECTING MOTOR LEAD WIRES FROM CONTROL PANEL. DO NOT RELY UPON OPENING THE CIRCUIT BREAKER ONLY!**

ELECTRICAL:

MOTOR OVERLOAD PROTECTION

Single phase motors are provided with an on-winding thermal overload switch. If motor overloads or overheats for any reason, the switch opens, stopping motor. As soon as the motor cools to normal temperature, the switch automatically closes and restarts motor.

IMPORTANT!

Ground wires must be connected in the control box to grounding bar, which is connected to a good suitable ground. **MOTOR IS NOT SAFE UNLESS PROPERLY GROUNDED.**

IMPELLER ROTATION: When looking at the bottom of the pump and through the inlet of the volute, rotation of the impeller is **COUNTER-CLOCKWISE.**

TROUBLESHOOTING

The troubles listed below are potential problems involving the pump. Other troubles can occur from faulty control box operation. Consult control box instructions for troubleshooting list involving the control box.

PROBLEM

PROBABLE CAUSE

Pump will not run.

Tripped breaker, blown fuse, poor electrical connection, interruption of power, improper power supply.
Float switch defective or restricted.
On single phase pumps, electronic start switch or capacitors blown.
Overload in motor tripped.
Solid material lodged in pump inlet.

Pump runs, but does not pump liquid from basin.

Pump impeller may be air locked. Start and stop pump several times to purge air.
Check to ensure vent hole in volute is open and clean.
Lower "OFF" float may be set too low, allowing air into pump.
Pump inlet or valves in discharge pipe may be clogged.
Discharge valve may be closed.

Pump hums, but does not run.

Incorrect voltage.
Pump inlet plugged.
Cutter jammed or loose on shaft, worn or damaged.

Pump delivers low volume of water.

Low voltage.
On three phase pumps, motor running backwards.
Discharge restricted.
Check valve stuck closed or installed backwards.
Pump motor damaged / worn.
Pump may be air locked.
Cutter loose or jammed on shaft, worn or damaged.

Pump is noisy.

Grinder impeller may be rubbing against grinder ring due to misalignment, bent shaft or object stuck in impeller.
Grinder assembly may be partially clogged.
Pump cavitation due to low discharge pressure.

Pump cycles frequently.

Check valve stuck closed or installed backwards.
Ground water entering basin.
Fixtures are leaking.

Pump will not turn off.

Float switch defective or movement restricted.
H-O-A switch in panel is in "HAND" position.
Pump may be air locked.
Excessive inflow / pump not sized for the application.

Grease and solids accumulated in basin and will not pump out.

Pump "ON" switch may be set too high.
Debris may have accumulated around lower float weight causing pump to turn off too soon. Clean debris away from weight and cord.

Red light illuminated at control box.

Moisture detection in double seal pumps indicating service is required.
Lower seal has failed. Secondary seal still functioning.

Circuit breaker trips.

Electrical short to ground.
Check troubleshooting in control panel before pulling pump.
Check all electrical cords for damage.
Pull pump and take resistance readings of motor to determine if problem is in the pump or control box.

REPLACING GRINDER IMPELLER AND SHREDDING RING “RADIAL CUTTERS”

**Note: This is the only disassembly operation permitted in the field.
All other repairs must be performed at an authorized service center or the factory.**

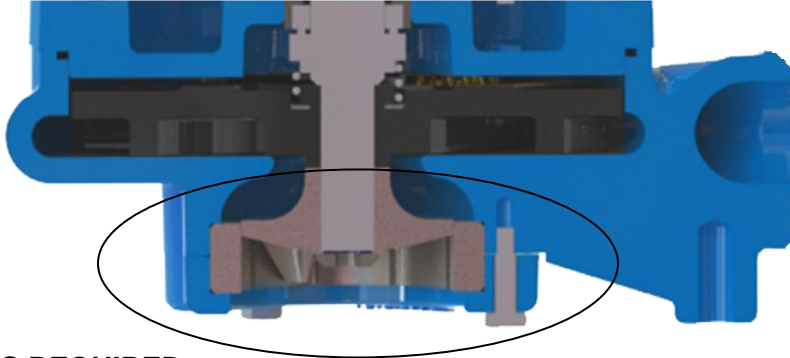

STANDARD TOOLS REQUIRED:

- Standard socket wrench set.
- Standard set of open end wrenches.
- Hammer.
- Vise grip pliers.
- Allen head socket set.
- Screwdrivers.
- Wire brush.

CAUTION – Disconnect all power and control wires to motor at the control panel before starting the disassembly operations. Do not rely upon opening the circuit breaker only.

IMPORTANT – Pump should be sanitized with bleach before starting work.

Pump should be thoroughly cleaned of trash and deposits before starting disassembly operations.

Wear protective gloves and clothing.

Always use a rag on the impeller when turning to prevent cutting hands on the sharp edges of the shredding ring.

DISASSEMBLY OF SHREDDING RING AND GRINDER IMPELLER

1. Hold the grinder impeller by prying against the impeller cutting bar and remove the allen head cap screw from the end of the shaft.
2. Use a large screwdriver in the slot end of the shaft and tap (counterclockwise) on one of the large cutter vanes with a hammer. Tap in a counterclockwise direction (thread is right hand).
3. If the impeller removes easily, clean and replace if worn.
4. Make sure the pump impeller has not loosened when the grinder impeller was removed. This can be checked on reassembly of grinder impeller and shredding ring. The tips of the impeller cutter vanes should extend 1/8” below the bottom of the shredding ring. If the distance is greater, the pump impeller has loosened. If the distance is less, the shredding ring is not properly seated.
5. After the volute case has been removed, insert screwdriver in slot end of shaft and tap hammer against the outer vane of the ductile iron pump impeller (clockwise) to ensure it is threaded tight against shoulder on shaft.
6. Use large screwdriver to tap stainless steel cutter ring from cast iron volute.
7. Clean all threads with a wire brush and file smooth any nicked threads. Use NEVER-SEEZE or other graphite compound on threads before replacing grinder impeller.

8. Make sure allen head cap screw in bottom of pump shaft is tight. Make sure the impeller turns freely by hand after reassembly. Some drag will be present due to the shaft seals. There should not be any binding or tight spots when turning the grinder impeller.

START KIT REPLACEMENT “C” MODEL

1. Place pump in upright position.
2. Loosen cord cap retaining bolts (1). Keen recommends that a rag or towel be wrapped around the joint where the cord cap and bearing housing meet.
3. Slowly move cord cap upward until any pressure that may be present is released, remove the retaining bolts and lift off cord cap.
4. Remove start switch (3) mounting screw and replace start switch as required. Wire per attached diagram and reinstall.
5. Remove bracket mounting screws (4) as required, to lift entire assembly from casting.
6. Remove capacitor screw from backside of dual bracket (5) and replace start/run capacitors as required.
7. Clean mating surfaces and inspect O-Ring for cuts or damage (replace if necessary). Reinstall cord cap.
8. Check power cord at plug with ohm meter for shorts to ground.

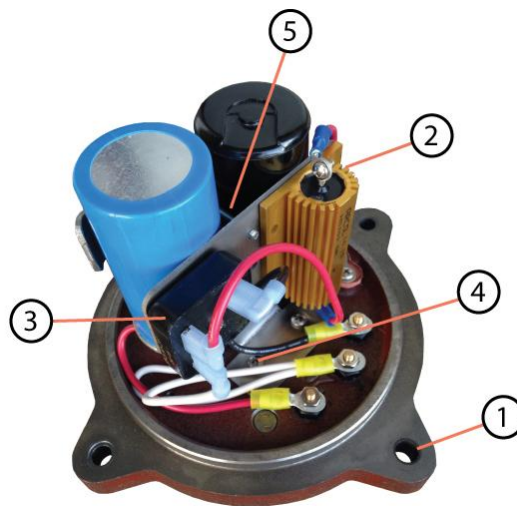

SUBMERGENCE LEVELS - RAIL MOUNTED PUMPS

PUMP	LIFTOUT MODEL	A BOTTOM OF WELL TO INLET	B "KEEN" RECOMMENDED MINIMUM SUBMERGENCE LEVEL
KE102/103	KL2	3-1/2"	15"
KF/HG2	KL1(CV)	3-1/2"	15"
KPCG	KL1(CV)	3-3/4"	19"
K(H)GS2	KL1(CV)	3-3/8"	15"
KHHG2	KL1(CV)	3-1/2"	21"
KHHG2H	KL1(CV)	3-1/2"	21"
KG3,5,7,103	KL3H	4-3/4"	22"
KHG3,5,7	KL3H	5-3/4"	22"
KGP75-150	KL3H	4-3/4"	28"
K3RN	KL3H	5-3/4"	28"
K3VN	KL3H	4-1/2"	27"
K3RH	KL3H	5-3/4"	23"
K4RH	KL4	6-1/4"	24"
K4RN (3450)	KL4	6-1/4"	28"
K4RN (1150/1750)	KL4	5-1/8"	28"
K4VN	KL4	5-1/8"	27"
K4RP (3450)	KL4	5-1/2"	28"
K4RP (1150/1750)	KL4	7-1/2"	32"
K4VP	KL4	7-1/2"	30"
K4RB (3450)	KL4	9-1/8"	36"
K4RB (1750)	KL4	8-1/2"	36"
K4VB	KL4	7-1/2"	35"
K4VK	KL4	6-1/2"	42"
K6VB	KL6	8-3/8"	38"
K8VK	KL8	16"	52"
K12VK	KL12	15-1/2"	61"
K14VK	KL14	15-1/2"	61"

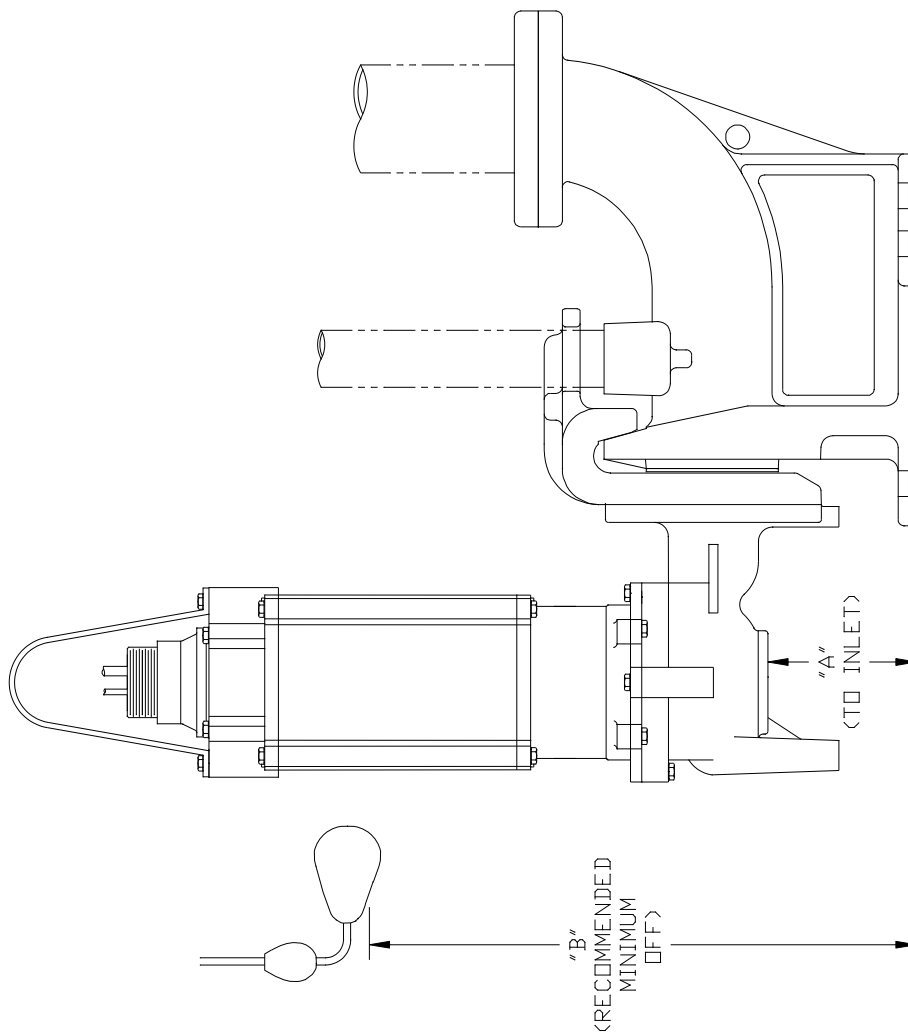

NOTE: ALL DIMENSIONS FOR REFERENCE ONLY

REV	INITIALS	DATE
B	SE	10/09/2015
A	SE	03/16/2015

471 US HWY 250 EAST
ASHLAND, OHIO 44805
PHONE: 419-207-9400
FAX: 419-207-8031

TITLE SUBMERGENCE LEVELS - WASTEWATER PUMPS		DWG. # KN-903	REV. B
SCALE NTS	DATE 9/24/2014		
DWG. BY SE			



471 US Hwy 250 East, Ashland, Ohio 44805
PH: 419-207-9400 FX: 419-207-8031

Limited Warranty

During the time periods and subject to the conditions hereinafter set forth, Keen Pump will repair or replace to the original user or consumer, any portion of your new Keen product which proves defective due to defective materials or workmanship of Keen Pump. Contact your closest authorized Keen Pump representative or distributor for warranty service. At all times, Keen Pump shall have and possess the sole right and option to determine whether to repair or replace defective equipment, parts or components. Damage caused by acts of GOD or conditions beyond the control of Keen Pump is not covered by this warranty.

WARRANTY PERIOD:

36 months from date of manufacture.

Start-up reports are required to support warranty claims. Warranty effective only if Keen Pump supplied or authorized control panels are used. Single phase pumps must utilize Keen Pump supplied start components.

THIS WARRANTY WILL NOT APPLY:

- (1) To defects or malfunctions resulting from failure to properly install, operate or maintained the product in accordance with printed instructions provided.
- (2) To failures resulting from abuse, accident or negligence.
- (3) To normal maintenance services and the parts used in conjunction with such service.
- (4) To products which are not installed in accordance with applicable local codes, ordinances and good trade practices.
- (5) The product is used for purposes other than for what is was designed and manufactured.
- (6) If 3 phase motors are installed on a single phase power supply using a phase converter or if 3 phase power is supplied by only two transformers, making an open Delta system.

WARRANTY EXCLUSIONS:

Keen Pump specifically disclaims the implied warranties of merchantability and fitness for a particular purpose after the termination of the warranty period set forth herein. No warranties or representations at any time made by any representatives of Keen Pump shall vary or expand the provision hereof.

LIABILITY LIMITATION:

In no event shall Keen Pump be liable or responsible for consequential, incidental or special damages resulting from or related in any manner to any Keen Pump product or parts thereof. Personal injury and/or property damage may result from improper installation. Keen Pump disclaims all liability, including liability under this warranty, for improper installation. Keen Pump recommends following the instructions in the installation manual. When in doubt, consult a professional. Some states do not allow the exclusion or limitation of incidental or consequential damages, so the above limitation or exclusion may not apply to you.

LABOR, ETC., COSTS:

Keen Pump shall in no event be responsible or liable for the cost of field labor or other charges incurred by any customer in removing and/or reaffixing any Keen Pump product, part or component thereof or any temporary pumping of other equipment.

RETURNED OR REPLACED COMPONENTS:

Any item to be replaced under this Warranty must be returned to Keen Pump, or such other place as Keen Pump may designate, freight prepaid.

This warranty gives you specific legal rights and other rights which may vary from state to state.

In the absence of suitable proof of this purchase date, the effective date of this warranty will be based upon the date of manufacture. Example: 1501 = Year-Month = 2015, January

Keen Pump Grinder Recommended Limits of Application							
				Simplex		Duplex	
Model	HP	Max. Flow	Max. Head	Homes (EDUs)	Gallons/Day	Homes (EDUs)	Gallons/Day
KPCG	1	15	*	2	800	4	1600
LCG2	2	59	116	4	1600	8	3200
KG2	2	43	106	4	1600	8	3200
KHG2	2	20	130	3	1200	6	2400
KHHG2	2	30	160	3	1200	6	2400
KHHG2H	2	28	225	3	1200	6	2400
KG3	3	183	65	12	4800	25	10000
KG5	5	190	87	25	10000	50	20000
KHG3	3	100	105	6	2400	12	4800
KHG5	5	100	140	8	4000	16	8000
KHG7	7.5	100	170	10	4800	20	10000
KG10	10	185	160	25	10000	50	20000

* KPCG 1hp Progressive Cavity pump Max Head based on Minimum Flow requirements
 Minimum Flow = 6 GPM
 Maximum Head = 225 TDH

