



471 US Hwy 250 East, Ashland, Ohio 44805  
PH: 419-207-9400 FX: 419-207-8031

---

# INSTALLATION AND SERVICE INSTRUCTIONS AND REPAIR PARTS LIST FOR 7.5 HP THRU 15HP CENTRIFUGAL SUBMERSIBLE “HIGH PERFORMANCE” GRINDER SEWAGE PUMPS

---

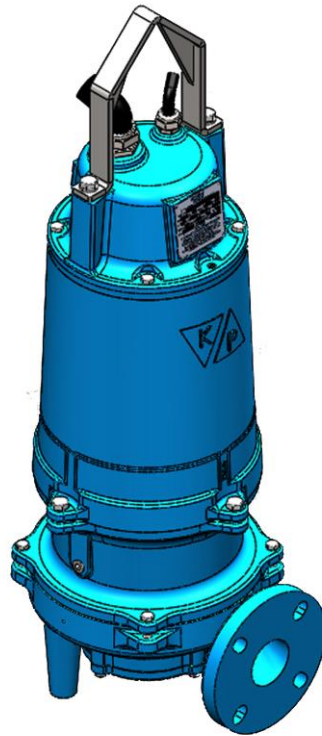

Note! To the installer: Please provide this manual to owner of equipment or to responsible party maintaining the system.

P/N O&M-KGP GRINDER

## MODELS: 7.5hp – 15hp “KGP” Series

<b>Cat. No</b>	<b>HP</b>	<b>PH</b>	<b>VOLT</b>
KGP75M2-03	7.5	3	208
KGP75M2-23	7.5	3	230
KGP75M2-43	7.5	3	460
KGP100M2-03	10	3	208
KGP100M2-23	10	3	230
KGP100M2-43	10	3	460
KGP150M2-03	15	3	208
KGP150M2-23	15	3	230
KGP150M2-43	15	3	460

## General Information

Thank you for purchasing your Keen Pump® submersible solids-handling pump. To assist in ensuring years of trouble-free operation, please read the following manual carefully.

### Prior to Operation:

Carefully read the following instructions. Reasonable care and safe methods should be practiced. Check all local codes and regulations prior to installation.

### Attention:

This product manual contains important and necessary information for the safe use of your Keen Pump® submersible solids handling pump. Read this manual completely prior to using this product and refer to it often for the continued safe use of this product. **DO NOT DISGARD OR LOSE THIS MANUAL.** Procure this manual in a safe place so as it can be referred to often.

### Unpacking Pump:

Carefully remove the pump from the shipping carton and/or pallet. When unpacking the pump, inspect the unit for concealed damage. Claims for damage must be made at the receiving end through the delivery carrier. Shipping damage cannot be processed through or from the factory.

**WARNING: Prior to handling these pumps or controls, always disconnect the power first and adhere to all local codes. Do not smoke or use sparkable electrical devices or flames in or around a septic (gaseous) or a possible septic wet well.**

### CALIFORNIA PROPOSITION 65 WARNING:

**▲WARNING** This product and related accessories contain certain chemicals known to the State of California to cause cancer, birth defects or other reproductive harm.

### Pumps Prior to Operating or in Storage:

The Keen Pump® submersible pump is equipped with silicon-carbide mechanical seals. Pumps constructed with silicon-carbide seals must have the impeller manually rotated at a minimum of 6 revolutions after setting non-operational for 3 weeks or longer prior to electrical start-up.

### Moisture Leak Detection (Seal Failure):

Two electrode probes are installed in the seal chamber between the inboard and outboard mechanical seals. If water is to enter this chamber through the outboard (first) mechanical seal the

electrodes will energize and a signal is transmitted the motor control center indicating the outboard mechanical seal has failed. The moisture leak detection probes are installed in all Keen Pump® submersible pumps, although the sensing unit in the motor control center is not supplied unless ordered separately from the factory.

In operation the moisture leak detectors only indicate that moisture/water has entered the seal chamber through the outboard seal. The pump will continue to operate without damage, the warning indicated at the motor control center implies that the outboard mechanical seal should be checked and serviced immediately.

**CAUTION: Failure to correct and service the pump of the failed seal could result in water entering the motor chamber and causing the motor to short out.**

**WARNING: Failure to correctly connect the moisture sensor circuit will void the Keen Pump® warranty.**

The sensing unit at the motor control center is recommended by the factory on all installations as a good insurance against motor failure and to not void the warranty.

### Pump:

The power cable supplied on the unit is equipped with a separate wire for ground. Make sure this green ground wire is connected to a good ground such as a water pipe of grounding stake.

### Heat Sensors:

All motors constructed in this submersible pump have heat sensors embedded in the stator windings to detect excessive heat. The heat sensors are designed and set to trip at 105° C, the sensor will open at the designed rating sending a signal back to the motor control center and not allow the pump to operate when excessive heat is detected. The sensors will automatically reset when the motors cools to a safe temperature.

The sensors are connected in series with the motor starter coil so that the starter is tripped when the heat sensor opens. The motor starter is equipped with overload heaters so all normal overloads are protected by the starter.

**IMPORTANT: If Keen Pump® electrical starting equipment is not supplied, the heat sensor circuit must be connected in series with the starter coil or warranty is void.**

**Wet Well Level Control:**

Wet well level is controlled by Keen Pump® float switch controls. The float is secured in position in the wet well by a weight attached to the control cord above the float. The cord supports the float and is adjusted for height of operation from the surface of the wet well.

Typical duplex systems use three controls: one control set at the turn-off, one control set at turn-on for one pump, and one control set for turn-on for two pumps. Pumps are typically set to alternate operation on each successive cycle.

Two pumps operate together only if the wet well level rises to the third or override control. The override control also operates the second pump in the event of failure of the first pump.

Triplex systems use four controls: One set at the turn-off position, one set at turn-on one pump, one set at turn-on for two pumps, one set at turn-on for three pumps. Pumps will alternate at each successive cycle.

Three pumps will operate at the same time only if the wet well level rises to the fourth control (second override). The fourth control also energizes the third pump in the event that either or both of the first two pumps have failed.

Additional float controls can be installed with appropriate controls for other alarm functions in the wet well.

**Alarm Controls:**

The alarm level is typically set above the override level so the alarm will signal only if the override level in the wet well is exceeded. However, some engineers prefer to have the alarm level set below the override as an indicator that one pump may have failed and the other pump(s) are operating on the override control and the event that the wet well level never reaches the alarm level if it is set above the override level. This is particularly the case of low inflow capacity.

**WIRE SIZE AND MAXIMUM LENGTH (FEET) FOR REMOTE LOCATION OF CONTROL PANEL  
BASED ON A 2% VOLTAGE DROP (230 VOLTS 3 PHASE)**

Copper Wire		Amperes @ 230 Volts*																		
No.	D.C. Res. AWG /M Ft.	5	10	15	20	25	30	40	50	60	70	80	90	100	120	140	160	180	200	
12	1.620	325	165	110	80	65	55													
10	1.018	520	260	175	130	105	85	65												
8	0.6404	830	415	275	205	165	140	105	80											
6	0.410	1295	645	430	320	260	215	160	130	105	90	80								
4	0.259		1025	680	510	410	340	255	205	170	145	130	115	100	85					
M 3	0.205		1295	865	650	520	430	325	260	215	185	160	145	130	110	90				
2	0.162			1090	820	655	545	410	340	295	255	230	205	180	160	135	110	100		
1	0.129				1030	825	685	515	410	340	295	255	230	205	170	145	130	115		
0	0.102					1040	865	650	520	435	370	325	290	260	215	185	160	145	130	
00	0.0811						1090	820	655	545	470	410	365	325	270	235	205	180	165	
000	0.0642							1035	825	690	590	515	460	415	345	295	260	230	205	

NOTE: For 460 volts obtain distance by multiplying by 2.0  
 For 570 volts obtain distance by multiplying by 2.5  
 \* 230 volt system not recommended for above 30 to 40 horsepower.  
 ‡ Based on 3 power conductors in cable or conduit; for 4 to 6 reduce ampacity to 80% & for 7 to 24 reduce to 70%.  
 M. Special junction box required for wire sizes larger than #4.

**NUMBER OF CONDUCTORS REQUIRED BETWEEN CONTROL PANEL AND NEMA 4 JUNCTION BOX  
Power lines and control wires can be carried in conduit or can be underground buried cable.**

System Type	Number of Control Wires	Number of Power Lines	Number of Ground Wires #8	HEAT SENSOR & SEAL FAILURE	
				Number of Sensor Wires	Number of Ground Wires
Simplex	3	3	1	3	1
Simplex with Alarm	5	3	1	3	1
Duplex	5	6	1	6	2
Duplex with Alarm	7	6	1	6	2

### Electrical Control Panel:

The factory recommends that a Keen Pump® control be used with all pumps as proper starter heaters and connections for heat sensor wires will be furnished. The electrical equipment includes a main circuit breaker for each pump, a magnetic starter with overload protection for each pump, an H-O-A switch and run light for each pump, an electrical alternator and transformer to provide the necessary and appropriate control circuit and alarms.

### Overload Heaters:

If the Keen Pump® electrical control panel is not used, starters with three leg overload protection must be supplied. The heaters must be appropriately sized in accordance with the nameplate amps on the pump. The pump amp draw on these submersible motor will be higher than a NEMA® general purpose motor, so heaters must be sized by the nameplate rating.

## Pump Installation

### Installing Pump in Wet Well:

Prior to installing the pump in the wet well, lay the pump on its side and ensure the impeller will turn manually. Impeller may be slightly stuck due to the factory water test, the impeller must be broken loose with a small bar or screwdriver in the edge of the vanes. The impeller must turn freely. Ensure all trash and debris is cleaned from the wet well and connect pump to the piping. A check valve must be installed on each pump. A plug or gate valve is recommended by the factory on the discharge side of the pump also. The valve should be installed on the discharge side of the check valve so if necessary to service the check valve the line pressure can be shut off. Single pump installations are sometimes designed without a check valve where it is desirable to self drain the discharge line to prevent freezing. This should only be done with short discharge lines, otherwise water will return into the wet well and cause short cycling of the pump.

### NEMA® 4 Junction Box (Optional):

If the electrical control panel is to be set remote from the pump wet well a NEMA® 4 junction box should be used to make the necessary power and control connections. The Keen Pump® NEMA 4 junction box is provided with compression connectors for sealing all wires. No sealing compound is necessary to make connections watertight. Wiring diagrams are provided with panel for making connections. The necessary wire size to use from the panel to the wet well depends on motor size and distance in feet.

**CAUTION: Ensure all local codes are followed when sizing wire.**

Be sure each wire is checked out so that an incorrect connection is not made. An ohmmeter or Megger can be used to check wire continuity.

### Installing Float Switch Controls:

The control floats are supported by a mounting bracket that is attached to the wet well wall or cover or to the NEMA 4 junction box.

Cord bushings/snubbers are used to hold the cord in place. The control level can be adjusted at any time by loosening the bushing/snubber and readjusting cord length.

In a simplex and/or a duplex system the lower or turn-off control is set at a minimum just above the top of the volute so as the volute is always submerged during the pumping cycle. The second or turn-on control is at a minimum 24 inches above the lower or turn-off control.

More distance can be made between the turn-on and turn-off controls, but sewage may become septic and excessive solids may collect for the pump to handle. A frequent pumping cycle is recommended for best operation.

If an alarm control is used, this control is usually set about 6 inches above the override control.

### Making Electrical Connections:

All electrical wiring must be in accordance with all local codes and only competent electricians should make all connections. Complete wiring diagrams are included in all Keen Pump® supplied control panels. All wires should be checked for grounds with an ohmmeter or Megger after connections are made. *This is important, as a grounded wire can cause considerable trouble.*

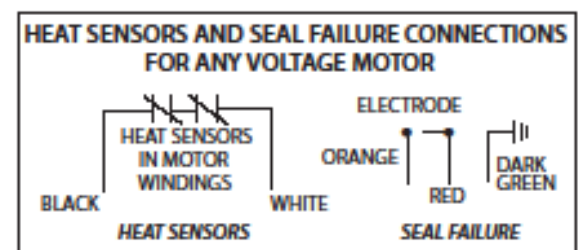
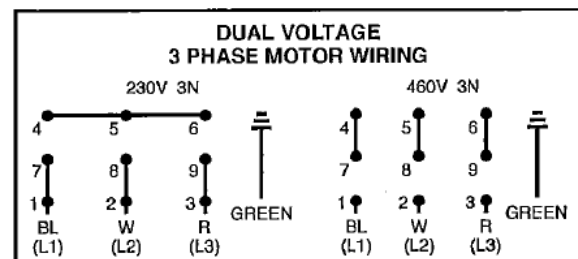

**IMPORTANT:** If equipment is not properly wired and protected as recommended, the warranty is void.

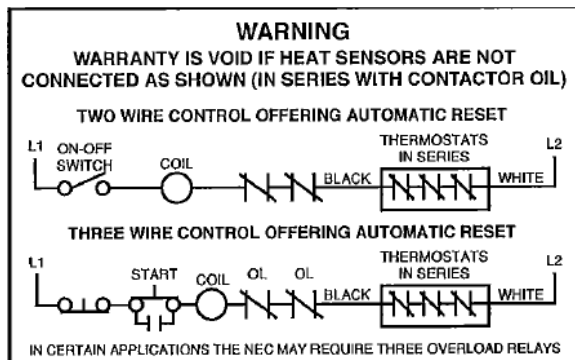

### Heat Sensors and Seal Failure Connections:

Be sure that heat sensor wires are connected in series with the starter coil. Connections are provided on the terminal strip.

## Pump Operation

### Starting Systems:

1. Turn the H-O-A switch to the Off position, then turn on the main circuit breakers.
2. Open all discharge valves and allow water to rise in the wet well.
3. Turn H-O-A switch to Hand position on one pump and inspect operation. If pump is noisy and vibrates, rotation is wrong. To change rotation interchange two motor leads on 3Ø only. **DO NOT INTERCHANGE MAIN INCOMING LINES.** If a duplex installation, check the second pump in the same manner.
4. Now set the H-O-A switch(es) to Auto position and allow water to rise in the wet well until one pump starts. Allow pump to operate until the level drops to turn-off point.
5. Allow the wet well level to rise to start the second pump. Notice the run lights on the control panel, pumps should alternate on each successive cycle of operation.
6. Turn the H-O-A switches to the Off position and allow wet well to fill to the override control level.
7. Turn both H-O-A switches to Auto position and both pumps should start and operate together until level drops to the turn-off control.
8. Repeat this operation cycle several times before leaving the job site.
9. Check voltage and amp draw on each pump when they are operating. The amp draw should be checked on each leg, a high leg may exist. A 5-10% difference may exist and is satisfactory;

any variation greater than that then the power company should be consulted.

### Phase Converters:

Phase converters are generally not recommended, but in case where only single phase power is available a phase converter can be used. Be sure to size the phase converter large enough for the amp draw specified on the motor nameplate, not necessarily by motor horsepower. The warranty on all three phase submersible pumps is void if operated with single phase power through a phase converter and 3 leg ambient compensated extra-quick trip overload protectors are not used.

## Pump Maintenance

### Maintenance:

As all motors are oil filled, no lubrication or other such maintenance is required.

If the pump is used on a rail system, it should be lifted once every six months and inspected for corrosion and wear.

Generally these pumps give very reliable service and can be expected to operate for years under normal sewage pumping applications without failure.

### Lightning:

In areas where electrical storms producing considerable lightning it is recommended that a lightning arrestor be installed at the control panel. Lightning arrestors are a good insurance against damage to an expensive motor.

### Servicing Instructions:

#### **WARNING! Field Service on KEEN PUMP Hazardous Location Pumps:**

All FM Approved Hazardous Locations Certified submersible motors must be returned to the factory for service or repaired at an authorized Keen Pump® service center or a repair shop that is audited by FM Approvals and has access to Keen Pump® design drawings. Failure to follow these instructions will invalidate the certification of motor. Charges will not be allowed if pump is not serviced by an authorized Keen Pump® service center. When field service is performed on a pump, these instructions should be carefully adhered to.

### Replacing the Stator:

1. If the stator only is damaged, it is possible that the entire pump may not have to be disassembled. The stator and housing can be removed from the pump without disturbing seals or bearings.
2. Drain all oil from the upper motor housing, remove drain plug in bottom seal housing and

- remove plug from side of stator housing to allow air to enter.
3. After chamber is drained of oil, remove fasteners connecting motor housing to seal housing and lift off. **CAUTION:** in lifting the assembly off as the seal failure wires will still be connected to the seal sensor probes and will need to be disconnected before the assembly is completely lifted off.
  4. Set the assembly on the bench and removed cord cap. When the cap is lifted off the wire connection to the terminal plate will be exposed. Wires may be burned. Loosen fasteners from terminal plate connections and set the cap on the bench. If the wires are damaged in the cord cap then a new cord cap will be required from the factory because the power and control cords are potted in the cord cap.
  5. Loosen the fasteners securing the terminal plate to the motor housing and lift the terminal plate off the housing. Be careful the stator leads are connected to the underside of the terminal plate. The fasteners securing the stator leads to the terminal plate will need to be removed and the terminal plate placed on the bench.
  6. The stator is clamped and keyed in the housing. Remove fasteners securing clamp ring and remove clamp ring. The stator and housing may need to be bumped on the bench to allow the stator to be removed from the housing.
  7. Thoroughly clean the housing and re-install new stator.
  8. Replace all o-rings used in the re-assembly of the unit.
  9. Reinstall stator and housing assembly on pump.
  10. Make stator lead connections to terminal plate and then reinstall terminal plate. Ensure load springs are located in terminal plate bearing bore.
  11. Make power and control cord connections in the cord cap to the terminal plate and reinstall cord cap.
  12. Reinstall lower plug that was removed to drain the oil. Add Permatex® to the threads for the plug.
  13. In the upper plug in the stator housing install an air valve and charge the housing with 10 psi to verify air tight assembly.
  14. Fill the stator housing with Keen Pump® submersible oil. At a minimum the oil should cover the top of the windings. Install plug use Permatex® on the threads.
  4. Loosen bolts securing the seal housing to the volute and remove assembly from the volute case.
  5. Carefully lay the assembly on its side and remove bolt holding the impeller to the shaft. Break the impeller loose from the shaft tapping with hardwood blocks.
  6. Loosen fasteners securing the seal plate from the seal housing. **NOTE:** The outboard seal stationary primary ring will remain in the seal pocket.
  7. With a bearing puller remove the seal ring which is securing the position of the inboard seal from shaft.
  8. Bump the end of the shaft with hardwood blocks to remove the rotor and shaft assembly from the seal housing.
  9. Bearings can be removed from shaft and replaced with new bearings. **NOTE:** If the lower bearing is an angular contact bearing take note of proper installation.
  10. Replace all o-rings as described.
  11. Reinstall rotor shaft assembly into the seal housing.
  12. Reinstall stator housing onto seal housing and secure.
  13. Make stator lead connections to terminal plate install as described.
  14. Secure pump on the terminal plate and install inboard seal into seal housing. Reinstall seal ring to shaft. Install an air valve in the stator housing and charge motor chamber with 10 psi to check the inboard seal.
  15. Reinstall seal plate to seal housing, install outboard seal and reinstall impeller.
  16. Install an air valve and charge to seal chamber with 10 psi to check the outboard seal.
  17. Reinstall assembly to volute and secure.
  18. Reinstall cord cap and make connections to terminal plate.

#### **Replacing Seals:**

1. Drain seal chamber as described.
2. Remove impeller as described.
3. Remove outboard seal as described.
4. Remove inboard seal as described.
5. Replace all o-rings as described.
6. Reinstall new inboard and outboard seals and test seals as described.

#### **Replacing Bearings:**

1. Drain all oil from motor chamber as described.
2. Remove motor housing as described.
3. Drain the oil for the seal chamber by removing plug on the side of the seal chamber.

## Pump Troubleshooting

The following is a list of common problems and their subsequent probable causes:

### **Pump will not start.**

1. No power to the motor. Check for blown fuses or tripped circuit breakers.
2. The H-O-A selector switch may be in the Off position.
3. Control circuit transformer fuse may be blown.
4. Overload heater on starter may be tripped. Push to reset.

### **Pump will not start and overload heaters trip.**

1. Turn off power and check motor leads with an ohmmeter or Megger for possible ground.
2. Check resistance of motor windings. All 3 phases should have equal readings.
3. If no grounds exist and the windings check satisfactory, remove pump from wet well and check for clogged or blocked impeller.

### **Pump operates with H-O-A selector switch in the Hand position but will not operate in Auto position.**

1. This indicates trouble in the float level control or the alternator relay.
2. Check control panel for trouble.

### **Pump operates but will not shut off.**

1. Pump may be air locked. Turn pump off and let set for several minutes, and then restart.
2. Lower float control may be hung-up in the closed position. Check in the wet well to be sure control is free.
3. H-O-A selector switch may be in the hand position.

### **Pump does not deliver proper capacity.**

1. Discharge gate valve may be partially closed or partially clogged.
2. Check valve may be partially clogged. Raise level up and down to clear.
3. Pump may be running in the wrong direction. Low speed pumps can operate in reverse direction without much noise or vibration.
4. Discharge head may be too high. Check total head pressure with gauge when pump is operating. Total head pressure is discharge gauge pressure converted to feet plus vertical height from water level in the wet well to center line of pressure gauge in the discharge line. Gauge should be installed on pump side of all valves. To convert pressure gauge reading in PSI to head in feet multiply by 2.31.
5. If pump has been in service for a lengthy period of time and capacity has reduced, remove pump and check impeller, volute and volute wear ring for wear.

### **Motor stops and then restarts after a short period but overload heaters in the starter do not trip.**

1. This indicates heat sensors in the motor are tripping due to excessive heat. Impeller may be partially clogged giving a sustained overload but not high enough to trip overload heat switch.
2. Motor may be operating out of liquid due to a failed level control.
3. Pump may be operating on a short cycle due to wet well being too small or from water returning to wet well due to a leaking check valve.

# WIRING DIAGRAMS

## 208 Volt, 3-Phase

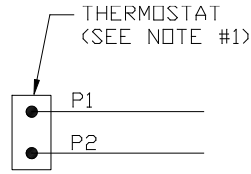

NOTE #1 - WHEN MORE THAN ONE THERMOSTAT IS USED, CONNECT IN SERIES

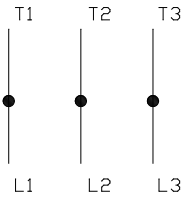

NOTE: TO REVERSE ROTATION, INTERCHANGE THE EXTERNAL CONNECTIONS TO ANY TWO LINE LEADS.

### **RESISTANCE – 7.5hp**

WIRE	208V OHM
BLACK TO WHITE	
RED TO WHITE	
BLACK TO RED	

### **RESISTANCE – 10hp**

WIRE	208V OHM
BLACK TO WHITE	.347
RED TO WHITE	.347
BLACK TO RED	.347

### **RESISTANCE – 15hp**

WIRE	208V OHM
BLACK TO WHITE	.289
RED TO WHITE	.289
BLACK TO RED	.289

## 230/460 Volt, 3-Phase

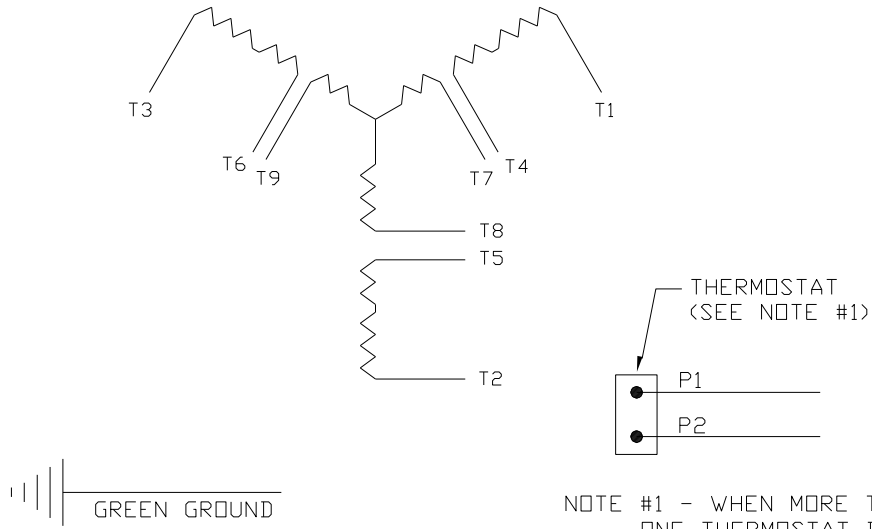

NOTE #1 - WHEN MORE THAN ONE THERMOSTAT IS USED, CONNECT IN SERIES

LOW VOLTAGE

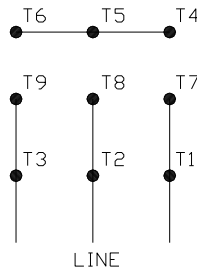

HIGH VOLTAGE

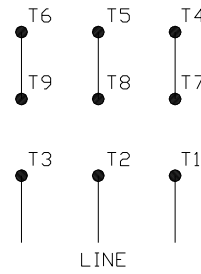

NOTE: TO REVERSE ROTATION, INTERCHANGE THE EXTERNAL CONNECTIONS TO ANY TWO LINE LEADS.

### RESISTANCE - 7.5hp

WIRE	230V OHM	460V OHM
BLACK TO WHITE		
RED TO WHITE		
BLACK TO RED		

## 230/460 Volt, 3-Phase, (cont.)

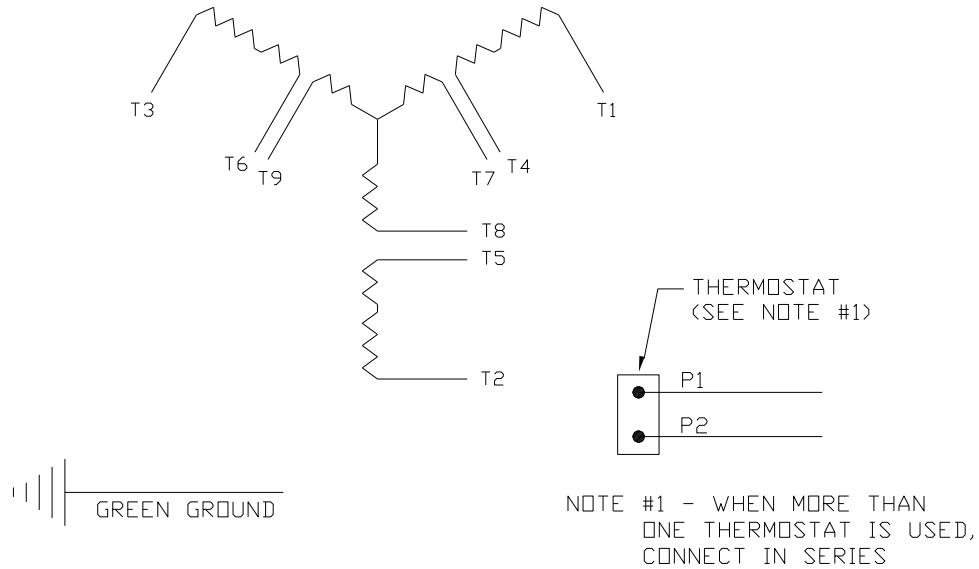

LOW VOLTAGE

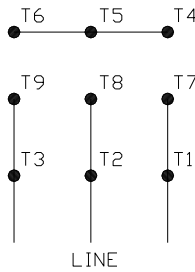

HIGH VOLTAGE

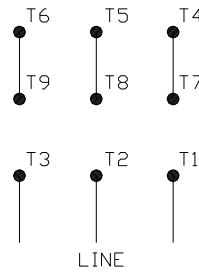

NOTE: TO REVERSE ROTATION, INTERCHANGE THE EXTERNAL CONNECTIONS TO ANY TWO LINE LEADS.

### RESISTANCE – 10hp

WIRE	230V OHM	460V OHM
BLACK TO WHITE	.504	2.014
RED TO WHITE	.504	2.014
BLACK TO RED	.504	2.014

### RESISTANCE – 15hp

WIRE	230V OHM	460V OHM
BLACK TO WHITE	.362	1.448
RED TO WHITE	.362	1.448
BLACK TO RED	.362	1.448

# REPAIR PARTS LIST

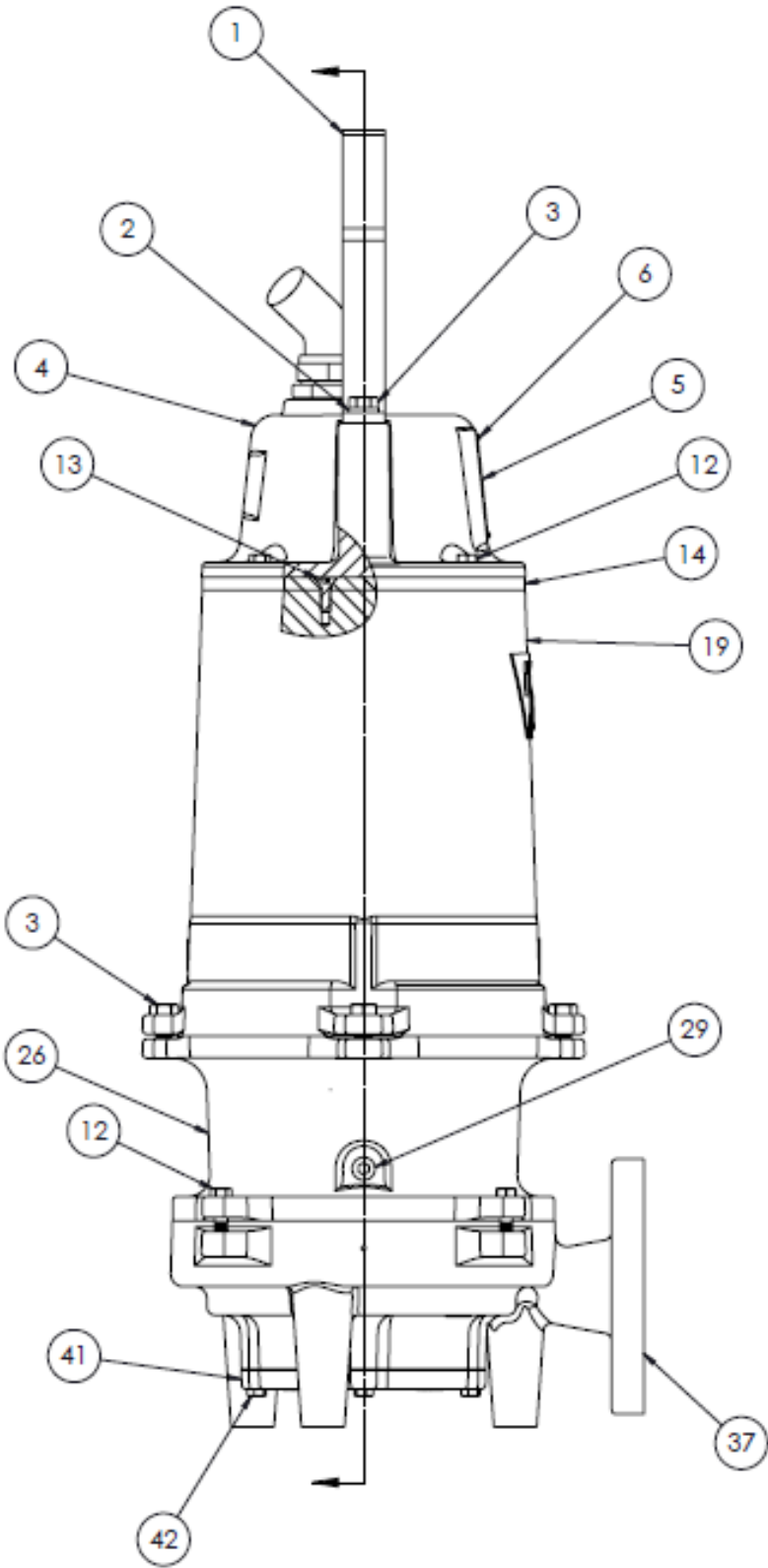

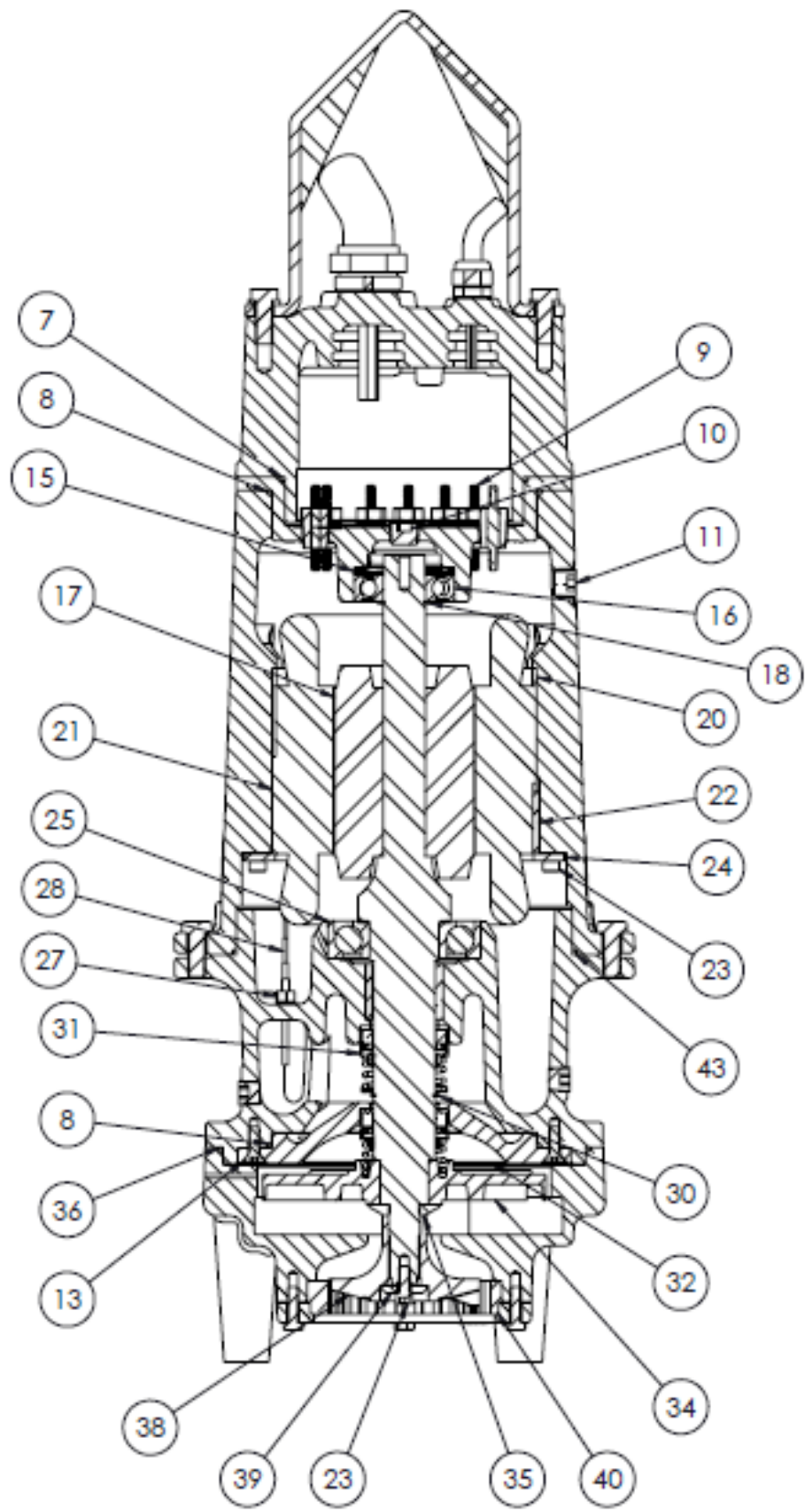

ITEM NO.	PART NUMBER	DESCRIPTION	QTY.
1	K0368-1-05	LIFTING BAIL	1
2	LWASH1/2SS	LOCK WASHER	2
3	CS1/2X1-1/4SS	CAP SCREW	6
4	K0365-5-40	CORD CAP ASSEMBLY - 10-4	1
	K0366-5-40	CORD CAP ASSEMBLY - 8-4	
	K0369-5-40	CORD CAP ASSEMBLY - 6-4	
5	KNP0001	PUMP NAMEPLATE	1
6	DS4X3/16SS	DRIVE SCREW	4
7	K0166-1-18	O-RING	1
8	K0166-1-02	O-RING	2
9	K0148-5-01	ELECTRICAL TERMINAL - 230-460/3/60	13
		ELECTRICAL TERMINAL - 208/3/60 & 575/3/60	7
10	K0107-1-02	PIPE PLUG - 230-460/3/60	1
		PIPE PLUG - 208/3/60 & 575/3/60	7
11	K0107-1-01	PIPE PLUG	1
12	CS3/8X1-3/4SS	CAP SCREW	8
13	SC55/16X1SS	CAP SCREW	8
14	K0293-2-01	TERMINAL PLATE	1
15	K0150-1-03	LOAD SPRING	2
16	K0102-1-07	BALL BEARING	1
17	K0356-5-02	ROTOR SHAFT ASSEMBLY	1
18	K0167-1-05	RETAINING RING	1
19	K0298-2-01	MOTOR HOUSING	1
20	K0362-1-01	STATOR SPACING RING	1
21	K0356-1-03	STATOR - 10-15HP, 208/3/60	1
	K0356-1-23	STATOR - 10-15HP, 230-460/3/60	
	K0356-1-53	STATOR - 10-15HP, 575/3/60	
	K0357-1-03	STATOR - 7.5HP, 208/3/60	
	K0357-1-23	STATOR - 7.5HP, 230-460/3/60	
	K0357-1-53	STATOR - 7.5HP, 575/3/60	
22	K0358-3-01	STATOR KEY (3 Ø)	1
23	SC55/16X3/4SS	CAP SCREW	9
24	K0338-3-01	STATOR CLAMP RING	1
25	K0103-1-03	ANGULAR CONTACT BEARING	1
26	K0299-5-01	BEARING FRAME ASSEMBLY	1
27	K0141-5-04	MOISTURE SENSOR PROBE	2
28	K0142-1-02	MOISTURE SENSOR WIRE ASSEMBLY	2
29	PLUG3/8	PIPE PLUG	2
30	K0167-1-04	RETAINING RING	1
31	K0290-1-02	MECHANICAL SEAL	2
32	K0291-2-01	SEAL PLATE	1
33	K0189-3-07	IMPELLER KEY	1
34	K0394-2-01	IMPELLER - 15HP	1
	K0394-2-06	IMPELLER - 10HP	
	K0394-2-13	IMPELLER - 7.5HP	
35	K0411-3-01	IMPELLER NUT	1
36	K0166-1-17	O-RING	1
37	K0395-2-01	VOLUTE	1
38	KG5026-11	ROTATING CUTTER	1
39	KG5029	IMPELLER WASHER	1
40	KG5027-11	GRINDER SHREADING RING	1
41	KG5032-2	RETAINING PLATE	1
42	CS5/16X1SS	CAP SCREW	4
43	K0166-1-06	O-RING	1

PUMP MODEL	HP	VOLTAGE	Ø	Hz.	COMMON PG	MOTOR PG	IMPELLER P/N	IMPELLER DIA.	CORD CAP ASS'Y	WET END PG	PACKAGING PG
KGP150M2-03	15	208	3	60	K0359-4-100	K0360-4-100	K0394-2-01	8.00"	K0369-5-40	K0361-4-100	K0108-4-02
KGP150M2-23	15	230	3	60	K0359-4-100	K0360-4-101	K0394-2-01	8.00"	K0369-5-40	K0361-4-100	K0108-4-02
KGP150M2-43	15	460	3	60	K0359-4-100	K0360-4-102	K0394-2-01	8.00"	K0366-5-40	K0361-4-100	K0108-4-02
KGP150M2-53	15	575	3	60	K0359-4-100	K0360-4-103	K0394-2-01	8.00"	K0366-5-40	K0361-4-100	K0108-4-02
KGP100M2-03	10	208	3	60	K0359-4-100	K0360-4-100	K0394-2-06	7.38"	K0369-5-40	K0361-4-100	K0108-4-02
KGP100M2-23	10	230	3	60	K0359-4-100	K0360-4-101	K0394-2-06	7.38"	K0366-5-40	K0361-4-100	K0108-4-02
KGP100M2-43	10	460	3	60	K0359-4-100	K0360-4-102	K0394-2-06	7.38"	K0366-5-40	K0361-4-100	K0108-4-02
KGP100M2-53	10	575	3	60	K0359-4-100	K0360-4-103	K0394-2-06	7.38"	K0366-5-40	K0361-4-100	K0108-4-02
KGP75M2-03	7.5	208	3	60	K0359-4-100	K0360-4-104	K0394-2-13	6.50"	K0366-5-40	K0361-4-100	K0108-4-02
KGP75M2-23	7.5	230	3	60	K0359-4-100	K0360-4-105	K0394-2-13	6.50"	K0366-5-40	K0361-4-100	K0108-4-02
KGP75M2-43	7.5	460	3	60	K0359-4-100	K0360-4-106	K0394-2-13	6.50"	K0366-5-40	K0361-4-100	K0108-4-02
KGP75M2-53	7.5	575	3	60	K0359-4-100	K0360-4-107	K0394-2-13	6.50"	K0366-5-40	K0361-4-100	K0108-4-02

MOTOR PARTS GROUPS					
PART NUMBER	DESCRIPTION	10-15HP			
		K0360-4-100	K0360-4-101	K0360-4-102	K0360-4-103
		208/3/60	230/3/60	460/3/60	575/3/60
CHARTED	STATOR	K0356-1-03	K0356-1-23	K0356-1-23	K0356-1-53
CHARTED	RING-TERMINAL - STATOR (QTY)	K0191-1-04 (3)	K0191-1-03 (9)	K0191-1-03 (9)	K0191-1-03 (3)
K0356-5-02	ROTOR/SHAFT ASS'Y	1	1	1	1
K0362-1-01	STATOR SPACER RING	1	1	1	1
K0191-1-02	RING-TERMINAL (H.S.)	2	2	2	2
K0191-1-01	RING-TERMINAL (M.S.)	2	2	2	2
K0148-5-01	ELECTRICAL TERMINAL	7	13	13	7
K0107-1-02	PIPE PLUG	7	1	1	7
K0193-1-01	JUMPER WIRE	---	5	3	---
K0194-1-01	LOCK NUT	14	26	26	14
K0181-1-01	OIL	2.1 GAL	2.1 GAL	2.1 GAL	2.1 GAL
K0358-3-01	STATOR KEY	1	1	1	1
PART NUMBER	DESCRIPTION	7.5HP			
		K0360-4-104	K0360-4-105	K0360-4-106	K0360-4-107
		208/3/60	230/3/60	460/3/60	575/3/60
CHARTED	STATOR	K0357-1-03	K0357-1-23	K0357-1-23	K0357-1-53
CHARTED	RING-TERMINAL - STATOR (QTY)	K0191-1-03 (3)	K0191-1-03 (9)	K0191-1-03 (9)	K0191-1-03 (3)
K0356-5-02	ROTOR/SHAFT ASS'Y	1	1	1	1
K0362-1-01	STATOR SPACER RING	1	1	1	1
K0191-1-02	RING-TERMINAL (H.S.)	2	2	2	2
K0191-1-01	RING-TERMINAL (M.S.)	2	2	2	2
K0148-5-01	ELECTRICAL TERMINAL	7	13	13	7
K0107-1-02	PIPE PLUG	7	1	1	7
K0193-1-01	JUMPER WIRE	---	5	3	---
K0194-1-01	LOCK NUT	14	26	26	14
K0181-1-01	OIL	2.1 GAL	2.1 GAL	2.1 GAL	2.1 GAL
K0358-3-01	STATOR KEY	1	1	1	1

<b>COMMON PG - K0359-4-100</b>		
<b>PART NUMBER</b>	<b>DESCRIPTION</b>	<b>QTY</b>
K0368-1-05	LIFTING BAIL	1
LWASH1/2SS	LOCK WASHER	2
CS1/2X1-1/4SS	CAP SCREW	6
KNP0001	PUMP NAMEPLATE	1
DS4X3/16SS	DRIVE SCREW	4
K0166-1-18	O-RING	1
K0166-1-02	O-RING	2
K0107-1-01	PIPE PLUG	1
CS3/8X1-3/4SS	CAP SCREW	8
SC55/16X1SS	CAP SCREW	8
K0293-2-01	TERMINAL PLATE	1
K0150-1-03	LOAD SPRING	2
K0102-1-07	BALL BEARING	1
K0167-1-05	RETAINING RING	1
K0298-2-01	MOTOR HOUSING	1
SC55/16X3/4SS	CAP SCREW	8
K0338-3-01	STATOR CLAMP RING	1
K0103-1-03	ANGULAR CONTACT BEARING	1
K0299-5-01	BEARING FRAME ASSEMBLY	1
K0141-5-04	MOISTURE SENSOR PROBE	2
K0142-1-02	MOISTURE SENSOR WIRE ASSY	2
PLUG3/8	PIPE PLUG	2
K0167-1-04	RETAINING RING	1
K0290-1-02	MECHANICAL SEAL	2
K0291-2-01	SEAL PLATE	1
K0166-1-17	O-RING	1
K0166-1-06	O-RING	1
<b>WET END PG - K0361-4-100</b>		
<b>PART NUMBER</b>	<b>DESCRIPTION</b>	<b>QTY</b>
SC55/16X3/4SS	CAP SCREW	1
K0189-3-07	IMPELLER KEY	1
K0411-3-01	IMPELLER NUT	1
K0395-2-01	VOLUTE	1
KG5026-11	ROTATING CUTTER	1
KG5029	IMPELLER WASHER	1
KG5027-11	GRINDER SHREDDING RING	1
KG5032-2	RETAINING PLATE	1
CS5/16X1SS	CAP SCREW	4
<b>PACKAGING PG - K0108-4-02</b>		
<b>PART NUMBER</b>	<b>DESCRIPTION</b>	<b>QTY</b>
K0295-1-01	SHIPPING SKID	1
CS1/2X2ZN	CAP SCREW	3
LWASH1/2ZN	LOCK WASHER	3
WASH1/2ZN	FLAT WASHER	3
K0329-1-01	LARGE WASHER	3



471 US Hwy 250 East, Ashland, Ohio 44805  
PH: 419-207-9400 FX: 419-207-8031

## Limited Warranty

During the time periods and subject to the conditions hereinafter set forth, Keen Pump will repair or replace to the original user or consumer, any portion of your new Keen product which proves defective due to defective materials or workmanship of Keen Pump. Contact your closest authorized Keen Pump representative or distributor for warranty service. At all times, Keen Pump shall have and possess the sole right and option to determine whether to repair or replace defective equipment, parts or components. Damage caused by acts of GOD or conditions beyond the control of Keen Pump is not covered by this warranty.

### WARRANTY PERIOD:

36 months from date of manufacture.

Start-up reports are required to support warranty claims. Warranty effective only if Keen Pump supplied or authorized control panels are used. Single phase pumps must utilize Keen Pump supplied start components.

### THIS WARRANTY WILL NOT APPLY:

- (1) To defects or malfunctions resulting from failure to properly install, operate or maintained the product in accordance with printed instructions provided.
- (2) To failures resulting from abuse, accident or negligence.
- (3) To normal maintenance services and the parts used in conjunction with such service.
- (4) To products which are not installed in accordance with applicable local codes, ordinances and good trade practices.
- (5) The product is used for purposes other than for what is was designed and manufactured.
- (6) If 3 phase motors are installed on a single phase power supply using a phase converter or if 3 phase power is supplied by only two transformers, making an open Delta system.

### WARRANTY EXCLUSIONS:

Keen Pump specifically disclaims the implied warranties of merchantability and fitness for a particular purpose after the termination of the warranty period set forth herein. No warranties or representations at any time made by any representatives of Keen Pump shall vary or expand the provision hereof.

### LIABILITY LIMITATION:

In no event shall Keen Pump be liable or responsible for consequential, incidental or special damages resulting from or related in any manner to any Keen Pump product or parts thereof. Personal injury and/or property damage may result from improper installation. Keen Pump disclaims all liability, including liability under this warranty, for improper installation. Keen Pump recommends following the instructions in the installation manual. When in doubt, consult a professional. Some states do not allow the exclusion or limitation of incidental or consequential damages, so the above limitation or exclusion may not apply to you.

### LABOR, ETC., COSTS:

Keen Pump shall in no event be responsible or liable for the cost of field labor or other charges incurred by any customer in removing and/or reaffixing any Keen Pump product, part or component thereof or any temporary pumping of other equipment.

### RETURNED OR REPLACED COMPONENTS:

Any item to be replaced under this Warranty must be returned to Keen Pump, or such other place as Keen Pump may designate, freight prepaid.

This warranty gives you specific legal rights and other rights which may vary from state to state.

In the absence of suitable proof of this purchase date, the effective date of this warranty will be based upon the date of manufacture. 1501 = Year-Month = 2015, January P/N O&M-KGP(X)\_GRINDER