



HIGH PRESSURE PUMPS

“2-Stage Centrifugal”



NEWLY UPGRADED CONSTRUCTION TO INCLUDE:

- Powder Coat Paint Finish
- Double Row Rear Bearing For Stronger Loading
- O-ring Seal For Best Design
- Upgrade From ASTM Class 30 to 35 For Stronger Casting Construction

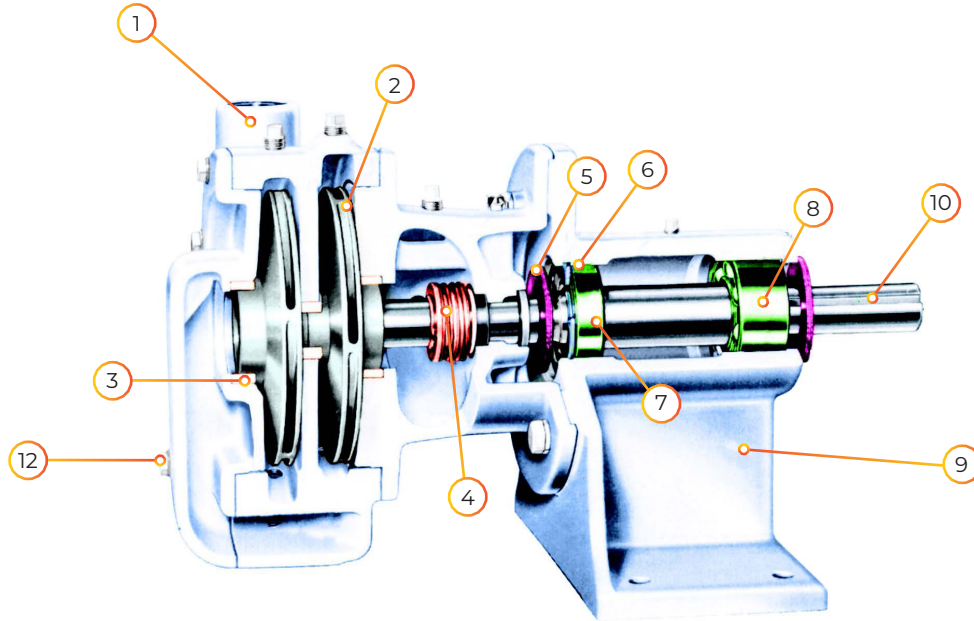

1) VOLUTE CASE

- Versatile (8) position discharge orientation for convenient adaptation to your piping requirements. 1-1/2" NPT discharge. Cast iron case with 400 series stainless steel or brass wear ring options.

2) IMPELLERS

- Opposing dual enclosed impellers for high pressure performance. Opposing design offsets thrust and minimizes bearing loading. Dynamically balanced for smooth, vibration-free operation. We offer impellers in both 300 series stainless steel or brass.

3) WEAR RINGS

- (3) Bronze, 400 series stainless steel, or Brass wear rings, (2) for impeller inlets, (1) common bushing for impeller heads. Maintains peak pump operating performance. Our wear ring options are easily replaceable and eliminate wear to casting.

4) MECHANICAL SHAFT SEAL

- Durable, chemical and grit resistant silicon carbide faces, viton elastomer and stainless steel parts. Located on inlet (low pressure) side of pump, allowing for maximum 80 psi inlet pressure.

5) SLINGERS

- Rubber slingers shield bearings from moisture, dirt and other impurities.

6) SNAP RING

- Holds bearing and shaft assembly in place, preventing axial movement.

7) SHAFT BEARING

- Heavy-duty ball bearing, regreasable, greased during assembly. Bearing sealed on outboard side.

8) * NEW & IMPROVED SHAFT BEARING

- DOUBLE-ROW, HEAVY-DUTY ball bearing, regreasable, greased during assembly. Bearing sealed on outboard side.

9) BEARING BRACKET

- Heavy-duty cast iron bracket holds (2) shaft ball bearings in exact alignment, keeping shaft and impeller assembly running quiet and vibration-free. Bracket provides rigid support for pump end.

10) PUMP SHAFT

- Corrosion-resistant stainless steel provides long life in many applications.

11) DRAIN PLUGS

- Conveniently located, allowing (8) position discharge orientation and always providing for liquid draining capabilities.

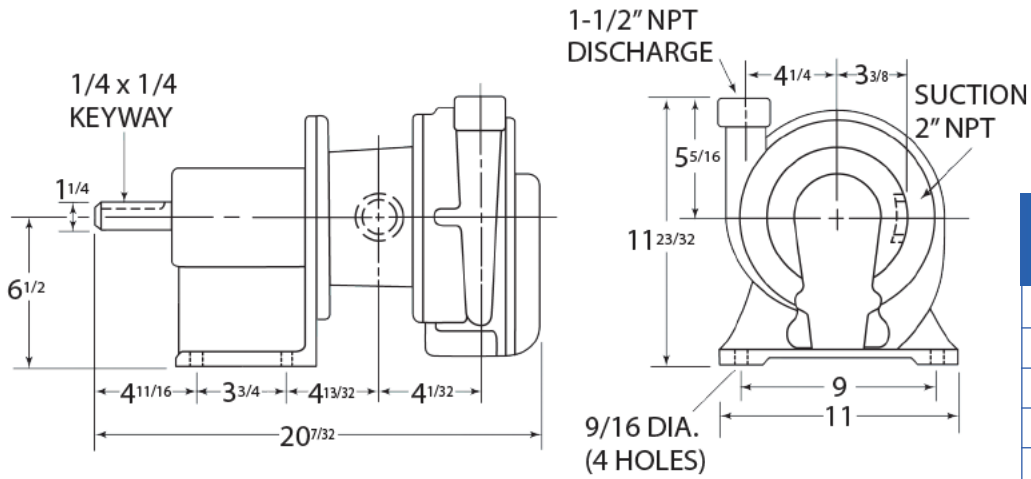

BASIC PUMPS

CATALOG NO.	STANDARD IMPELLER DIA.	APPROX. SHIP WT. LBS.
KI-TSC-5	4 3/4"	130
KI-TSC-7	5 1/4"	130
KI-TSC-10	5 3/4"	130
KI-TSC-15	6 1/2"	130
KI-TSC-20	7"	130

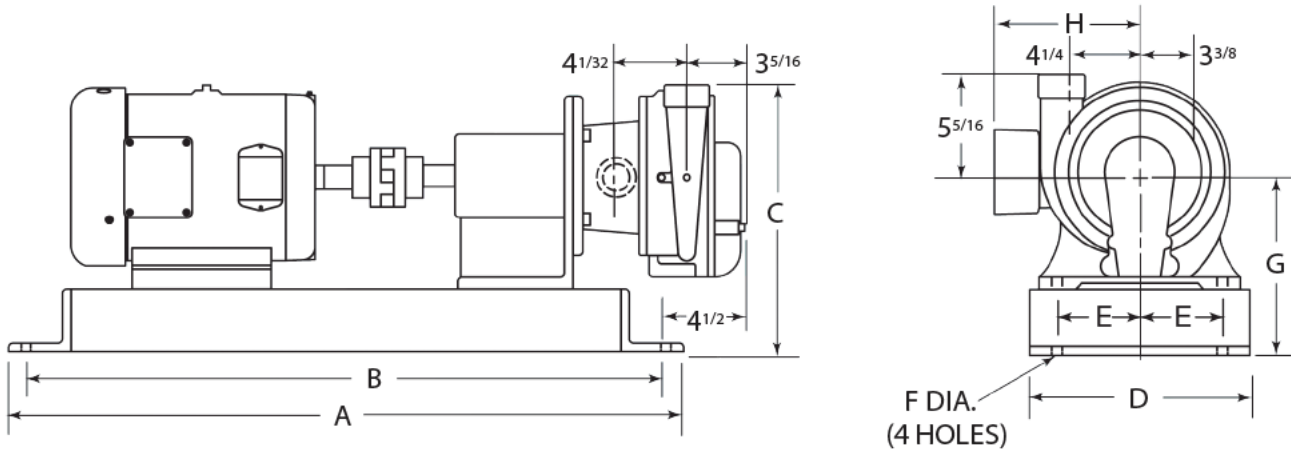

CATALOG NO.	PUMP MOTOR HP	MOTOR FRAME	PUMP SHAFT DIA.	MOTOR SHAFT DIA.	MOTOR SHAFT DIA.									APPROX. SHIP WT. LBS.
					A	B	C	D	E	F	G	H	I	
KI-TSC-5P	5	184T	1 1/4	1 1/8	37	35	14 13/16	12	5	5/8	9 1/2	8 1/16	14 13/16	365
KI-TSC-5P	7 1/2	213T	1 1/4	1 1/8	37	35	14 13/16	12	5	5/8	9 1/2	8 1/16	14 13/16	375
KI-TSC-5P	10	215T	1 1/4	1 3/8	42	40	15 5/16	15	6 1/2	1 1/16	10	8 7/8	15 5/16	410
KI-TSC-5P	15	254T	1 1/4	1 3/8	42	40	15 5/16	15	6 1/2	1 1/16	10	8 7/8	15 5/16	450
KI-TSC-5P	20	256T	1 1/4	1 3/8	42	40	15 5/16	15	6 1/2	1 1/16	10	9 1/16	15 5/16	510

KEEN PUMP is dedicated to producing a quality product, delivered on time, backed by reliable service, at a reasonable price. We back up our product with the BEST warranty. KEEN PUMP knows HIGH PRESSURE PUMPS!

HIGH HEAD PERFORMANCE

- 510 feet (220 psi) @

RUGGED CONSTRUCTION

- High Tensile Strength Cast Iron Castings
- 300 Series Stainless Steel or Brass Impeller Options
- 400 Series Stainless Steel, Brass, or Bronze Wear Ring Options

VERSATILE CONSTRUCTION OPTIONS

- Pump End Only (1-1/4" Keyed Shaft End)

VALUE

- Immediately Available for Quick Shipment
- Priced to Save You Money

APPLICATIONS

- Agricultural
- Spraying
- Car Wash
- OEM Deicing
- Equipment
- Booster Service

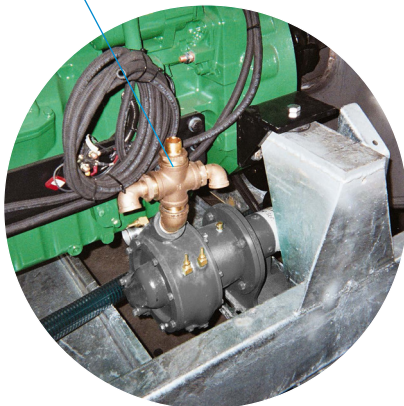
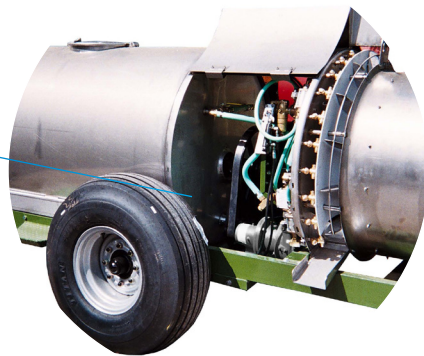

VARIABLE RPM • 7" IMPELLER • 2" SUCTION • 1-1/2" DISCHARGE

3450 RPM • IMPELLER AS NOTED • 2" SUCTION • 1-1/2" DISCHARGE

