



K6CHB

6" Submersible, Heavy Duty Chopper Pump
(Class 1, Div. 1, Groups C & D Hazardous Location)

RUGGED, TOUGH, ABRASIVE RESISTANT
CONSTRUCTION!

HARDENED IMPELLER

- Heat Treated Cast 440C SST, Semi-Open
- Handles The Toughest Materials, Cuts into Pieces
- Works Efficiently with Stationary Cutter Bar

HARDENED CUTTER BAR

- Heat Treated Tool Steel, 60 Rockwell C Hardness
- Easily Adjustable To Maintain Optimal Chopping Performance

RETAINING PLATE

- Retains and Adjusts Cutter Bar According to Specific Field Conditions

BEST MOTOR CONSTRUCTION

- Class "N" (392 F) Highest Temperature Motor Will Not Overheat In Continuous Applications

MOTOR GROUND RING PROTECTION

- Allows Motor to Operate with VFD Without Damaging Bearings and Motor
- Ground Ring Safely Diverts Harmful Voltages Away From Bearings

OIL SUBMERSIBLE BEARINGS

- Heavy Duty Bearings Handle The Toughest Applications of High Pressure and Flow Rates
- Angular Contact Bearings

CAPABILITIES:

- Flows to 2100 GPM
- Heads to 155 Feet
- HP Range 15-60 HP
- Voltage/Phase Options 208/230/460, 3 Phase
- Discharge Connections 4" ANSI 125 Horizontal Flange
- Motor Speeds 1750 RPM
- Impeller Balanced, Semi-Open, 3-Vane
- 3rd Party Approval FM 3615, Class 1, Div. 1, Groups C & D

1. WATERTIGHT CABLE ENTRANCE

Agency-approved, watertight strain relief cord grips with compression grommets protects outer cord jacket. Epoxy-filled inner cord cap provides anti-wicking moisture protection to the motor even if power cable is cut or damaged. 40' UL power & control cords. Additional sealing accomplished by wire terminal plate, separating cord cap from motor housing.

2. MODULAR PUMP DESIGN

Commonality of parts across the Keen product line minimizes the amount of parts required for servicing. Heavy-duty ASTM A48, Class 35 cast iron components.

3. STRONG MOTOR

Powerful high-torque motor for strong pumping. 208/230/460/575 Volt, 3-phase. Slip-Fit stator efficiently transfers heat to cast housing. Class N construction with overload protection in oil-filled chamber for cool operation and long motor life Inverter-duty capable, for VFD / soft start operation.

3A. OIL

Proprietary Keen oil ensures industry-low operating temperatures.

4. SOLID BEARING SUPPORT

Two-bearing design featuring high load-rated angular contact bearings for 100,000 hour B-10 life.

5. SEVERE DUTY DUAL MECHANICAL SEALS

Provide twice the moisture and grit protection for the motor. Upper seal silicon carbide; * Patented Lower seal System. Tungsten carbide seal handles sand, grit and abrasive materials.

6. MOISTURE DETECTION

Seal leak probe signals alarm in control panel for scheduled maintenance.

7. HYDRAULIC DESIGN

Semi-Open, 440C Stainless Steel, Heat Treated Impeller. Features backside pump-out vanes, keeping the lower seal clean. Dynamically balances for smooth, quiet operation and long bearing life.

8. STANDARD FLANGE CONNECTION

4" Horizontal, Class 125 ANSI discharge flange. Industry standard, 8-bolt pattern, Ductile Iron Casing.

9. HIGH PERFORMANCE CHOPPER

Engineered cutter bar ideally suited for chopping all wastewater solids. Bar is field-adjustable and is made of T1 tool steel, heat-treated to minimum 60 Rockwell C hardness. Easily serviceable and replaceable.

10. CHOPPER RETAINING PLATE

Retains and adjusts cutter bar according to field conditions.

K6CHB

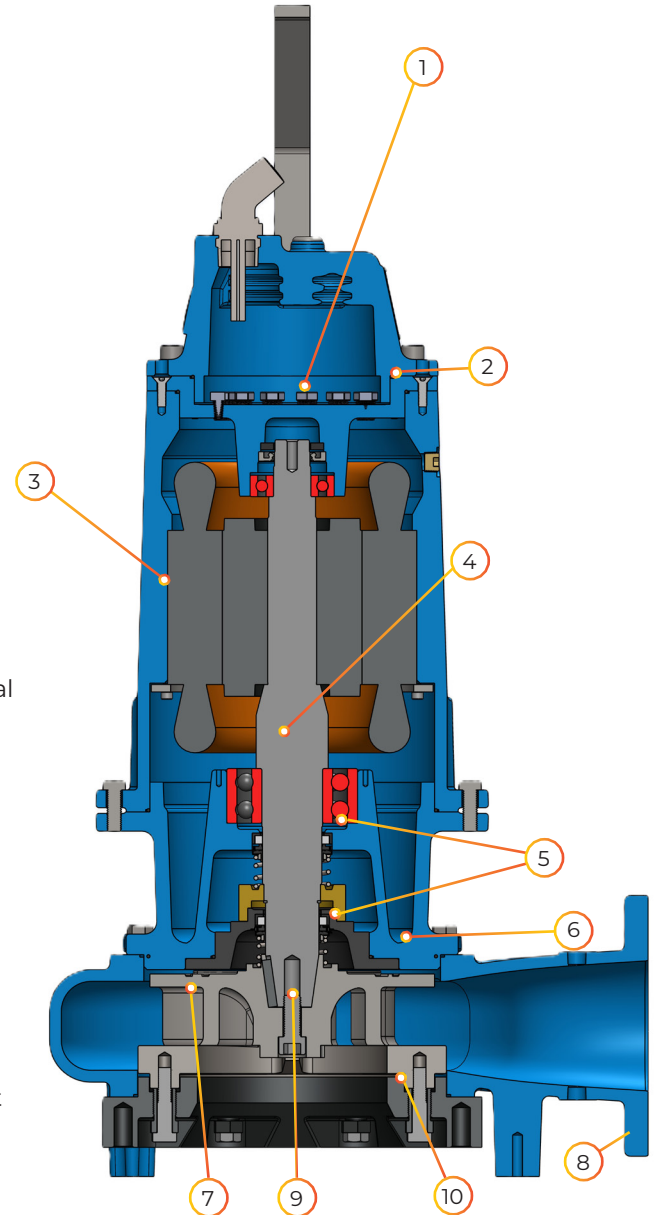



PUMP SERIES		K6CHB		6" SUBMERSIBLE SEWAGE PUMPS	
Speed	1750 RPM	Discharge	6"		

GPM: _____ TDH: _____

Performance

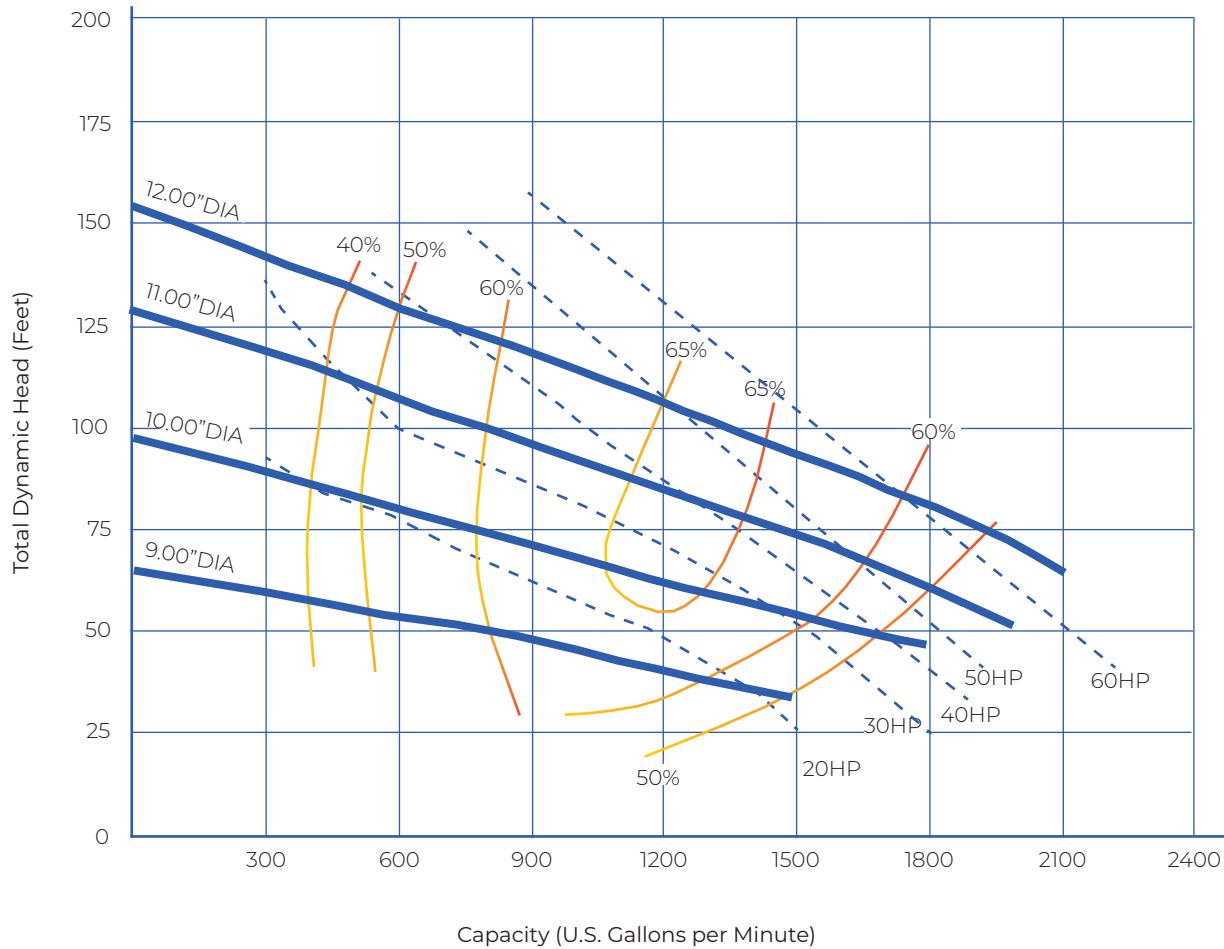

The curves reflect maximum performance characteristics without exceeding full load. Operation is recommended in the bounded area with operational point within the curve limit. Performance curves are based on actual tests with clear water at 70° F and 1280 feet site elevation.

PHYSICAL DATA	
Discharge Size	ANSI 6" Horizontal
Impeller Type	Semi-Open three vane design
Power/Control Cable Length	40' Standard
Paint	Blue, Powder Coated - Inside Volute - Ceramic Coated For Abrasion Resistance
MOTOR CONSTRUCTION	
Motor Type	Enclosed Submersible Oil Filled
NEMA Insulation Code	Class N
Service Factor	1.2
NEMA Design Type	B (3 ϕ)
Motor Protection	Thermal Sensors Embedded in the Windings
Maximum Stator Temperature	Class N: 392° F (200° C)
Power Cord Type	SOOW-600V, 90° C , TYPE W - 2000V, 90 C
Control Cord Type	SOOW - 600V, 90° C
MATERIALS OF CONSTRUCTION	
Cord Entry	Cast Iron, ASTM A48, Class 35
Motor Housing	Cast Iron, ASTM A48, Class 35
Bearing Housing	Cast Iron, ASTM A48, Class 35
Volute	Cast Iron, ASTM A48, Class 35 / Ceramic Coated Inside
Impeller	440C SST, Hardened
Wear Ring	Bronze, CDA 836
Shaft	ANSI 400 Stainless Steel
Inboard Mechanical Seal	Silicone Carbide / Silicone Carbide / Viton Elastomers
Outboard Mechanical Seal	Silicone Carbide / Silicone Carbide / Viton Elastomers
Fasteners	ANSI 18-8 Stainless Steel
O-Rings	fluorocarbon Rubber
Upper Bearing	Conrad Style Single Row Deep Groove Ball Bearing
Lower Bearing	Conrad Style Double Row Angular Contact Ball Bearing
Labryinth Seal	Bronze, CDA 836
Chopper Impeller	440C SST, Heat Treated
Cutter Bar	Tool Steel, Heat Treated



THERMAL DATA	
Maximum Liquid	140° F (60° C)
Maximum Stator	311° F (155° C)
Heat Sensor	Open: 257° F (125° C) Max. / 239° F (115° C) Min.
	Closed: 194° F (90° C) Max. / 119° F (48° C) Min.
Oil Flash Point	390° F (199° C)

ELECTRICAL DATA				
RPM	1750			
Electrical Ratings	Heat Sensor	24VDC, 5AMPS	115VAC, 5AMPS	230VAC, 5AMPS
	Seal Fail	300VAC 5mAMPS		
Voltage Tolerance	± 10%			



HP	VOLTS	PHASE	NEC CODE	SERVICE FACTOR	FULL LOAD AMPS	SF AMPS	LOCKED ROTOR AMPS	RUN KW	START KVA	RUN KVA
15	208	3	H	1.2	53.8	64.6	277.2	16.5	99.7	18.3
	230				48.9	58.7	249.7			
	460				24.5	29.4	124.9			
	575				19.6	23.5	99.9			
20	208	3	E	1.2	69.3	83.2	277.2	22.4	99.7	25.0
	230				62.4	74.9	249.7			
	460				31.2	37.5	124.9			
	575				25.0	30.0	99.9			
25	208	3	G	1.2	78.5	94.2	417.6	25.5	150.3	28.3
	230				70.7	84.9	376.2			
	460				35.4	42.4	188.1			
	575				28.3	33.9	150.5			
30	208	3	F	1.2	104.4	125.3	417.6	33.8	150.3	37.6
	230				94.1	112.9	376.2			
	460				47.0	56.4	188.1			
	575				37.6	45.1	150.5			
40	208	3	E	1.2	135.6	162.7	542.4	43.9	195.1	48.8
	230				122.2	146.6	488.6			
	460				61.1	73.3	244.3			
	575				48.9	58.6	195.5			
50	230	3	D	1.2	135.2	162.3	540.9	48.6	215.8	54.0
	460				67.6	81.1	270.5			
	575				54.1	64.9	216.4			
60	460	3	C	1.0	81.1	81.1	270.5	58.2	215.8	64.6

MOTOR EFFICIENCIES & POWER FACTOR									
HP	PHASE	MOTOR EFFICIENCY %				POWER FACTOR %			
		SERVICE FACTOR LOAD	100% LOAD	75% LOAD	50% LOAD	SERVICE FACTOR LOAD	100% LOAD	75% LOAD	50% LOAD
15	3	91	90	88	82	86	85	81	74
20	3	91	90	88	83	86	85	81	74
25	3	92	91	89	83	87	86	82	74
30	3	92	91	89	83	87	86	82	74
40	3	93	92	89	84	88	86	83	74
50	3	93	92	89	84	88	86	83	74
60	3	93	92	89	84	89	87	84	74



1.0 SCOPE

- This specification details the mechanical and electrical requirements for squirrel-cage, induction motors, three-phase, designed for wet well and dry well submersible pump applications in water and sewage.
- The intent of this specification is to define submersible premium quality pumps which will provide efficient operation with high mechanical integrity under adverse operating conditions for maximum life and minimum life cycle costs.
- This specification covers sewage wet well and dry well applications defined by the National Electrical Code (NEC®) as class 1, Division 1, hazardous locations section 501-8(a) requiring explosion-proof construction.

2.0 SUBMERSIBLE MOTOR CONSTRUCTION

- All castings in the stator housing construction shall be ASTM A48 Gray Cast Iron Class 35.
- The submersible motor stator and rotor shall be of an induction type, NEMA® B (Three-Phase) squirrel cage design.
- The stator is to be slip-fit in watertight oil-filled, TENV chamber to provide the maximum heat dissipation.
- The armature assembly of the motor must meet or exceed the balance specification as defined in ISO 1940 G2.5.
- Stator housing shall be filled with clean, high dielectric oil that lubricates bearings and seals, transferring heat from windings and rotor to the outer cast housing. Proprietary Keen oil ensures industry-low operating temperatures.
- Submersible motor design:
 - _____ Horsepower
 - _____ RPM
 - _____ Voltage
 - _____ Phase
 - _____ Frequency
 - 1.20 Service Factor
- Insulation system of the submersible motor design shall be of Class H as defined in NEMA® MG-1 and established in accordance with IEEE® std. 1 rated for 392° F (200°C). To include:
 - The stator windings shall be constructed of material to meet the Class N insulation system.
 - The insulation varnish in the system must be applied in a dip and bake manner.
 - Stator lead material must meet or exceed Class N insulation system.
 - Thermal limiting device shall be designed, secured to the stator and constructed to meet the Class F insulation system.
 - The thermal limiting devices shall be attached to each phase winding.
 - The thermal limiting devices shall be used in conjunction with and supplemental to external motor overload protection and must be connected to the motor control center.
- Operation of the motor shall be designed for:
 - Handling pumped media of 140° F (60° C) ambient.
 - Capable of 15 evenly spaced starts per hour.
 - A combined service factor, in combination with effect of voltage, frequency and specific gravity, shall be at a minimum of 1.20.
 - Acceptable voltage variation is +/- 10%.
 - Acceptable frequency variation is +/- 5%

- Voltage unbalance must not exceed 1% as defined per NEMA M6-112.45.
- Current unbalance must not exceed 5%.
- The horsepower of the motor shall be adequately designed to be nonoverloading across the entire pump performance curve, to include pump shutoff and pump run-out.
- All bolted connections in the submersible motor construction shall be:
 - Secured with 304 stainless steel fasteners.
 - Secured joints in the construction shall be compression fitted with fluorocarbon o-rings.
- The submersible motor and pump must be designed, constructed and assembled by the same manufacturer.

3.0 SUBMERSIBLE MOTOR CORD ENTRY CONSTRUCTION

- The cord entry housing shall be ASTM® A48 Gray Cast Iron Class 35.
- Power and control cables shall be secured and sealed to the submersible motor. Construction shall be of a method to provide anti-wicking barriers to the submersible motor.
 - The outer jacket of the power and control cables shall be sealed with an agency-approved, watertight strain relief cord grip fitted with a nitrile compression grommet.
 - The connections between the power cable and the stator leads and control cable and the internal motor control leads shall be potted and encapsulated in a two-part epoxy in the cord entry system.
 - Additional sealing is provided by pump terminal plate, which separates cord cap from motor housing, by PBT encapsulated terminal studs.
- All bolted connections in the cord entry construction shall be:
 - Secured with 304 stainless steel fasteners.
 - Secured joints in the construction shall be compression fitted with fluorocarbon o-rings.
- The power and control cables shall be recognized by Underwriters Laboratory® (UL) & Canadian Standard Association® (CSA) and will be delivered in a standard length of 40 foot.
- The cord entry housing shall be fitted with a stainless steel lifting bale sized and of adequate design to securely lift the complete construction of the submersible pump.
- The power and control cables shall be jacketed in a material suitable for submersion, oil resistant, and be flexible for portable installation.
- Cable sizing shall be in accordance to NEC® specifications.

4.0 MECHANICAL SEALS

- Each pump shall be constructed with a tandem mechanical shaft seal system incorporating two independent shaft seal assemblies.
- Seals shall operate in a lubricant reservoir that hydro-dynamically lubricates the seal faces at a constant rate.
- Inboard and outboard seal construction shall be of the following material:
 - Primary stationary ring shall be constructed of silicon carbide face material.
 - Primary rotating ring shall be constructed of silicon carbide face material.
 - Elastomers shall be constructed of Viton®.
 - Metal components shall be constructed of stainless steel for corrosion resistance.
- The inboard shall be hydro-dynamically lubricated and operated in a sealed oil reservoir.
- The inboard seal chamber seal shall be designed and constructed to prevent lubricant over filling and provide adequate lubricant expansion to avoid overpressuring of the seal.
- The pump shall be capable of operating in the clockwise or counter clockwise direction without damaging the seal faces.
- The pump shall be capable of operating in a dry environment without damage to the seal faces.
- Class 1, Division 1, explosion-proof models will be included with an additional labyrinth seal constructed of bronze, CDA836 material, and is mounted directly above the pump seal plate to take radial loads and act as a flame path for seal chamber.



5.0 PUMP BEARINGS

- Bearings shall be designed to an ABEC® System 1 or better.
- Each pump shall be constructed with a two-bearing system design.
 - The upper bearing shall be a Conrad type, single ball row, Angular Contact deep groove ball bearing designed to adequately handle the required radial loads.
 - The lower bearing shall be a Conrad type, double row, angular contact ball bearing designed to adequately compensate for the axial loads and radial forces.
- The bearings shall be designed to deliver a minimum B-10 bearing life of 100,000 hours when operation is within the limitations of the manufacturer's performance curve.
- Bearings shall be protected from VFD controllers with AEGIS® grounding ring.

6.0 PUMP SHAFT

- The pump shaft shall be an extension of the motor shaft. Any other construction that would include coupling of two shafts is not acceptable.
- The pump shaft shall be a Ferritic grade AISI® Type 400 series stainless steel.
 - Pump shaft material crystal structure shall be body centered cubic (bcc).
 - Pump shaft shall be of a ferromagnetic material.

7.0 IMPELLER

- Material shall be 440C, SST, hardened, heat treated. ASTM® A48 gray cast iron shall be unacceptable.
- The design shall be one-piece, semi open, three vane design.
- The impeller shall be designed with pump out vanes on the back shroud of the pump impeller to prevent the pump media from entering the outboard seal cavity.
- The impeller shall be keyed to the pump shaft and retained with a bolt and washer.
 - All wetted fasteners shall be of a corrosion restraint stainless steel material.
- The mass moment of inertia calculations shall be provided by the pump manufacturer upon request.
- Pump impeller shall be ceramic coated.
- Pump impeller shall be ceramic coated. Ceramic coating must be a two component, 100% solids liquid polymer composite for surface application and coating component parts. Two coat process must be applied for best erosion and corrosion resistance including higher temperature application.

8.0 VOLUTE CASE

- Material shall be ASTM® A48 class 35, gray cast iron.
- Design shall be a single piece and a modified constant velocity.
- Constructed of smooth passage ways large enough any solid that can enter the impeller.
- The discharge is to be of a horizontal centerline configuration.
- The discharge is to be 6" ANSI® standard Class 125, 8-bolt configuration..
- The inside of volute case shall be ceramic coated. Ceramic coating must be a two component, 100% solids liquid polymer composite for surface application and coating component parts. Two coat process must be applied for best erosion and corrosion resistance including higher temperature application.

9.0 CUTTER BAR

- Heat treated tool steel, 60 Rockwell C hardness.
- Adjustable feature to maintain clearances.

PUMP SERIES

K6CHB

6" SUBMERSIBLE SEWAGE PUMPS

DIMENSIONAL DATA

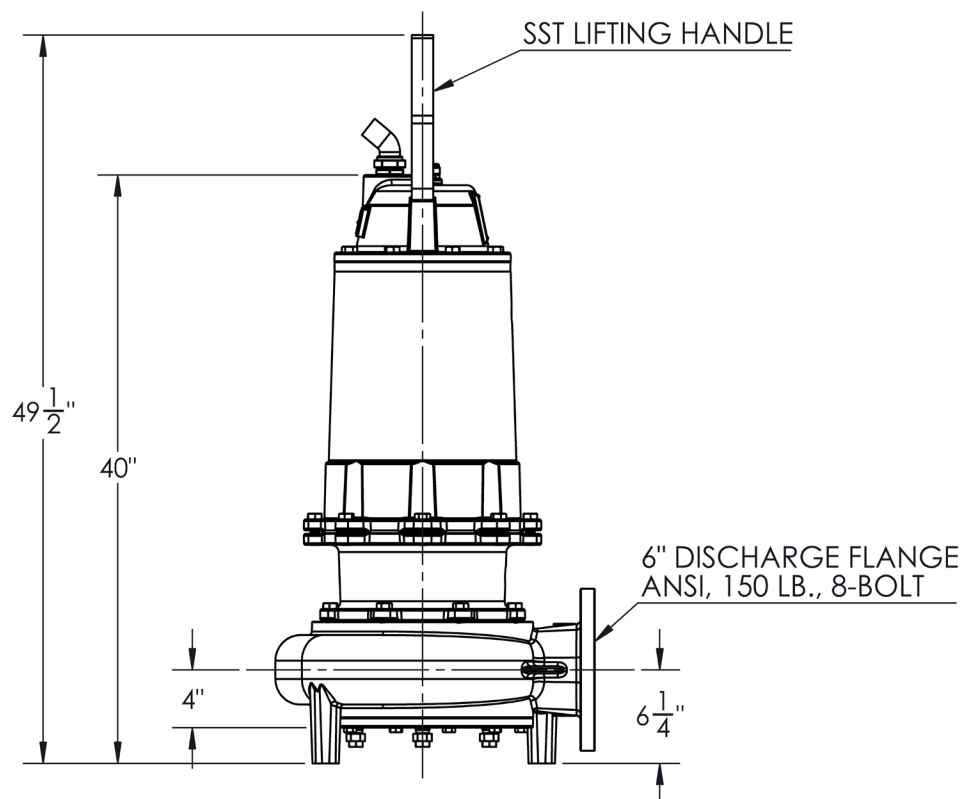
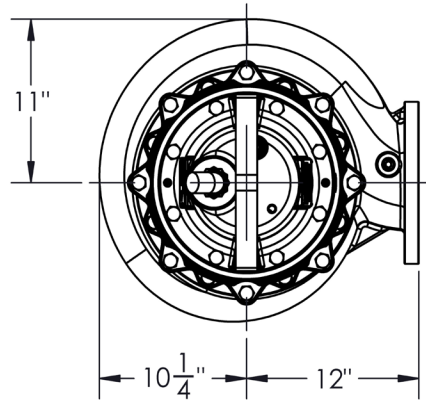



NOTES:

- 1. ALL DIMENSIONS IN INCHES UNLESS NOTED.
- 2. PUMP SHOWN 1150 & 1750 RPM.
- 3. DISCHARGE FLANGE ANSI CLASS 125 UNLESS NOTED.
- 4. ABSOLUTE MINIMUM AND RECOMMENDED MINIMUM SUBMERGENCE LEVELS NOTED.
- 5. DISCHARGE BASE ELBOW MUST BE PLACED ABOVE SUMP BOTTOM AS NOTED.
- 6. DIMENSIONS MAY VARY DUE TO NORMAL MANUFACTURING TOLERANCES.
- 7. IF DISCHARGE PIPE IS LARGER THAN DISCHARGE ELBOW, ECCENTRIC REDUCER MUST BE USED LIMITED TO 2X LARGER MAXIMUM.

ABSOLUTE MINIMUM SUBMERGENCE LEVEL:
22" FROM BOTTOM

RECOMMENDED MINIMUM SUBMERGENCE LEVEL:
40" FROM BOTTOM

