



“Radial”Cutter
(STANDARD)



“Slicer”
(OPTION)

SKG2

2HP Dual Seal Grinder Pump

POWERFUL

- Pressures to 47 psi (108 feet)
- Flows to 50 GPM
- High Torque Motor

RELIABLE

- Hardened Stainless Steel Cutter
- Dual Silicon Carbide Seals
- Class 35 Cast Iron Casing with Durable Powder Coat Finish

CONSTRUCTION

- Stainless Steel Lift Handle
- Lightweight, Only 72 pounds
- Stainless Steel Stand
- 30 foot Power Cord



REV 01/2024



1. WATERTIGHT CABLE ENTRANCE

Agency-approved, watertight strain relief cord grip with compression grommet protects outer cord jacket. Epoxy-filled inner cord cap provides anti-wicking moisture protection to the motor even if powercable is cut or damaged. Stainless steel cord grip.

2. MODULAR PUMP DESIGN

Commonality of parts across the Keen product line minimizes the amount of parts required for servicing. Heavy-duty ASTM A48, Class 35 cast iron components.

3. STRONG MOTOR

Powerful high-torque motor for reliable pump operation. Pressed stator securely holds motor and efficiently transfers heat. Class F insulation with overload protection in oil-filled chamber for cool operation and long motor life.

4. 2-BEARING SUPPORT

Motor / Pump shaft securely held with upper and lower ball bearing plus additional sleeve bearing in lower seal chamber. Long 100,000 hour B-10 bearing life.

5. DOUBLE MECHANICAL SEAL PROTECTION

Dual silicon carbide mechanical shaft seals provide twice the moisture protection for the motor. Dual seals are housed in a secondary oil-filled seal chamber. Tougher silicon carbide seals better handle sand, grit and abrasive materials.

7. NON-OVERLOADING HYDRAULIC DESIGN

The recessed centrifugal impeller allows 100% performance curve operation from shut-off to maximum flow without damage to the pump or system. The recessed vortex impeller is out of the passageway of fluid flow, eliminating concerns of blockage or wear.

8. PROVEN GRINDER ASSEMBLY

Hardened (Rockwell 56-60) stainless steel grinder assembly has 30+ years proven field experience. The reversible grinder ring and grinder impeller effectively reduce solids into a fine slurry, easily passable in a piping system without concerns of clogging. Highly efficient 16,600 cuts/second.

9. EASY PIPING CONNECTION

Removable 1-1/4" NPT connection flange for simple and easy connection to discharge piping.

10. ACCESSORIES

Stainless steel lifting handle included. Anti-Vibration mounting feet OPTIONAL..

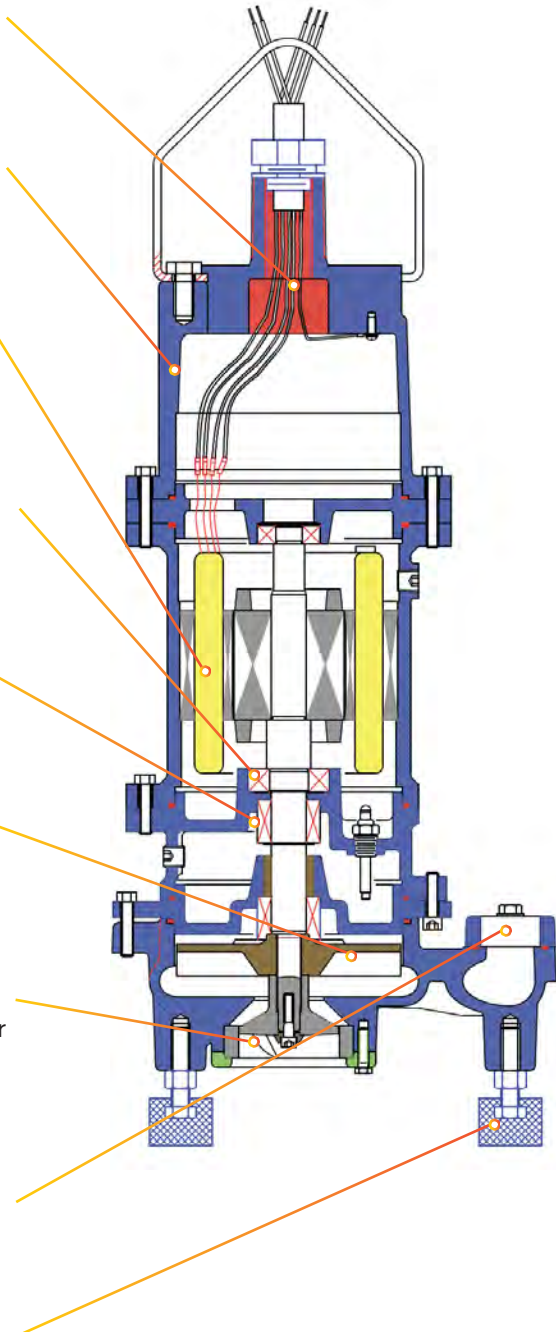

2HP SUBMERSIBLE GRINDER PUMP

GENERAL		MOTOR DATA	
Pump Model	SKG2	HP / Power Supply	2HP / 1 ϕ , 60 Hz
		Full Load Amps 208V	15.5 Amps
PUMP DATA		Start Amps 208V	72 Amps
Date	09/2022	Start / Run Amps 240V	14.5 Amps
Discharge Flange	1-1/4" NPT, Vertical	Poles / Rated Speed	2 P / 3450 rpm
Grinder Ring	26 Slots	Insulation Class	N Class
Impeller Type	Recessed	Start Capacitor	216 ufd, 250 VAC
SINGLE PHASE	START KIT SK-2A includes: Start & Run Capacitors, Relay, and Mounting Hardware	Run Capacitor	25 ufd, 370 VAC

PERFORMANCE CURVE

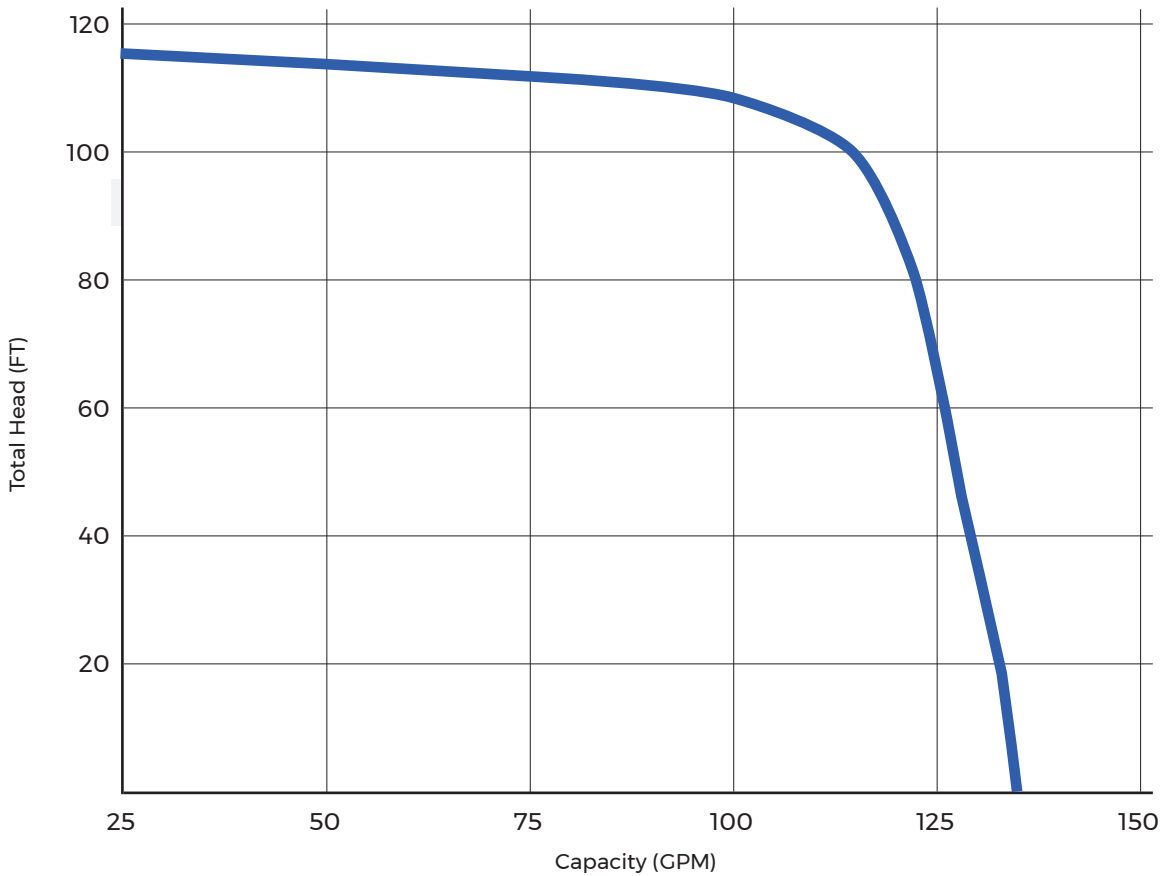

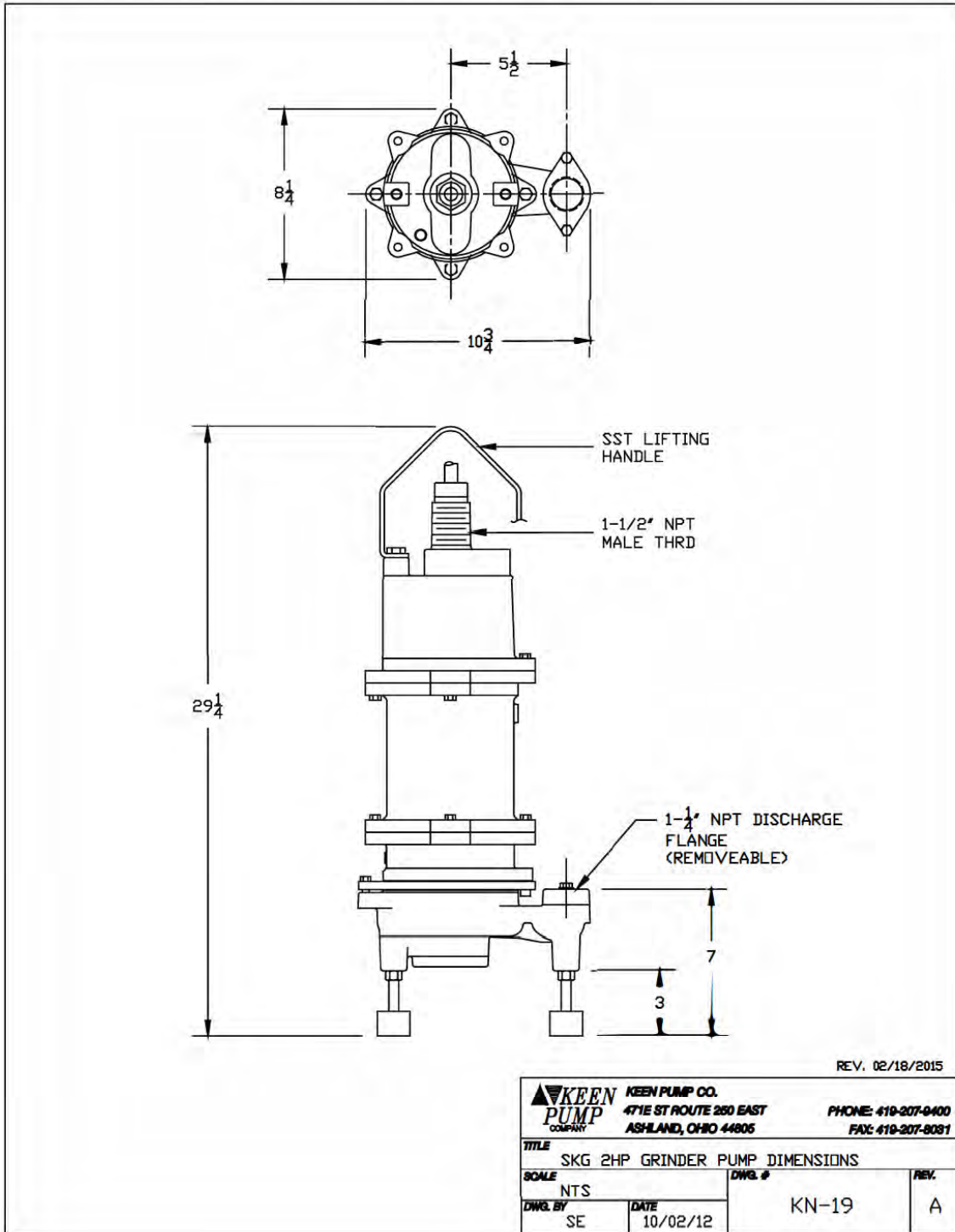

2 HP GRINDER PUMPS

MODEL NO. SKG2

PUMP MODEL – Pump shall be of the centrifugal type, SKG2 with an integrally built-in grinder unit and submersible type motor.

OPERATING CONDITIONS – The pump shall have a non-overloading maximum capacity of ___ GPM, a maximum total dynamic head of ___ feet, and shall use a motor rated at 2 HP and 3450 RPM. The grinder unit shall be capable of macerating all material in typical domestic and commercial sewage, including reasonable amounts of foreign objects such as sanitary napkins, disposable diapers, thin rubber, sanitary wipes, floor pads, small wood, plastic and the like to fine slurry that will easily pass through the pump and 1-1/4" NPT discharge.

CONSTRUCTION – Major pump components shall be of gray cast iron, ASTM A-48, Class 35, with smooth surfaces devoid of blowholes or other irregularities. All exposed nuts or bolts shall be 304 stainless steel. All metal surfaces coming into contact with the pumpage, other than stainless steel, shall be protected by a factory applied powder coat paint finish to the exterior of the pump.

Sealing design shall incorporate metal-to-metal contact between machined surfaces. Critical mating surfaces where watertight sealing is required shall be machined and fitted with O-rings. Fittings will be the result of controlled compression of rubber O-rings in two planes and O-ring contact of four sides (rabbet joint construction) without the requirement of a specific torque limit. No secondary sealing compounds, elliptical O-rings, grease, or other devices shall be used.

PUMP IMPELLER – Pump impeller shall be ductile iron and threaded onto a stainless steel shaft. The impeller shall be of the recessed vortex type to provide an unobstructed passage through the volute for the ground solids. Impeller must be dynamically balanced to specification ISO 1940G 6.3 standard.

RADIAL CUTTER GRINDER CONSTRUCTION – Provided as a proven cutting method, both grinder impeller and shredding ring shall be of 440 stainless steel hardened to 58-60 Rockwell C. The grinder assembly shall consist of a grinder impeller and shredding ring mounted directly below the volute passage. The grinder impeller is threaded to a stainless steel shaft, locked with a stainless steel screw and washer. The shredding ring shall be secured by a retaining ring which is bolted into the cast iron volute for easy removal. All grinding of solids shall be from the action of the grinder impeller against the shredding ring. There shall be 24,000 cuts / second.

OPTIONAL: SLICER GRINDER CONSTRUCTION – Maceration is accomplished by a combination of a rotary slicer and stationary slicer plate. Rotary slicer shall consist of (3) blades which protrude away from the inlet. Rotary slicer shall be bolted to shaft within close tolerance of grinding slicer plate. The stationary slicer plate shall consist of engineered-shaped holes for optimum cutting of debris. A slicer plate shall contain grooved slots to eject pump media away from underside of rotary cutter. Slicer plate shall be fastened with countersunk head screws that are flush with surface of plate. Pumps with protruded or exposed head fasteners shall be considered not equal. Both rotary slicer and slicer plate shall be 440C stainless steel hardened to 58-60 Rockwell C.



SEALS - Type 21, domestic manufactured, dual mechanical seal construction mounted in tandem, shall protect the motor. Standard construction of primary seal shall be silicon / carbide with Viton® elastomers. Standard construction of secondary seal shall be silicon / carbide with Viton® elastomers. The seal face shall be lapped to a flatness of one light band. Water in the chamber shall cause a red light to turn on at the control box. This signal shall not stop the motor, but shall act as a warning only, indicating service is required. Lip seal arrangements shall not be considered equal.

MOTOR - The pump motor construction shall be per NEMA MG-1 1.15 standard and shall be of the submersible type, rated 2 HP, 3450 RPM. The motor shall be for 60 Hz, 208, or 240 volt, single-phase operation. Three-phase operation shall be 208, 230 or 460 volt. Single-phase motors shall be capacitor start, capacitor run type for high starting torque. Start & run capacitors, and starting switch for operating the motor will be found in the control box. Major motor operating temperature must not exceed Class H ratings.

The stator winding shall be of the open type with Class N insulation. Any other construction shall not be considered equal. The stator shall be pressed into the cast iron motor housing. Winding housing shall be filled with clean, high dielectric oil that lubricates bearings and seals, transferring heat from windings and rotor to the outer cast housing. Maximum skin temperature of motor assembly shall not exceed a T-4 rating per FM3615 standards. Any motor assembly T-code per FM3615 standard that exceeds a T-4 rating shall be considered not equal.

Single-phase motors shall have automatic reset overload protection attached to the top end of the motor windings to stop the motor if the motor winding temperature reaches 130 degrees C. The high temperature shut-off will cause the pump to cease operation, should a control failure cause the pump to run in a dry wet well. The overload shall automatically reset when the motor cools to a safe operating temperature. Three-phase motors contain temperature sensors with (2) two wires for attachment to the control panel.

BEARINGS / SHAFT - The motor shall have two heavy-duty ball bearings and one sleeve bearing to support the pump shaft, taking radial and thrust loadings. Bearings shall be designed to an ABEC® System 1 or better. The upper bearing shall be a Conrad type, single-row, deep groove ball bearing designed to adequately handle the required radial loads. The lower bearing shall be a single-row, deep groove ball bearing designed to adequately compensate for the axial loads and radial forces. Bearings shall be designed to deliver a minimum L-10 bearing life of 100,000 hours when operation is within the limitations of the manufacturer's performance curve. The bearings shall be lubricated in oil and will not require maintenance as described in ANSI/HI 1.4-2010 A.6.

POWER CORD - The motor power cord shall be 12 Ga. Type SOOW, UL listed, CSA approved cable. The cable jacket shall be sealed at the motor entrance by means of an agency-approved rubber compression washer and compression nut. An epoxy-filled cord cap seals the outer cable jacket and individual leads to prevent water from entering the motor housing. Compression fittings with quick disconnect molded pins shall not be considered equal.