

**PATENTED**

"Slicer"



## LCHGS2

Semi-Open Grinder Series  
High Pressure Pump

### HIGH FLOW & HIGH HEAD

- Up to 22 GPM
- Up to 195 Feet Shutoff

### ADVANCED SLICING FOR "FLUSHABLES"

- Wipes, Floor Pads, etc.

### SILICON CARBIDE DUAL SEALS

- Viton® Elastomers

### BEST MOTOR DESIGN

- Motor Pressed into Housing for Superior Heat Transfer
- Long Bearing & Seal Life



**PATENTED**

63/440,977



"Slicer" Cutter  
Preventing Jamming  
on Solids

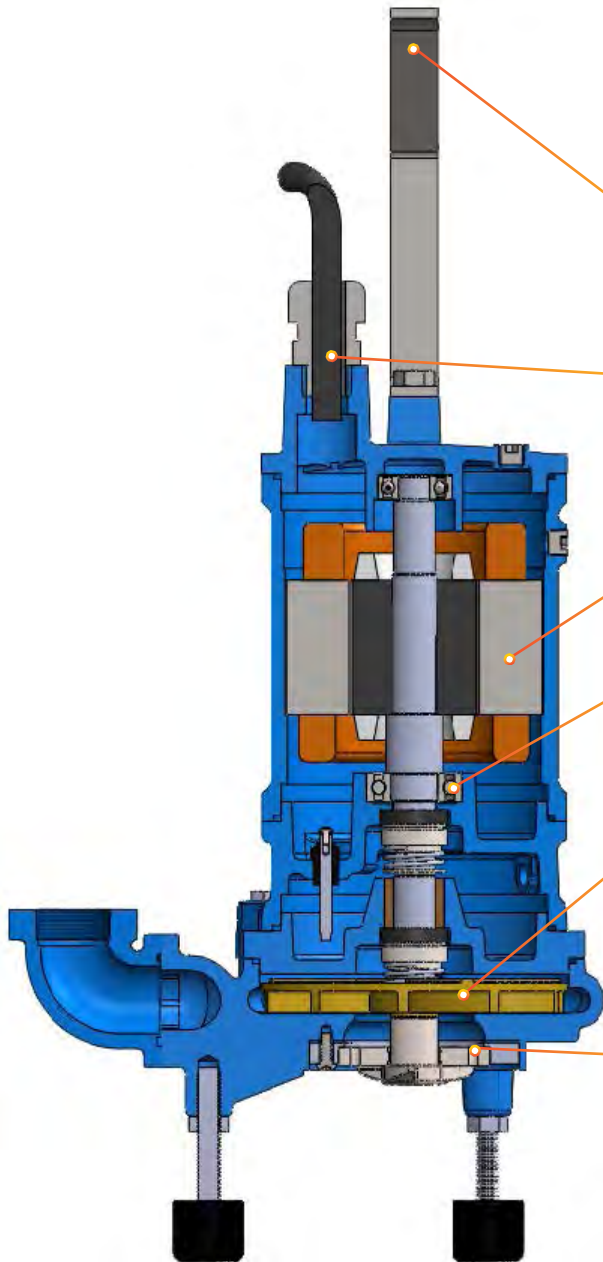

**STAINLESS STEEL LIFT HANDLE**

**EPOXY-POTTED CORD ENTRY**

- Triple-Barrier Moisture Protection

**HIGH-TORQUE MOTOR OIL-COOLED FOR SUPERIOR HEAT DISSIPATION**

**SUPERIOR DUAL MECHANICAL SEALS - SILICON CARBIDE W/ VITON® ELASTOMERS**

**1-STAGE BRONZE IMPELLER**

**ADVANCED CUTTING SYSTEM**

- Highly Efficient Solids-Slicing
- User-Friendly Field Service
- Hardened Stainless Steel

**ADJUSTABLE SLICER ASSEMBLY**

- Maintains Precision Clearances For Optimal Shredding Of Solids
- No Shims

### 2HP SUBMERSIBLE GRINDER PUMP

GENERAL		MOTOR DATA	
Pump Model	<b>LCHGS2</b>	HP / Power Supply	2HP / 1 $\phi$ , 60 Hz
		Full Load Amps 208V	19 Amps
PUMP DATA		Start Amps 240V	17.7 Amps
Date	09/2022		
Discharge Flange	1-1/4" NPT, Horizontal or Vertical		
Grinder Construction	Stainless Steel		
Grinder Hardness	58 - 60 Rockwell		
Impeller Type	Semi - Open	Poles / Rated Speed	2 P / 3450 rpm
SINGLE PHASE/ THREE PHASE	START KIT SK-5 includes: Start & Run Capacitors, Relay, and Mounting Hardware	Insulation Class	N Class
		Start Capacitor	216 ufd, 250 VAC
		Run Capacitor	30 ufd, 370 VAC

### PERFORMANCE CURVE

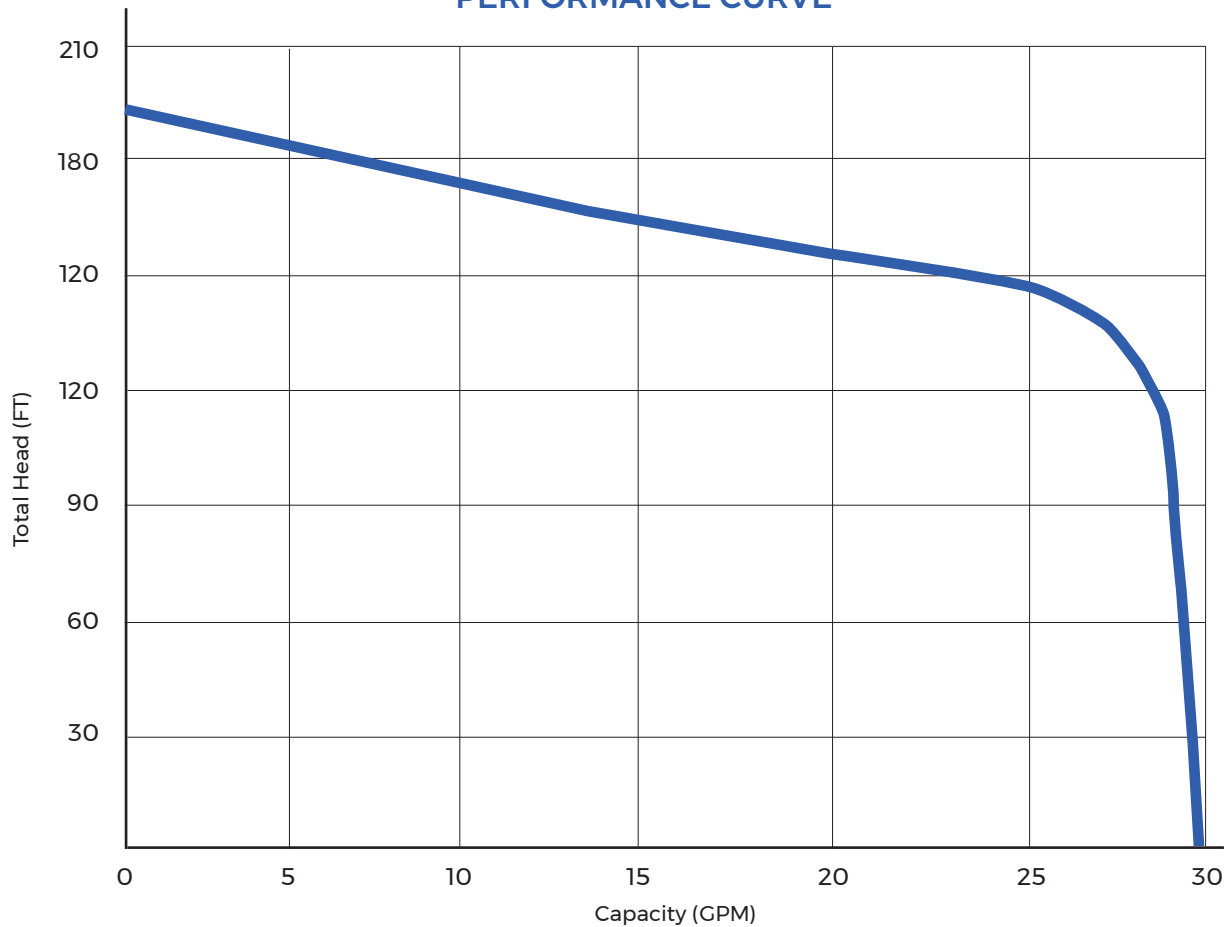

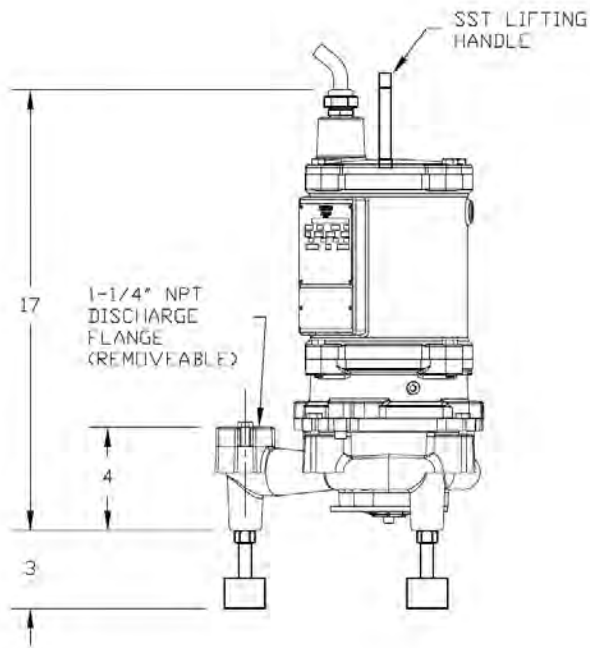
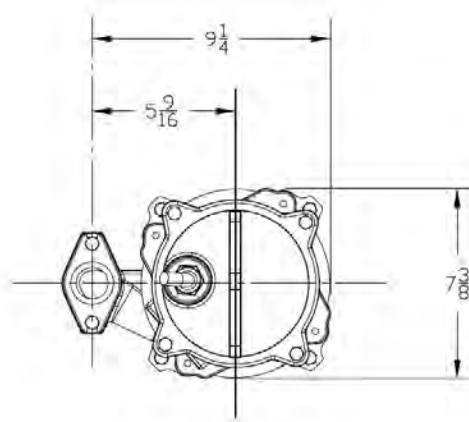

<b>KEEN PUMP COMPANY</b>	KEEN PUMP CO.	PHONE: 419.207.9400
	471 US HWY 250 EAST ASHLAND, OHIO 44805	FAX: 419.207.9031
TITLE LCHSG2 2HP GRINDER PUMP DIMENSTIONS		
SCALE NTS	DWG. # KN-1264	REV.
DWG. BY WS	DATE 05/02/2022	

## PHYSICAL DATA

Discharge Size	1-1/4" NPT
Impeller Type	Balanced, Semi-Open
Power/Control Cable Length	30' Standard
Paint	Blue, Powder Coat Paint Finish

## MOTOR CONSTRUCTION

Motor Type	Enclosed Submersible Oil Filled
NEMA Insulation Code	Class N
Service Factor	1.0
Motor Protection	Thermal Sensors Embedded in the Windings
Maximum Stator Temperature	392°F (200°C)
Power Cord	12-5 SOOW - 600V, 90° C
Std. Third Party Approval	FM3615

## MATERIALS OF CONSTRUCTION

Cord Entry	Cast Iron, ASTM A48, Class 35
Motor Housing	Cast Iron, ASTM A48, Class 35
Bearing Housing	Cast Iron, ASTM A48, Class 35
Volute	Cast Iron, ASTM A48, Class 35
Impeller	(85-5-5-5) Bronze
Shaft	ANSI 400 Stainless Steel
Rotating "Axial" Cutter	440 SST Hardened 58-60 Rockwell C
Stationary "Axial" Cutter	440 SST Hardened 58-60 Rockwell C
Inboard Mechanical Seal	Silicon Carbide / Silicon Carbide, Viton® Elastomers
Outboard Mechanical Seal	Silicon Carbide / Silicon Carbide, Viton® Elastomers
Fasteners	ANSI 18-8 or 304 Stainless Steel
O-Rings	Nitrile Rubber
Upper Bearing	Conrad Style Single Row Deep Groove Ball Bearing 100,000 Hours, L-10
Lower Bearing	Conrad Style Single Row Deep Groove Ball Bearing 100,000 Hours, L-10
Sleeve Bearing	Bronze, Sintered

THERMAL DATA	
Maximum Liquid	140° F (60° C) Intermittent
Maximum Stator	392° F (200° C)
Heat Sensor	Open: 275° F (135° C) Max. / 257° F (125° C) Min.
	Closed: 205° F (96° C) Max. / 154° F (68° C) Min.
Oil Flash Point	390° F (199° C)

ELECTRICAL DATA				
RPM	3450			
Electrical Ratings	Heat Sensor	24VDC, 5AMPS	115VAC, 5AMPS	230VAC, 5AMPS
	Seal Fail	300VAC 5mAMPS		
Voltage Tolerance	± 10%			
Internal Start Kit	Start Capacitor = 216 ufd, 250 VAC			
	Run Capacitor = 50 ufd, 370 VAC			

MODEL HIGH HEAD (SLICER)	HP	VOLTS	PHASE	NEC CODE	SERVICE FACTOR	FULL LOAD AMPS	START AMPS	FULL LOAD KW	FULL LOAD KVA
LCHGS2-2081	2	208	1	G	1.0	19.0	92.8	5.51	5.51
LCGHS2-2401		240				17.7	85.8	5.88	5.88

## 2 HP GRINDER PUMPS

### MODEL NO. LCHGS2

**PUMP MODEL** - Pump shall be of the semi-open, centrifugal type, LCHGS2 (High Head), with an integrally built-in grinder unit and submersible type motor.

**OPERATING CONDITIONS** - The pump shall have a non-overloading maximum capacity of \_\_\_ GPM, a maximum total dynamic head of \_\_\_ feet, and shall use a motor rated at 2 HP and 3450 RPM. The grinder unit shall be capable of macerating all material in typical domestic and commercial sewage, including reasonable amounts of foreign objects such as sanitary napkins, disposable diapers, thin rubber, sanitary wipes, floor pads, small wood, plastic and the like to fine slurry that will easily pass through the pump and 1-1/4" NPT discharge.

**CONSTRUCTION** - Major pump components shall be of gray cast iron, ASTM A-48, Class 35, with smooth surfaces devoid of blowholes or other irregularities. All exposed nuts or bolts shall be 304 stainless steel. All metal surfaces coming into contact with the pumpage, other than stainless steel, shall be protected by a factory applied powder coat paint finish to the exterior of the pump..

Sealing design shall incorporate metal-to-metal contact between machined surfaces. Critical mating surfaces where watertight sealing is required shall be machined and fitted with O-rings, designed and constructed to meet FM3615 for Class 1, Division 1, Groups C & D standards. Fittings will be the result of controlled compression of rubber O-rings in two planes and O-ring contact of four sides (rabbet joint construction) without the requirement of a specific torque limit. No secondary sealing compounds, elliptical O-rings, grease or other devices shall be used.

**PUMP IMPELLER** - Pump impeller shall be bronze and threaded onto an AISI 416 stainless steel shaft. The impeller shall be of the semi-open type to provide an unobstructed passage through the volute for the ground solids. Impeller must be dynamically balanced to specification ISO 1940G 6.3 standard.

**SLICER GRINDER CONSTRUCTION** - Maceration is accomplished by a combination of a rotary slicer and stationary slicer plate. Rotary slicer shall consist of (3) blades which protrude away from the inlet. Rotary slicer shall be bolted to shaft within close tolerance of grinding slicer plate. The stationary slicer plate shall consist of engineered-shaped holes for optimum cutting of debris. A slicer plate shall contain grooved slots to eject pump media away from underneath rotary cutter. Slicer plate shall be fastened with countersunk head screws that are flush with surface of plate. Pumps with protruded or exposed head fasteners shall be considered not equal. Both rotary slicer and slicer plate shall be 440C stainless steel hardened to 58-60 Rockwell C. Both rotary slicer and slicer plate shall be 440C stainless steel hardened to 58-60 Rockwell C. Clearance between rotary slicer and stationary plate shall be controlled by an adjustable design. No shims permitted.

**SEALS** - Type 21, domestic manufactured, dual mechanical seal construction mounted in tandem, shall protect the motor. Standard construction of primary seal shall be silicon / carbide. Standard construction of secondary seal shall be silicon / carbide. The seal face shall be lapped to a flatness of one light band. Dual electrodes with 330k ohm resistor shall be mounted in the seal chamber to detect water entering the chamber through the lower seal. Water in the chamber shall cause a red light to turn on at the control box. This signal shall not stop the motor, but shall act as a warning only, indicating service is required. Lip seal arrangements shall not be considered equal.



**MOTOR** - The pump motor construction shall be per NEMA MG-1.1.15 standard and shall be of the submersible type, rated 2 HP, 3450 RPM. The motor shall be for 60 Hz, 208, or 240 volt, single-phase operation. Single-phase motors shall be capacitor start, capacitor run type for high starting torque. Start & run capacitors, and starting switch for operating the motor will be found in the pump cord cap. Major motor operating temperature must not exceed Class B ratings.

The stator winding shall be of the open type with Class N insulation. Any other construction shall not be considered equal. The stator shall be pressed into the cast iron motor housing. Winding housing shall be filled with clean, high dielectric oil that lubricates bearings and seals, transferring heat from windings and rotor to the outer cast housing. Maximum skin temperature of motor assembly shall not exceed a T-4 rating per FM3615 standards.

Single phase motors shall have automatic reset overload protection attached to the top end of the motor windings to stop the motor if the motor winding temperature reaches 130 degrees C. The high temperature shut-off will cause the pump to cease operation, should a control failure cause the pump to run in a dry wet well or any condition that may cause the pump to run outside of the specified operating temperature range.

**BEARINGS / SHAFT** - The motor shall have two heavy-duty ball bearings and one sleeve bearing to support the pump shaft, taking radial and thrust loadings. Bearings shall be designed to an ABEC® System 1 or better. The upper bearing shall be a Conrad type, single row, deep groove ball bearing designed to adequately handle the required radial loads. The lower bearing shall be a single-row angular contact ball bearing designed to adequately compensate for the axial loads and radial forces. Bearings shall be designed to deliver a minimum L-10 bearing life of 100,000 hours when operation is within the limitations of the manufacturer's performance curve. The bearings shall be lubricated in oil and will not require maintenance as described in ANSI/HI 1.4-2010 A.6.

**POWER CORD** - The motor power cord shall be Type SOOW, UL listed, CSA approved cable. The cable jacket shall be sealed at the motor entrance by means of an agency-approved rubber compression washer and compression nut. An epoxy-filled cord cap seals the outer cable jacket and individual leads to prevent water from entering the motor housing. Compression fittings with quick disconnect molded pins shall not be considered equal. Cord shall withstand a pull strain to meet FM requirements.

**MOISTURE PROBE** - Rotor and stator in the motor housing shall be separated and protected from the pumped liquid by an oil filled seal housing incorporated two type 21, Silicon Carbide upper and lower mechanical seals. The seal housing shall be equipped with a moisture sensing probe installed between the seals, and the sensing of moisture in the seal chamber shall be automatic, continuous, and not require the pump to be stopped or removed from the wetwell.