

1. WATERTIGHT CABLE ENTRANCE

Agency-approved, watertight strain relief cord grip with compression grommet protects outer cord jacket (FM Explosion-Proof) or Heavy-duty molded compression grommet protects outer cord jacket. Epoxy-filled inner cord cap provides anti-wicking moisture protection to the motor even if the power cable is cut or damaged.

2. MODULAR PUMP DESIGN

Commonality of parts across the Keen product line minimizes the amount of parts required for servicing. Heavy-duty ASTM A48, Class 35 cast iron components.

3. STRONG MOTOR

Powerful high-torque motor for reliable pump operation. Pressed stator securely holds motor and efficiently transfers heat. Class N insulation with overload protection in oil-filled chamber for cool operation and long motor life.

4. 3-BEARING SUPPORT

Motor / Pump shaft securely held with upper and lower ball bearing plus additional sleeve bearing in lower seal chamber. Long 100,000 hour L-10 bearing life.

5. DOUBLE MECHANICAL SEAL PROTECTION

Dual silicon carbide mechanical shaft seals provide twice the moisture protection for the motor. Dual seals are housed in a secondary oil-filled seal chamber. Tougher silicon carbide seals better handle sand, grit and abrasive materials.

6. MOISTURE DETECTION

Seal leak probe signals alarm in control panel for scheduled maintenance.

7. NON-OVERLOADING HYDRAULIC DESIGN

The recessed centrifugal impeller allows 100% performance curve operation from shut-off to maximum flow without damage to the pump or system. The recessed vortex impeller is out of the passageway of fluid flow, eliminating concerns of blockage or wear.

8. PROVEN GRINDER ASSEMBLY

Hardened (Rockwell 56-60) stainless steel grinder assembly has 30+ years proven field experience. The reversible grinder ring and grinder impeller effectively reduce solids into a fine slurry, easily passable in a piping system without concerns of clogging. Highly efficient 12,400 cuts/second.

9. VERSATILE FLANGE CONNECTION

Combination 2-1/2" and 3" horizontal flange. Industry-standard ANSI Class 125 dimensions.

10. ACCESSORIES

Stainless steel lifting handle included. Anti-Vibration mounting feet OPTIONAL.

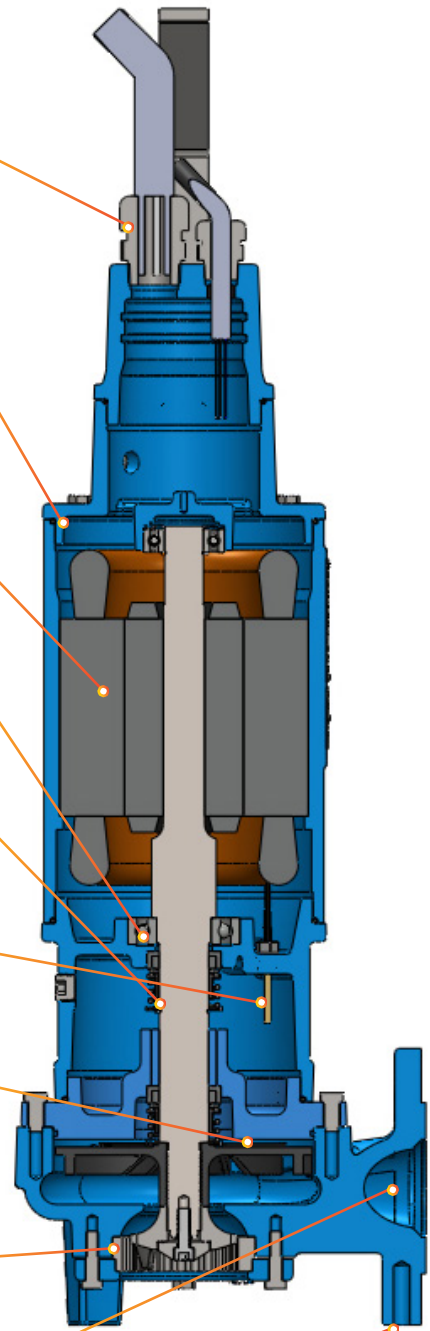

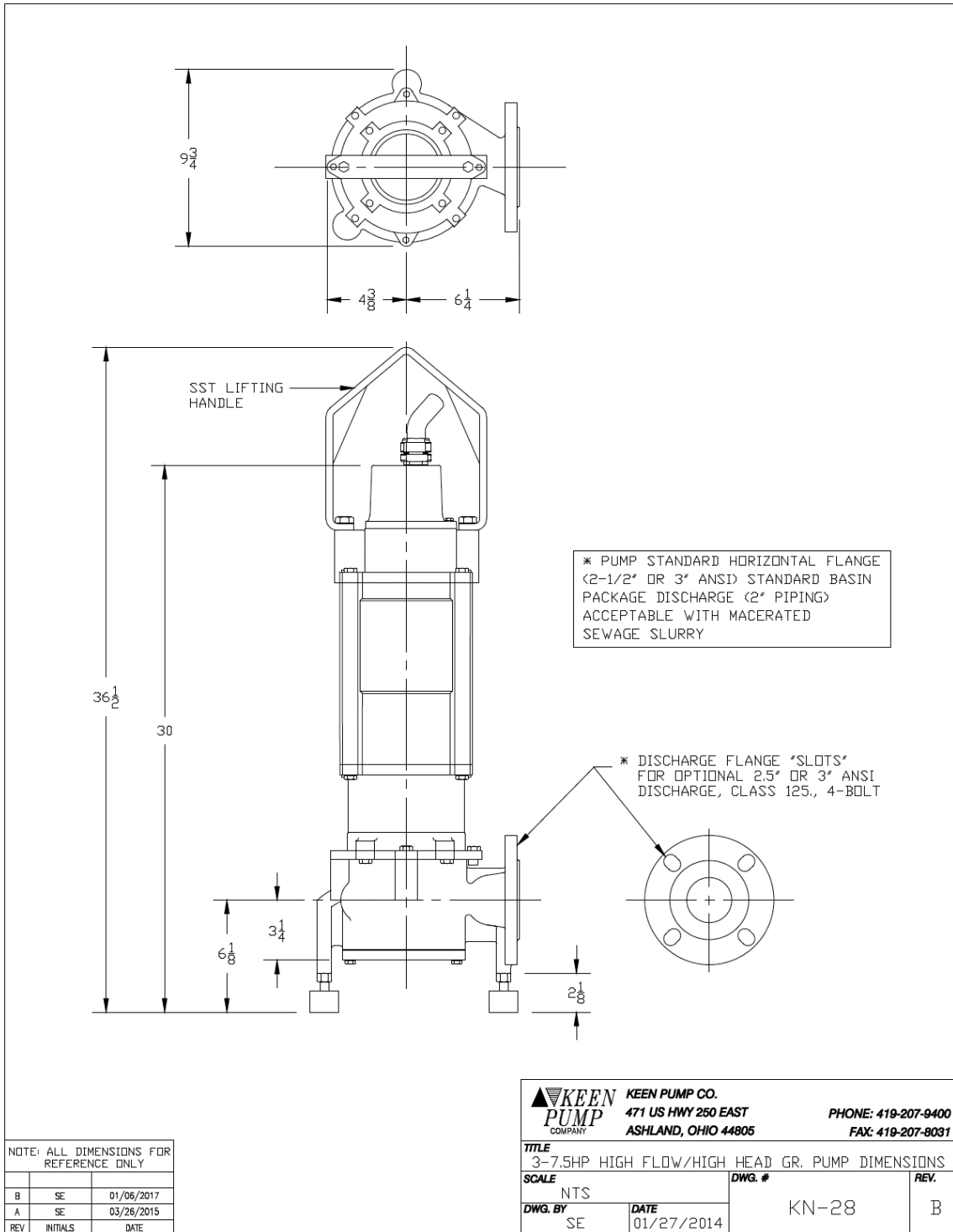



SUBMERSIBLE SEWAGE GRINDER PUMPS

MODELS: KHG(X)3,5,7

1.0 SCOPE

- This specification details the mechanical and electrical requirements for squirrel-cage, induction motors, single and three-phase, designed for wet well submersible grinder pump applications in water and sewage.
- The intent of this specification is to define submersible premium quality grinder pumps which will provide efficient operation with high mechanical integrity under adverse operating conditions for maximum life and minimum life cycle costs.
- This specification covers sewage wet well applications defined by the National Electrical Code (NEC®) as class 1, Division 1, hazardous locations section 501-8(a) requiring explosion-proof construction.

2.0 SUBMERSIBLE MOTOR CONSTRUCTION

- All castings in the stator housing construction shall be ASTM A48 Gray Cast Iron Class 35.
- The submersible motor stator and rotor shall be of an induction type, NEMA® L (Single-Phase) or NEMA® B (Three-Phase) squirrel cage design.
- The stator is to be press-fit in watertight, oil-filled, TENV chamber to provide the maximum heat dissipation.
- The armature assembly of the motor must meet or exceed the balance specification as defined in ISO 1940 G2.5.
- Stator housing shall be filled with clean, high dielectric oil that lubricates bearings and seals, transferring heat from windings and rotor to the outer cast housing.
- Proprietary KEEN I.C.E. oil ensures industry-low operating temperatures. KEEN I.C.E. oil is a synthetic blend with wear-additives, specifically engineered for submersible pump motors.
- Submersible motor design:
 - _____ Horsepower
 - _____ RPM
 - _____ Voltage
 - _____ Phase
 - _____ Frequency
- 1.20 Service Factor
- Insulation system of the submersible motor design shall be of Class N as defined in NEMA® MG-1 and established in accordance with IEEE® std. 1 rated for 392° F (200° C). To include:
 - The stator windings shall be constructed of material to meet the Class N insulation system.
 - The insulation varnish in the system must be applied in a dip and bake manner.
 - Stator lead material must meet or exceed Class N insulation system.
 - Thermal limiting device shall be designed, secured to the stator and constructed to meet the Class N insulation system.
 - The thermal limiting devices shall be attached to each phase winding.
 - The thermal limiting devices shall be used in conjunction with and supplemental to external motor overload protection and must be connected to the motor control center.

- Operation of the motor shall be designed for:
 - Handling pumped media of 140° F (60° C) ambient and shall not exceed NEMA® Class H operating temperature rise of 176° F (80° C).
 - Capable of 10 evenly spaced starts per hour.
 - A combined service factor, in combination with effect of voltage, frequency and specific gravity, shall be at a minimum of 1.00.
 - Acceptable voltage variation is +/- 10%.
 - Acceptable frequency variation is +/- 5%.

3.0 SUBMERSIBLE MOTOR CORD ENTRY CONSTRUCTION

- The cord entry housing shall be ASTM® A48 Grey Cast Iron Class 35.
- Power and control cables shall be secured and sealed to the submersible motor. Construction shall be of a method to provide anti-wicking barriers to the submersible motor.
 - The outer jacket of the power and control cables shall be sealed with an agency-approved, watertight strain relief cord grip fitted with a nitrile compression grommet or rubber compression grommet.
 - The connections between the power cable and the stator leads and control cable and the internal motor control leads shall be potted and encapsulated in a two-part epoxy in the cord entry system.
- All bolted connections in the cord entry construction shall be:
 - Secured with 304 stainless steel fasteners.
 - Secured joints in the construction shall be compression fitted with fluorocarbon o-rings.
- The power and control cables shall be recognized by Underwriters Laboratory® (UL) & Canadian Standard Association® (CSA) and will be delivered in a standard length of 40 foot.
- The cord entry housing shall be fitted with a stainless steel lifting bale sized and of adequate design to securely lift the complete construction of the submersible grinder pump.
- The power and control cables shall be jacketed in a material suitable for submersion, oil resistant, and be flexible for portable installation.
- Cable sizing shall be in accordance to NEC® specifications.

4.0 MECHANICAL SEALS

- Each pump shall be constructed with a tandem mechanical shaft seal system incorporating two independent shaft seal assemblies.
- Seals shall operate in a lubricant reservoir that hydro-dynamically lubricates the seal faces at a constant rate.
- Inboard and outboard seal construction shall be of the following material:
 - Primary stationary ring shall be constructed of silicon carbide face material.
 - Primary rotating ring shall be constructed of silicon carbide face material.
 - Elastomers shall be constructed of Viton® materials.
 - Metal components shall be constructed of stainless steel for corrosion resistance.



- The inboard shall be hydro-dynamically lubricated and operated in a sealed oil reservoir.
- The inboard seal chamber seal shall be designed and constructed to prevent lubricant over-filling and provide adequate lubricant expansion to avoid over-pressuring of the seal.
- The pump shall be capable of operating in the clockwise or counter clockwise direction without damaging the seal faces.
- The pump shall be capable of operating in a dry environment without damage to the seal faces.
- Class 1, Division 1, explosion-proof models shall contain an additional line bearing seal constructed of bronze, CDA836 material, and is mounted in the lower seal housing.
- The line bearing seal will minimize shaft deflection and serve as the flame path for the motor assembly.

5.0 PUMP BEARINGS

- Bearings shall be designed to an ABEC® System 1 or better.
- Each pump shall be constructed with a two-bearing system design.
 - The upper bearing shall be a Conrad type, single row, deep groove ball bearing designed to adequately handle the required radial loads.
 - The lower bearing shall be a Conrad type, single row, deep groove ball bearing designed to adequately handle the required radial loads.
- The bearings shall be designed to deliver a minimum L-10 bearing life of 100,000 hours when operation is within the limitations of the manufacturer's performance curve.
- The bearings shall be lubricated in oil and will not require maintenance as described in ANSI/HI 1.4-2010 A.6.

6.0 PUMP SHAFT

- The pump shaft shall be an extension of the motor shaft. Any other construction that would include coupling of two shafts is not acceptable.
- The pump shaft shall be a Ferritic grade AISI® Type 400 series stainless steel.
 - Pump shaft material crystal structure shall be body centered cubic (bcc).
 - Pump shaft shall be of a ferromagnetic material.

7.0 IMPELLER

- Material shall be ASTM® A536 ductile cast iron. ASTM® A48 gray cast iron shall be unacceptable.
- The design shall be one-piece, 10-vane, vortex flow and dynamically balanced to ISO 1940 G6.3.
- The impeller shall be designed with pump out vanes on the back shroud of the pump impeller to prevent the pump media from entering the outboard seal cavity.
- The impeller shall be threaded to the pump shaft.
 - All wetted fasteners shall be of a corrosion resistant stainless steel material.
- The mass moment of inertia calculations shall be provided by the pump manufacturer upon request.

8.0 GRINDING MECHANISM

- The grinder assembly shall consist of a single rotating grinding cutter and stationary grinding ring secured to the inlet of the volute case.
 - The rotating grinding cutter shall be threaded onto the pump shaft and secured with a washer and bolt.
 - The stationary grinding ring shall be secured in place with a metal clamping ring.
- Both the stationary and rotating grinding mechanisms shall be removable without disassembling the pump.
- No adjustment or shimming grinder assembly shall be necessary.
- The grinder components shall be constructed of a martensitic AISI 440C stainless steel hardened to 56-60C Rockwell.
- The grinder mechanism shall be capable of producing 12,400 cuts/second.

9.0 VOLUTE CASE

- Each pump shall be constructed with a tandem mechanical shaft seal system incorporating two iDesign shall be a single piece and a modified constant velocity.
- Constructed of smooth passage ways large enough that any macerated solid can enter the impeller.
- The discharge is to be of a horizontal centerline configuration.
- The discharge is to be 2-1/2" or 3" ANSI® standard Class 125, 4-bolt configuration.
- Optional - 2" NPT vertical connection.