



KG(X)3

3HP High Flow Grinder Pump

(Class 1, Div. 1, Groups C & D Hazardous Location)

The KEEN PUMP KG(X)3 series centrifugal grinder pumps easily handle residential, commercial or industrial sanitary waste, reducing it to a fine slurry. The KG(X)3 pump is designed for use in pressure sewer applications or any piping network.

The recessed vortex impeller design of the KG(X)3 grinder pump provides troublefree, non-overloading operation over the entire performance curve. The modular design provides quick and easy serviceability. The hardened

PERFORMANCE

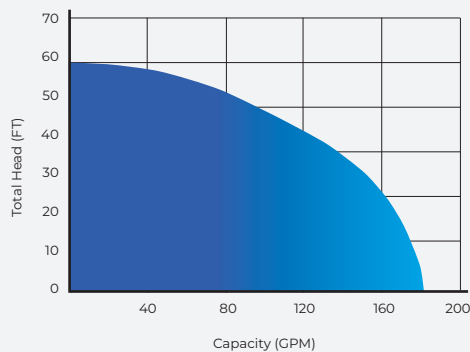

THE KG(X)3 SERIES PUMP FEATURES:

- Interchangeable with Competitor Installations
- Dual Silicon-Carbide Mechanical Shaft Seals w/ Viton® Elastomers
- Pressed-In Motor with Internal Overload Protection
- 3-Bearing Shaft Support (Upper / Lower / Sleeve)
- Internal Moisture Detection
- Strong Motor, 1-Phase (208/230) Volt or 3-Phase (208/230/460) Volt



1. WATERTIGHT CABLE ENTRANCE

Agency-approved, watertight strain relief cord grip with compression grommet protects outer cord jacket. Epoxy-filled inner cord cap provides anti-wicking moisture protection to the motor even if the power cable is cut or damaged. Stainless steel cord grip.

2. MODULAR PUMP DESIGN

Commonality of parts across the Keen product line minimizes the amount of parts required for servicing. Heavy-duty ASTM A48, Class 35 cast iron components.

3. STRONG MOTOR

Powerful high-torque motor for reliable pump operation. Pressed stator securely holds motor and efficiently transfers heat. Class N insulation with overload protection in oil-filled chamber for cool operation and long motor life.

4. 3-BEARING SUPPORT

Motor / Pump shaft securely held with upper and lower ball bearing plus additional sleeve bearing in lower seal chamber. Long 100,000 hour B-10 bearing life.

5. DOUBLE MECHANICAL SEAL PROTECTION

Dual silicon carbide mechanical shaft seals provide twice the moisture protection for the motor. Dual seals are housed in a secondary oil-filled seal chamber. Tougher silicon carbide seals better handle sand, grit and abrasive materials.

6. MOISTURE DETECTION

Seal leak probe signals alarm in control panel for scheduled maintenance.

7. NON-OVERLOADING HYDRAULIC DESIGN

The recessed centrifugal impeller allows 100% performance curve operation from shut-off to maximum flow without damage to the pump or system. The recessed vortex impeller is out of the passageway of fluid flow, eliminating concerns of blockage or wear.

8. PROVEN GRINDER ASSEMBLY

Hardened (Rockwell 56-60) stainless steel grinder assembly has 30+ years proven field experience. The reversible grinder ring and grinder impeller effectively reduce solids into a fine slurry, easily passable in a piping system without concerns of clogging. Highly efficient 16,600 cuts/second.

9. VERSATILE FLANGE CONNECTION

Combination 2-1/2" and 3" horizontal flange. Industry-standard ANSI Class 125 dimensions.

10. ACCESSORIES

Stainless steel lifting handle included. Anti-Vibration mounting feet OPTIONAL.

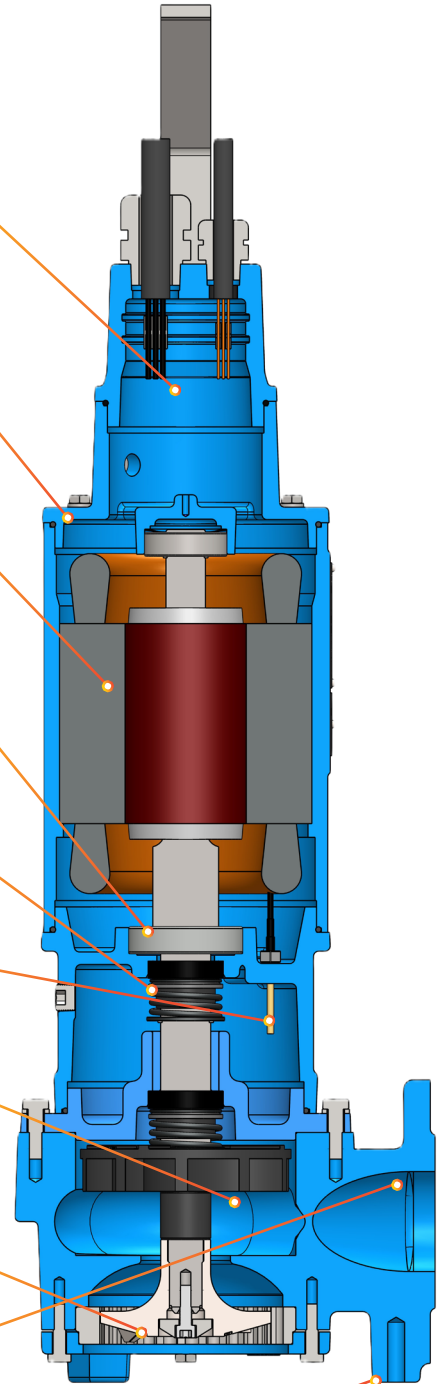

3HP SUBMERSIBLE GRINDER PUMP

GENERAL		MOTOR DATA	
Pump Model	KG(X)3	HP / Power Supply	3HP / 1 ϕ , 60 Hz
		Full Load Amps 208V	37 Amps
PUMP DATA		Start Amps 208V	185 Amps
Date	09/2022	Full Load Amps 230V	34 Amps
Discharge Flange	2-1/2 & 3" ANSI Horizontal	Start Amps 230V	170 Amps
Grinder Ring	25 Slots	Poles / Rated Speed	2P / 3450 rpm
Impeller Type / Std. Dia.	Recessed / 4.50"	Insulation Class	N Class
SINGLE PHASE	START KIT SK-5 includes: Start & Run Capacitors, Start Relay and Mounting Hardware	Start Capacitor	300 ufd, 250 VAC
		Run Capacitor	30 ufd, 370 VAC

PERFORMANCE CURVE

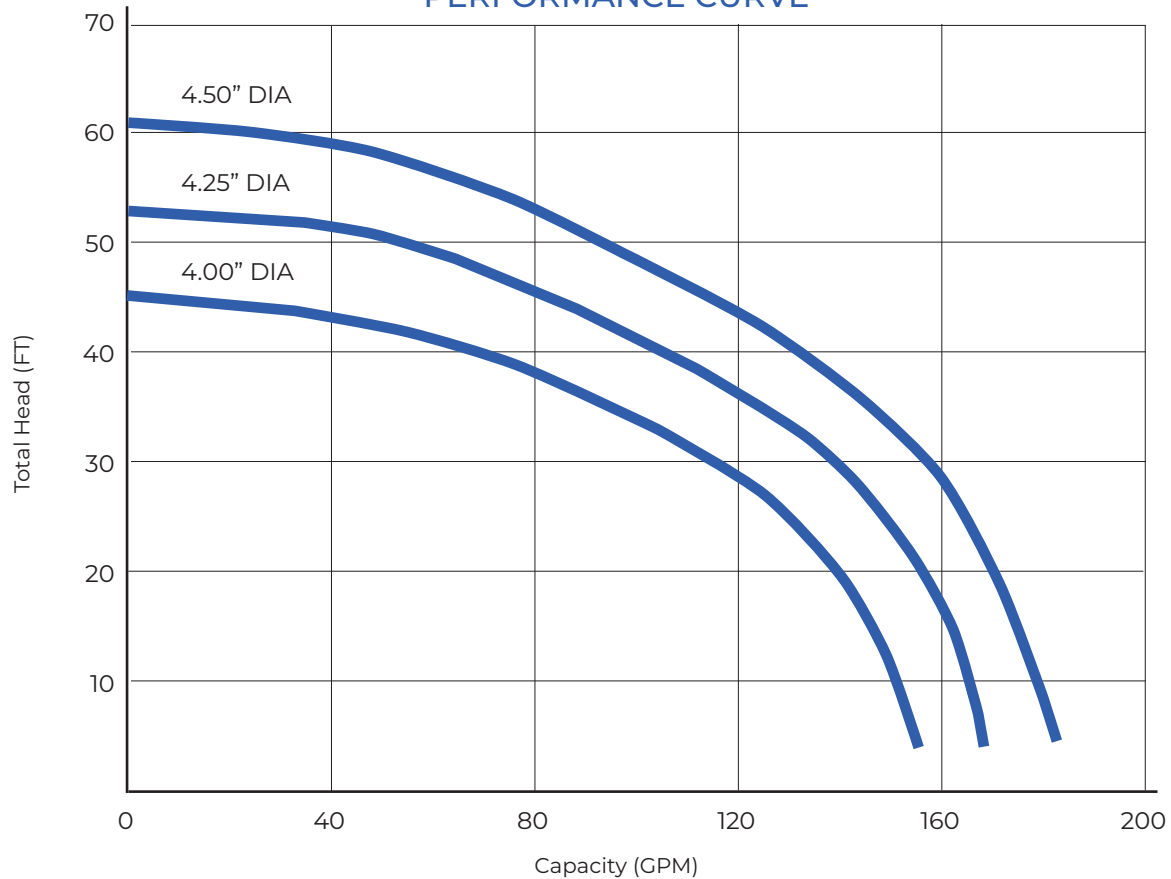

3HP SUBMERSIBLE GRINDER PUMP

GENERAL		MOTOR DATA	
Pump Model	KG(X)3	HP / Power Supply	3HP / 3 ϕ , 60 Hz
PUMP DATA		Full Load Amps 208V	21 Amps
Date	09/2022	Start Amps 208V	105 Amps
Discharge Flange	2-1/2 & 3" ANSI Horizontal	Full Load Amps 230V	18 Amps
Grinder Ring	25 Slots	Start Amps 230V	90 Amps
Impeller Type / Std. Dia.	Recessed / 4.50"	Full Load Amps 460V	9 Amps
THREE PHASE		Start Amps 460V	45 Amps
		Poles / Rated Speed	2P / 3450 rpm
		Insulation Class	N Class

PERFORMANCE CURVE

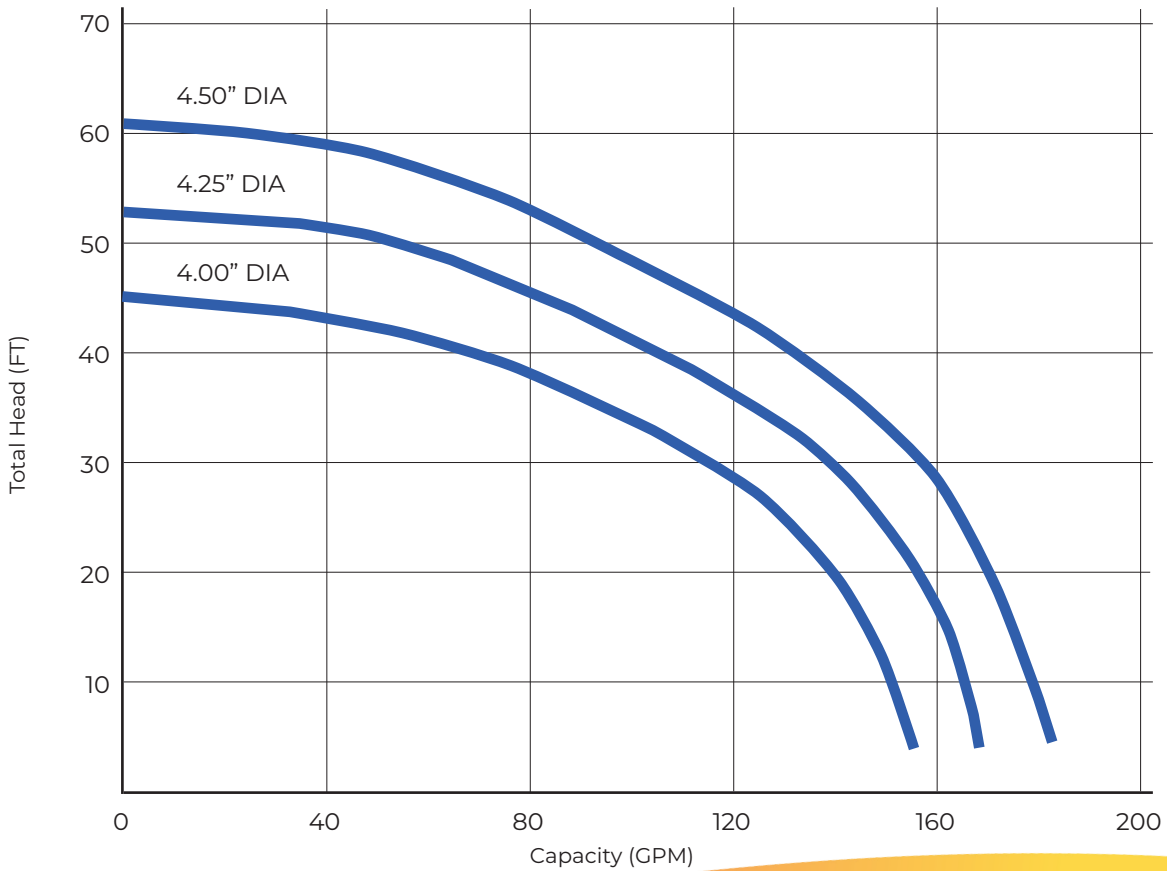

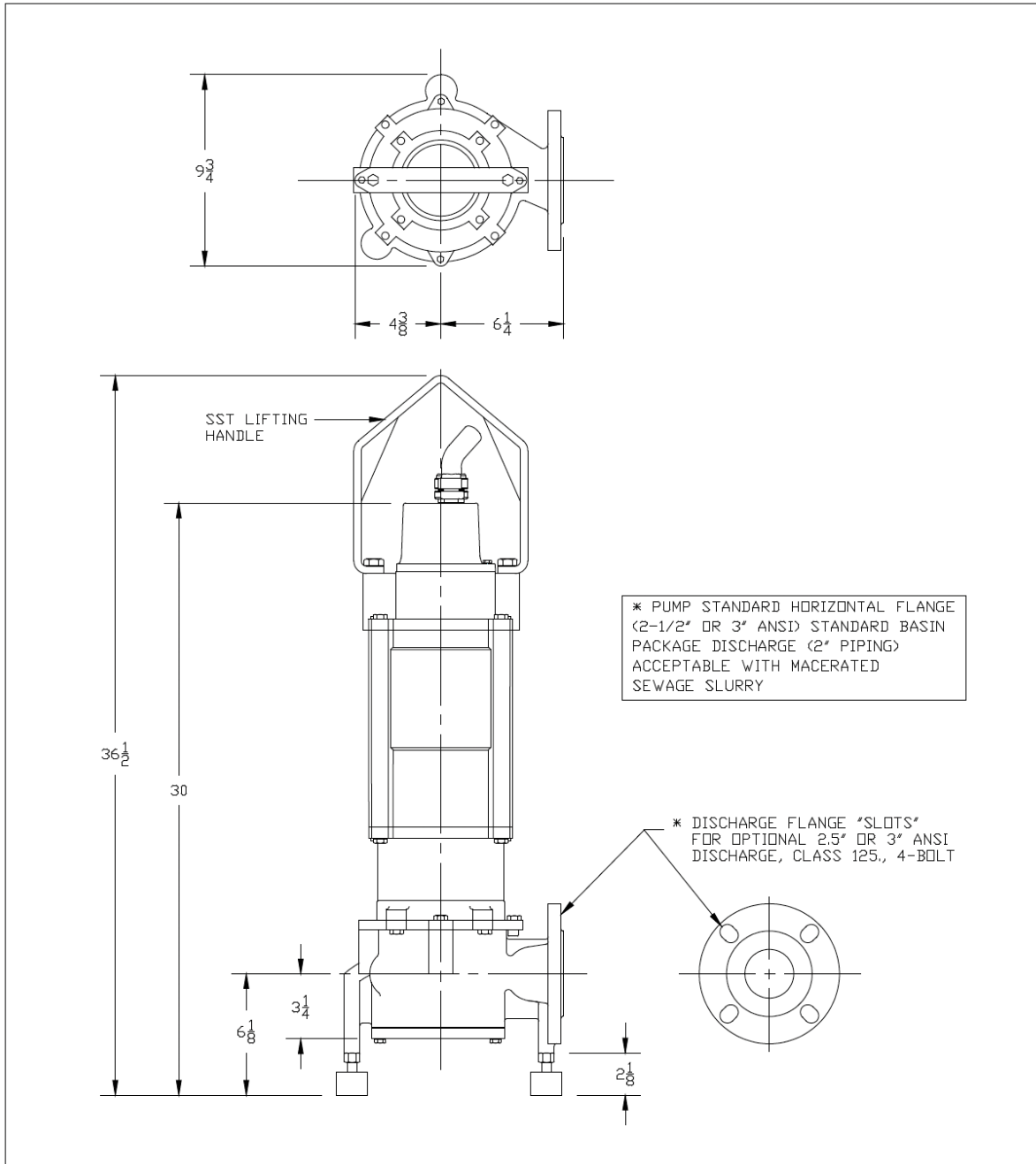

NOTE: ALL DIMENSIONS FOR REFERENCE ONLY

REV	INITIALS	DATE
B	SE	01/06/2017
A	SE	03/26/2015

		KEEN PUMP CO. 471 US HWY 250 EAST ASHLAND, OHIO 44805	PHONE: 419-207-9400 FAX: 419-207-8031
TITLE 3-7.5HP HIGH FLOW/HIGH HEAD GR. PUMP DIMENSIONS			
SCALE NTS		DWG. # KN-28	REV. B
DWG. BY SE	DATE 01/27/2014		