

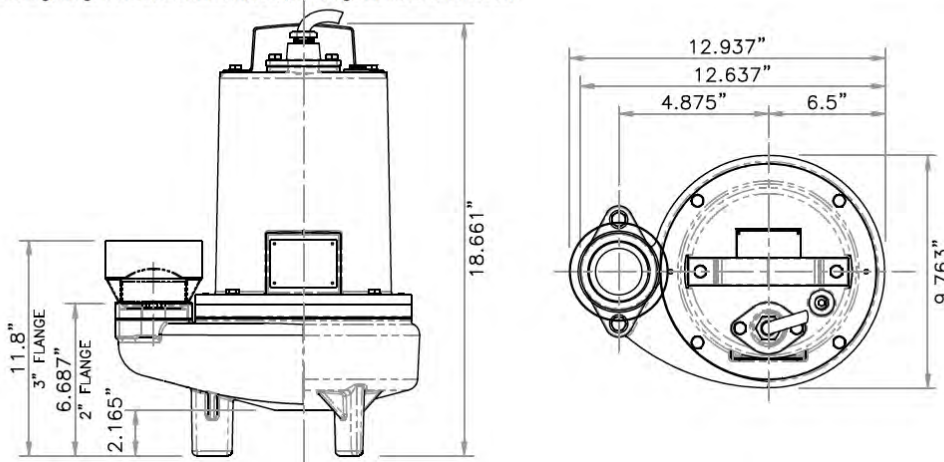

- DISCHARGE:** 2" or 3" NPT female, vertical, bolt on flange.
- SPHERICAL SLD HNDLG:** 2"
- LIQUID TEMPERATURE:** 104° F (40° C) max.
- VOLUTE:** Cast iron ASTM A-48 class 30.
- MOTOR HOUSING:** Cast iron ASTM A-48 class 30.
- SEAL PLATE:** Cast iron ASTM A-48 class 30.
- IMPELLER:** 2 vane, open, with vanes on backside. Cast iron ASTM A-48 class 30.
- SHAFT:** 416 series stainless steel.
- HARDWARE:** 300 series stainless steel.
- SQUARERINGS:** Buna-N.
- PAINT:** Air dry enamel, water based.
- SEAL:** Inboard, single mechanical, oil filled chamber. Silicon carbide, Buna-N elastomer and stainless steel hardware.
- CORD ENTRY:** 30 ft of neoprene cord SJO 14/3, sealed against moisture.
- UPPER BEARING:** Ball, single row, oil lubricated, for radial load.
- LOWER BEARING:** Ball, single row, oil lubricated, for radial and thrust load.
- MOTOR:**
 - Single phase:** NEMA L, permanent split capacitor, oil filled, with overload protection in motor.
 - Three phase:** NEMA B, oil filled. Requires overload protection to be included in control panel.

MODEL	PART No.	HP	VOLTS	PHASE	RPM (Nominal)	MAX AMPS	LOCKED ROTOR AMPS	NEMA CODE	CORD SIZE	CORD TYPE	CORD O.D.	WEIGHT (pounds)
K2PLSE51SS	62180501	0.5	115	1	1750	11.6	18.4	D	14/3	SJO	0.5"	91
K2PLSE51A	62180501A	0.5	115	1	1750	11.6	18.4	D	14/4	SJO	0.5"	93
K2PLSE52SS	62180502	0.5	200/230	1	1750	5.9	14.9	B	14/3	SJO	0.5"	93
K2PLSE53SS	62180503	0.5	200/230	3	1750	4.6/4.2	9.7/11.1	K	14/3	SJO	0.5"	95
K2PLSE54SS	62180504	0.5	460	3	1750	2.2	5.3	K	14/3	SJO	0.5"	95
K2PLSE72SS	62180505	0.75	230	1	1750	10.5	17.5	D	14/3	SJO	0.5"	95
K2PLSE73SS	62180506	0.75	200/230	3	1750	5.5	16	D	12/4	SJO	0.625"	96
K2PLSE74SS	62180507	0.75	460	3	1750	2.2	8	D	12/4	SJO	0.625"	96
K3PL10M4-21S*	62180508	1	230	1	1750	8.3	17.5	A	14/3	SJO	0.69"	84
K3PL10M4-03S	62180509	1	200/230	3	1750	6	16	B	14/4	SO	0.75"	82
K3PL10M4-23S*												
K3PL10M4-43S*	62180510	1	460	3	1750	3	8	B	14/4	SO	0.75"	82

* 3" discharge flange is available for these models, (this change the model to K3PL-5).
 * 2" discharge flange is available for these models, (this change the model to K2PLSE-5S).



SUBMERSIBLE SOLIDS HANDLING PUMP

SERIES: K3PL-S

GENERAL – Furnish and install a quantity of ____ Keen® Pumps submersible sewage pump(s), Model K3PL____S, ____ HP, ____ RPM, ____ phase, 60 Hz, ____ volts, with a 3 inch vertical bolt-on discharge flange connection. Each pump shall be capable of delivering the following performance, ____ U.S. GPM at ____ ft total dynamic head, with a shut off head of ____ ft TDH minimum.

PUMP DESIGN – The centrifugal sewage pump(s) shall be capable of handling 2.5 inch diameter spherical solids of raw, unscreened domestic sewage consisting of water, fibrous materials. The pump(s) shall be capable of handling liquids with temperatures to 104 °F continuous, and shall be capable of running dry for extended periods.

CASTINGS – The volute, seal plates, impeller and motor housing shall be constructed of ASTM A-48 class 30 cast iron.

COATING/HARDWARE – Exterior surfaces shall be painted with a water based air dry enamel. All exposed hardware shall be 300 series stainless steel.

GASKETS – All gaskets shall be of the compression square ring type eliminating critical slips and the possibility of damage during service associated with sliding o-ring sealing arrangements.

IMPELLER – The impeller shall be of 2 vane, open type, solid handling design with pump out vanes on the back side. Impellers shall be capable of being trimmed to meet specific performance characteristics. The impeller shall be dynamically balanced to ISO G6.3 specifications.

MECHANICAL SEAL – A dual seal arrangement shall consist of a Buna-N exclusion seal and a single mechanical design operating in an oil-filled seal cavity. The seal shall be constructed of Silicon carbide faces, 300 series stainless steel hardware, and all elastomer parts to be of Buna-N. The seal shall be commercially available and not a manufacturers proprietary design.

MOTOR – Design shall be of the split capacitor design for single phase units. The pump shall be designed to be nonoverloading throughout the entire pump curve. The rotor and stator assembly shall be of the standard frame design and secured to the pump seal plate by four threaded fasteners allowing for easy serviceability. The motor windings shall be of Class B insulation and operate in a sealed environment containing clean dielectric oil, making it capable of operating in a totally, partially or non-submerged condition for extended periods of time without damage due to the heat being generated. The used dielectric oil must be disposed of as non-hazardous waste. The motor shall meet the standard NEMA L for single phase and NEMA B for three phase.

THERMAL PROTECTION – All single phase motors shall have thermal protection with automatic reset. Three phase motors shall be equipped with a thermal switch embedded in the stator windings and require external overload protection in the control panel.

SHAFT – The pump shaft shall be of a one-piece design and shall be of 416 stainless steel.



BEARINGS – The lower bearing shall be of the single row ball type to accept radial and thrust loads, and the upper bearing of the single ball type for radial loads. Bearings shall operate in an oil bath atmosphere for superior life.

POWER CORD – Power Cord: All pump(s) except 1.5 & 2 HP, 3 phase, shall be equipped with ____ ft of type SOW cord. The cord shall enter a cast iron terminal box assembly that is bolted to the motor housing and sealed with a Buna-N o-ring. The incoming lead wires shall be spliced in the terminal box. After splicing, the terminal box shall be filled with epoxy to seal the outer cable jacket and the individual strands to prevent water from entering the motor housing. Additional sealing and strain relief shall utilize a secondary pressure grommet at point of cable entry. 1.5 & 2 HP, 3 phase pump(s) shall be equipped with ____ ft of type SOW cord. The outer cord shall have an epoxy filled heat shrink tube to prevent water from entering the motor housing. Terminal connectors shall connect the incoming lead wires with the motor lead wires. Additional sealing and strain relief shall utilize a secondary pressure grommet at point of cable entry.

TESTS AND INSPECTIONS: Shall be performed by the pump manufacture.

1. A ground continuity check and motor chamber shall be Hi-potted to test for electrical integrity.
2. Check that motor voltage and frequency matches name plate.
3. The pump shall be pressurized and a air leak test is performed to ensure the integrity of the motor housing.
4. The pump is submerged and operated to determine the unit meets hydraulic performance requirements.