

OPTIONAL :

All Stainless
Steel Construction

**CAPABILITIES:**

- Flows to 2060 GPM
- Heads to 268 Feet
- HP Range 50 - 150 HP
- Voltage/Phase Options 460 / 575V, 3 Phase
- Discharge Connections 4" ANSI Class 125 Horizontal Flange
- Motor Speeds 1750 RPM
- Solids Handling 3"
- Impeller Balanced, Enclosed, 2-Vane
- Motor Service Factor 1.20

K4VK

4" Submersible, Enclosed Impeller

CERAMIC COATED ENCLOSED IMPELLER

- Superior Abrasion Resistance
- Allows The Pump To Operate Better In Any Pressure Or Flow Condition

CERAMIC COATED VOLUTE

- Holds Up to Wear On Inside of Volute Casting Case

BEST MOTOR CONSTRUCTION

- Class "N" (392° F) Highest Temperature
- Motor Will Not Overheat In Continuous Applications

MOTOR GROUND RING PROTECTION

- Allows Motor To Operate With VFD Without Damaging Bearings and Motor
- Ground Ring Safely Diverts Harmful Voltages Away From Bearings

OIL SUBMERSIBLE BEARINGS

- Heavy Duty Bearings Handle The Toughest Applications of High Pressure and Flow Rates
- Angular Contact Bearings



K4VK

KEEN PUMP'S BEARING PROTECTION PROGRAM



Keen's Motor Grounding Ring protects the motor from harmful shaft voltages produced by VFD drives.

Safely conducts the harmful voltages to the grounding ring adding protection for the bearings and extended life.

1

DOUBLE ROW BEARINGS



Heavy Duty Bearings to handle the toughest performances.

- High Pressures
- High Flows

- Handles both Axial and Radial loads in both directions at the same time.
- Double Row Angular Ball Bearings have two rows of balls arranged back-to-back.

3



CERAMIC COATING

Ceramic-coated impellers and volutes for Keen's Solids Handling pumps are designed for superior protection and optimized for long-lasting performance. This allows the pump to operate in any condition without any problems! Impressive sand, grit, abrasion and cavitation resistance!

4

HEAVY DUTY MOTOR

Applications in Electric Motors:

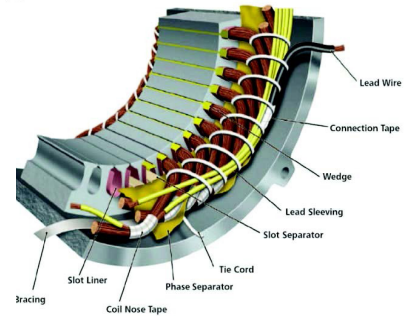

- Class "N" Motors for Keen's Solids Handling pumps.
- **Highest temperature construction (200 degrees celcius) for motors**
- **Class "N" Construction is the best in the industry.**
- Protects your motor from over heating and provides extended motor life. Motors are operating at higher temperatures due to:
 - Motor housing not submerged
 - rapid cycling,
 - running on VFD drives.
 - Continuous longer run times

2

5 CASTINGS

ASTM - Class 35 high tensile strength castings.

6 DURABLE POWDER COAT FINISH

Holds up to the toughest environmental conditions.

7 DUAL SHAFT SEALS

Twice the protection quality silicon carbide faces, viton elastomers, stainless steel construction.

7

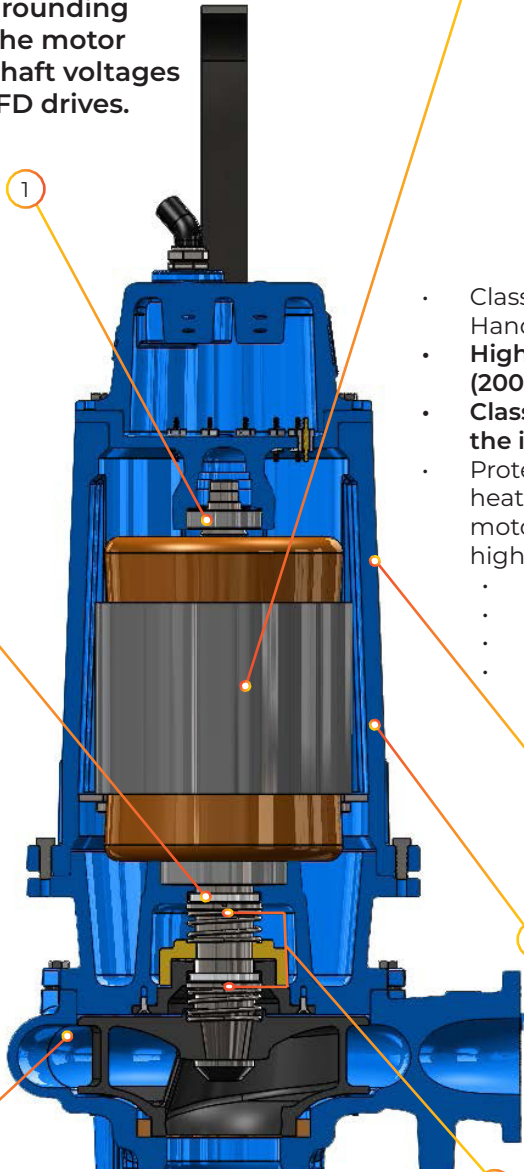

PUMP SERIES	K4VK		4" SUBMERSIBLE SEWAGE PUMPS		
Speed	1750 RPM	Discharge	4"	Solids	3"

GPM: _____ TDH: _____

Performance

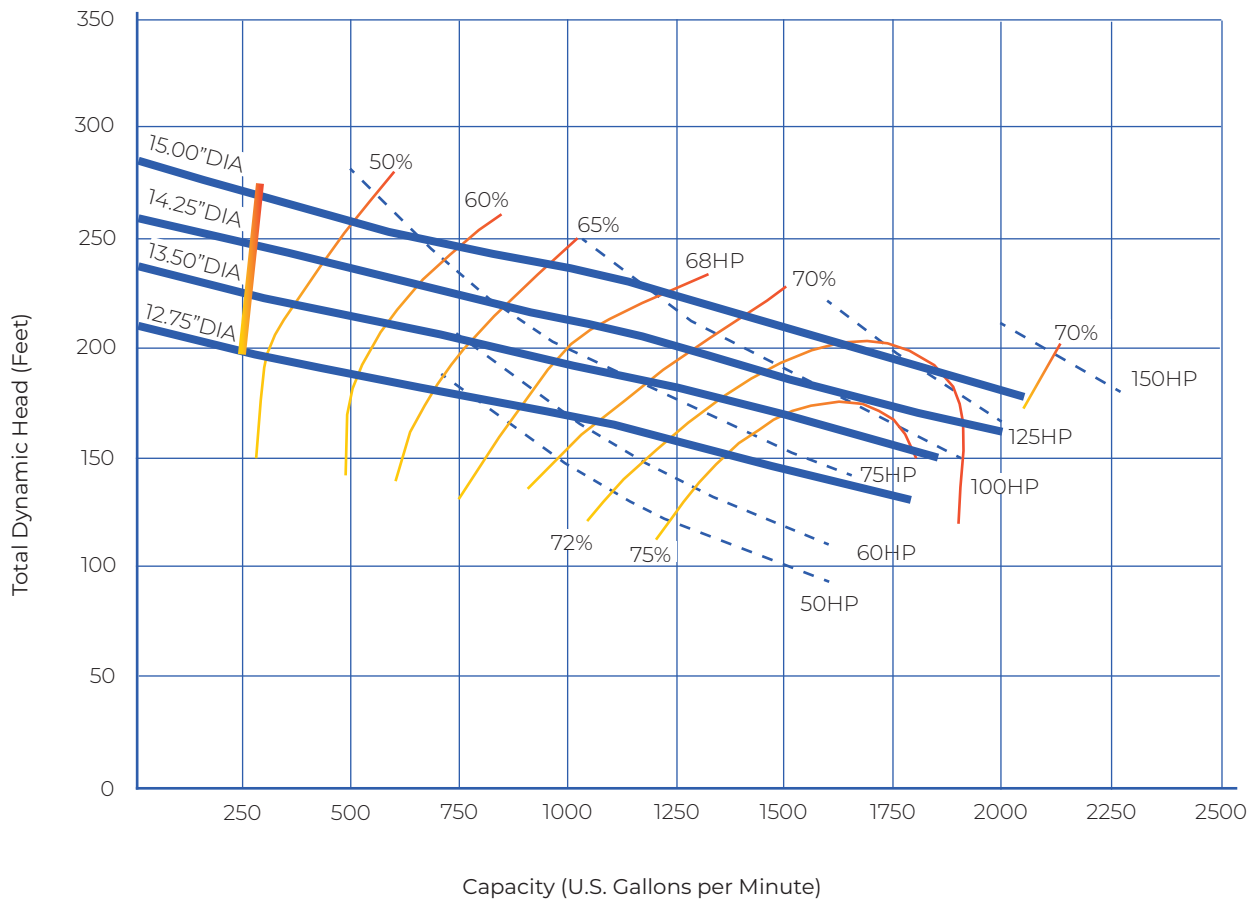

The curves reflect maximum performance characteristics without exceeding full load. Operation is recommended in the bounded area with operational point within the curve limit. Performance curves are based on actual tests with clear water at 70° F and 1280 feet site elevation.



PUMP SERIES	K4VK	4" SUBMERSIBLE SEWAGE PUMPS
DIMENSIONAL DATA		

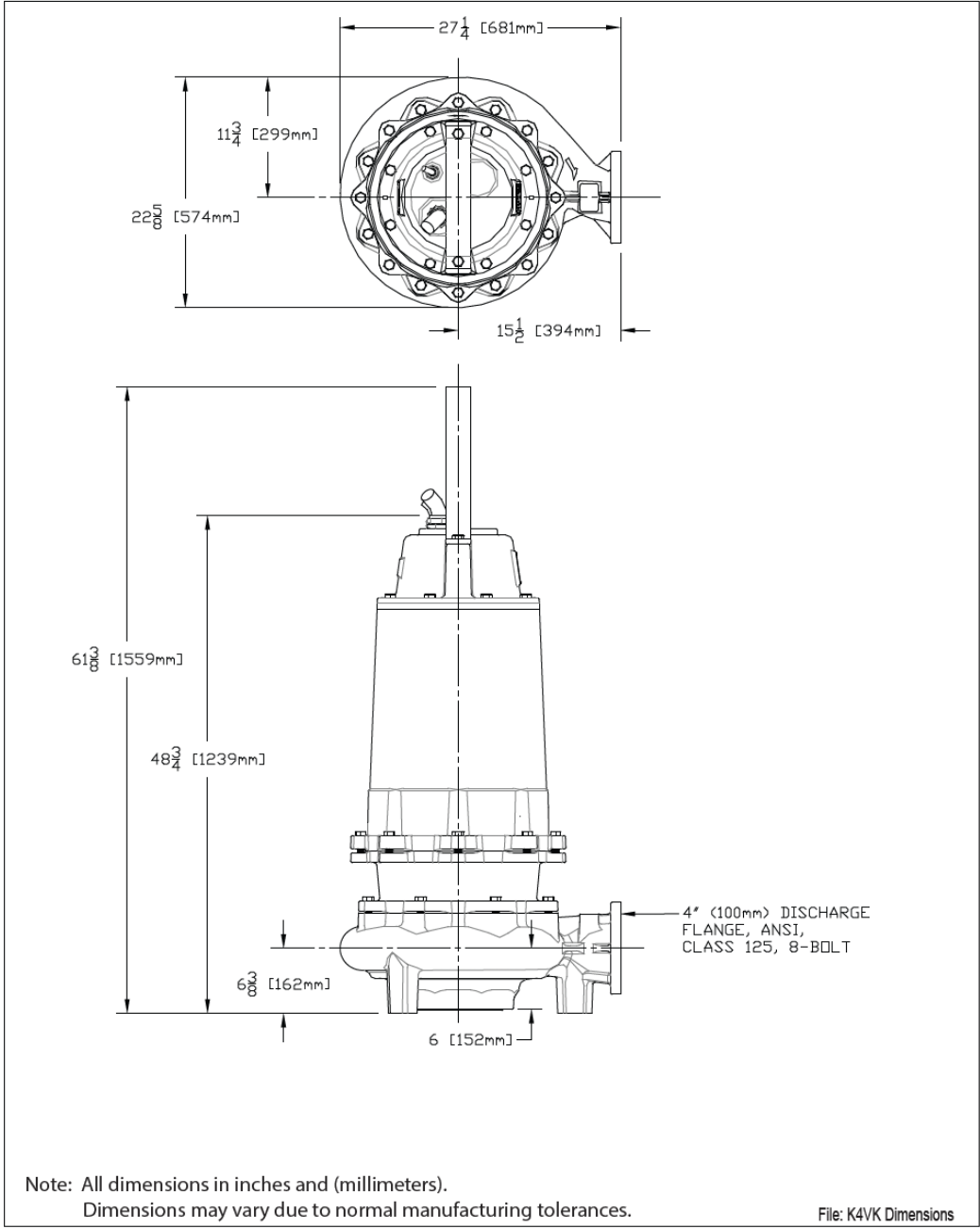



PUMP SERIES	K4VK	4" SUBMERSIBLE SEWAGE PUMPS
SIMPLEX INSTALLATION DIMENSIONAL DATA		

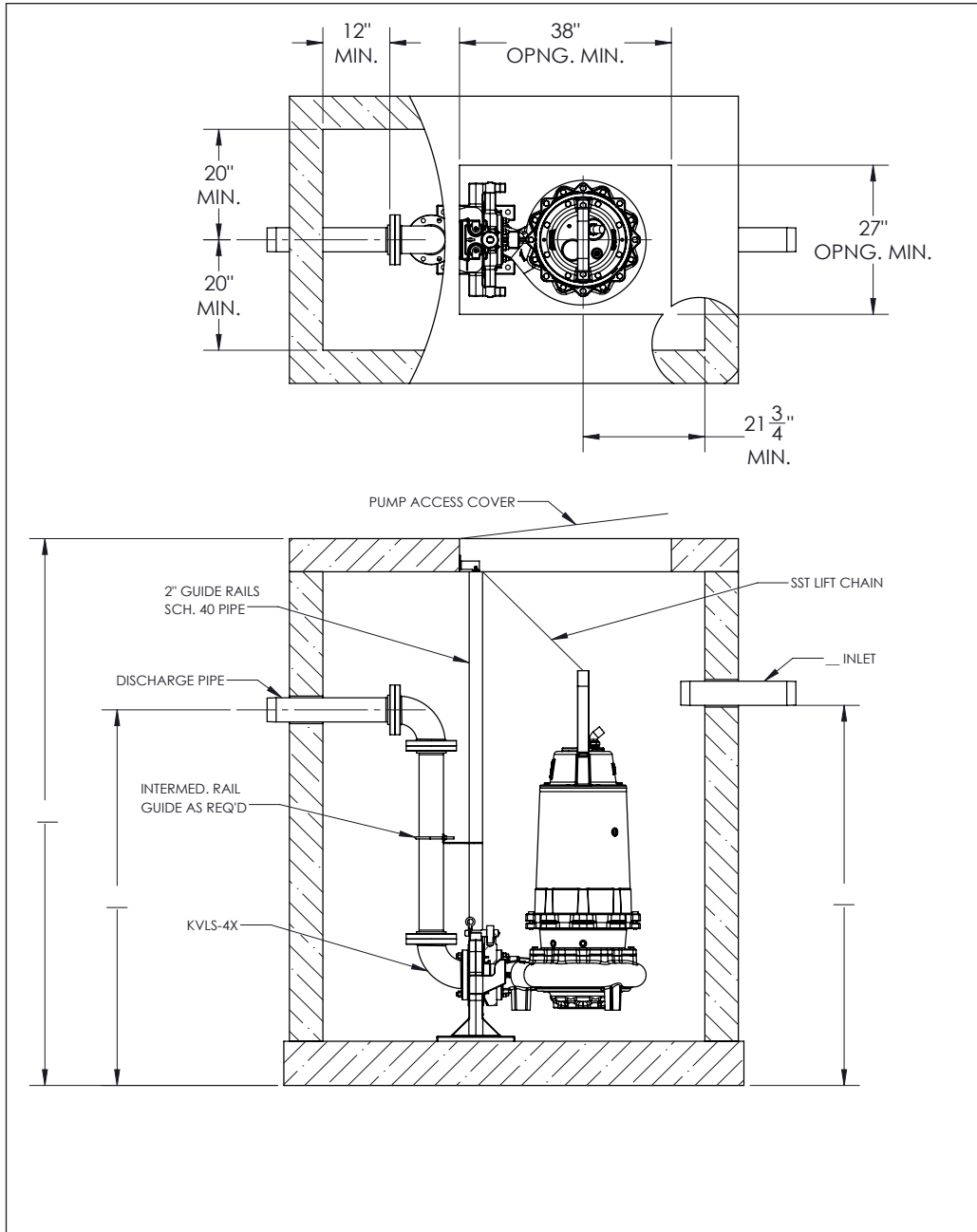

PUMP SERIES

K4VK

4" SUBMERSIBLE SEWAGE PUMPS

DUPLIX INSTALLATION DIMENSIONAL DATA

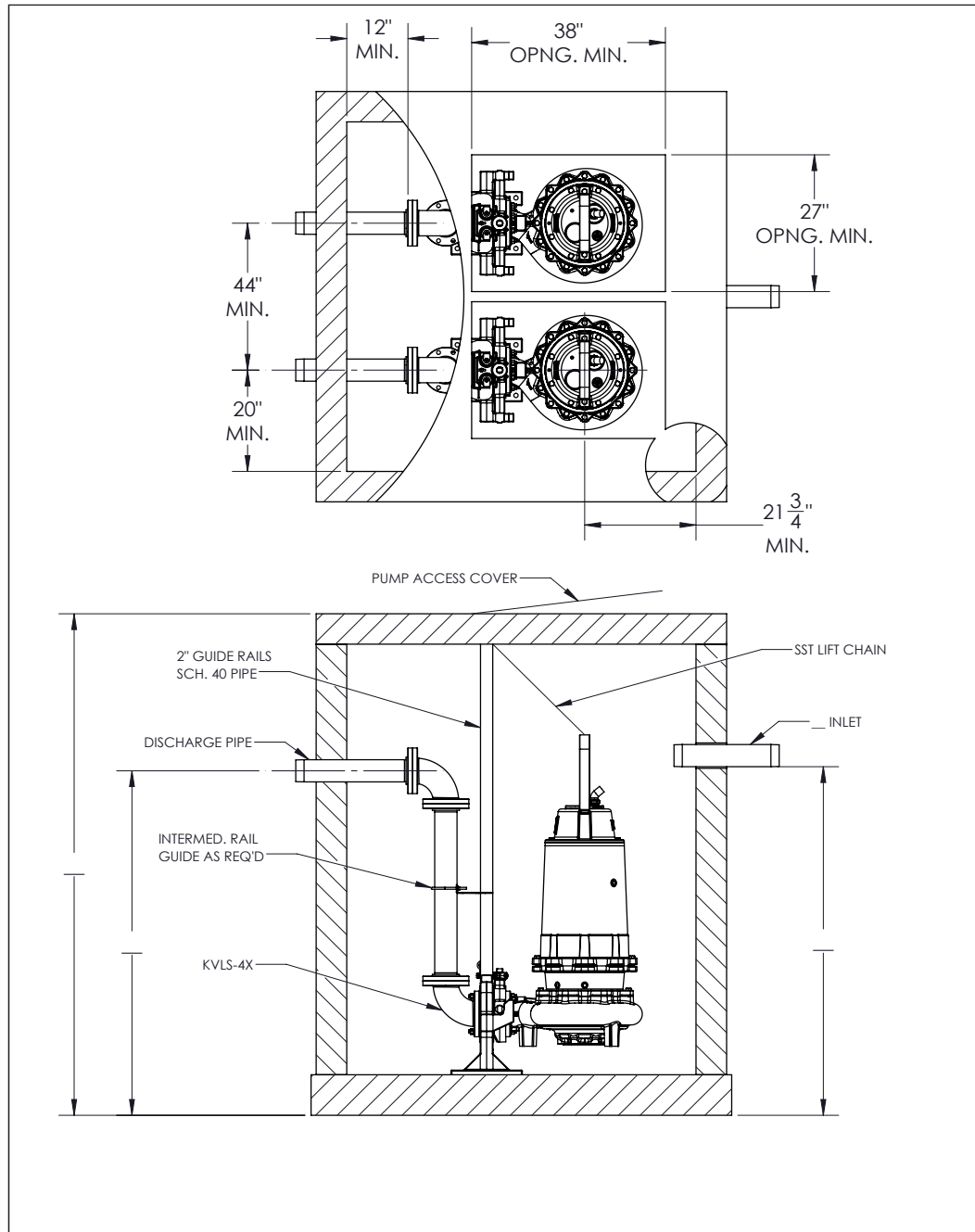



PHYSICAL DATA	
Discharge Size	ANSI 4" Horizontal
Solid Size	3"
Impeller Type	Balanced, Enclosed, 2 Vane
Power/Control Cable Length	40' Standard
Paint	Blue, Powder Coated – Impeller & Inside Volute - Ceramic Coated For Abrasion Resistance

MOTOR CONSTRUCTION	
Motor Type	Enclosed Submersible Oil Filled
NEMA Insulation Code	Class N
Service Factor	1.2
NEMA Design Type	B (3Ø) L (1Ø)
Single Phase Configuration	External Start and Run Components if Applicable
Motor Protection	Thermal Sensors Embedded in the Windings
Maximum Stator Temperature	Class N: 392°F (200°C)
Power Cord Type	Type W - 2000V, 90° C
Control Cord Type	SOOW - 600V, 90° C

MATERIALS OF CONSTRUCTION	
Cord Entry	Cast Iron, ASTM A48, Class 35
Motor Housing	Cast Iron, ASTM A48, Class 35
Bearing Housing	Cast Iron, ASTM A48, Class 35
Volute	Cast Iron, ASTM A48, Class 35 / Ceramic Coated Inside
Wear Ring	Bronze, CDA 836
Impeller	Ductile Iron, ASTM A536, 60-40-18 / Ceramic Coating
Shaft	ANSI 400 Stainless Steel
Inboard Mechanical Seal	Silicone Carbide / Silicone Carbide / Viton Elastomers
Outboard Mechanical Seal	Silicone Carbide / Silicone Carbide / Viton Elastomers
Fasteners	ANSI 18-8 Stainless Steel
O-Rings	Fluorocarbon
Upper Bearing	Conrad Style Single Row Deep Groove Ball Bearing
Lower Bearing	Conrad Style Double Row Angular Contact Ball Bearing
Labyrinth Seal	Bronze, CDA 836

THERMAL DATA

Maximum Liquid	140° F (60° C)		
Maximum Stator	311° F (155° C)		
Heat Sensor	Open:	257° F (125° C) Max. / 239° F (115° C) Min.	
	Closed:	194° F (90° C) Max. / 119° F (48° C) Min.	
Oil Flash Point	390° F (199° C)		

ELECTRICAL DATA

RPM	1750			
Electrical Ratings	Heat Sensor	24VDC, 5AMPS	115VAC, 5AMPS	230VAC, 5AMPS
	Seal Fail	300VAC 5mAMPS		
Voltage Tolerance	± 10%			

HP	VOLTS	PHASE	NEC CODE	SERVICE FACTOR	FULL LOAD AMPS	SF AMPS	LOCKED ROTOR AMPS	RUN KW	START KVA	RUN KVA
50	460	3	K	1.2	63.3	78.4	507.7	46.8	404.5	52.0
	575				52.3	62.7	406.2			
60	460	3	H	1.2	75.2	90.3	507.7	53.9	404.5	59.9
	575				60.2	72.2	406.2			
75	460	3	F	1.2	99.5	119.5	507.7	71.4	404.5	79.3
	575				79.6	95.6	406.2			
100	460	3	F	1.2	132.9	159.5	691.0	95.3	550.5	105.9
	575				106.3	127.6	552.8			
125	460	3	G	1.2	172.1	206.5	962.2	123.4	766.5	137.1
	575				137.1	165.2	769.7			
150	460	3	F	1.2	200.5	240.5	962.2	143.7	766.5	159.7
	575				160.4	192.4	769.7			

MOTOR EFFICIENCIES & POWER FACTOR

HP	PHASE	MOTOR EFFICIENCY %				POWER FACTOR %			
		SERVICE FACTOR LOAD	100% LOAD	75% LOAD	50% LOAD	SERVICE FACTOR LOAD	100% LOAD	75% LOAD	50% LOAD
50	3	93	92	89	84	88	86	83	74
60	3	93	92	89	84	89	87	84	74
75	3	94	93	90	85	89	87	84	75
100	3	94	93	90	85	89	87	84	75
125	3	94	93	91	85	89	87	84	75
150	3	95	94	92	86	90	88	85	76



1.0 SCOPE

- This specification details the mechanical and electrical requirements for squirrel-cage, induction motors, three-phase, designed for wet well and dry well submersible pump applications in water and sewage.
- The intent of this specification is to define submersible premium quality pumps which will provide efficient operation with high mechanical integrity under adverse operating conditions for maximum life and minimum life cycle costs.
- This specification covers sewage wet well and dry well applications defined by the National Electrical Code (NEC®) as class 1, Division 1, hazardous locations section 501-8(a) requiring explosion-proof construction.

2.0 SUBMERSIBLE MOTOR CONSTRUCTION

- All castings in the stator housing construction shall be ASTM A48 Gray Cast Iron Class 35.
- The submersible motor stator and rotor shall be of an induction type, NEMA® B (Three-Phase) squirrel cage design.
- The stator is to be slip-fit in watertight oil-filled, TENV chamber to provide the maximum heat dissipation.
- The armature assembly of the motor must meet or exceed the balance specification as defined in ISO 1940 G2.5.
- Stator housing shall be filled with clean, high dielectric, KEEN ICE oil that lubricates bearings and seals, transferring heat from windings and rotor to the outer cast housing. Proprietary Keen oil ensures industry-low operating temperatures.
- Submersible motor design:
 - _____ Horsepower
 - _____ RPM
 - _____ Voltage
 - _____ Phase
 - _____ Frequency
 - 1.20 Service Factor
- Insulation system of the submersible motor design shall be of Class N as defined in NEMA® MG-1 and established in accordance with IEEE® std. 1 rated for 392° F (200°C). To include:
 - The stator windings shall be constructed of material to meet the Class N insulation system.
 - The insulation varnish in the system must be applied in a dip and bake manner.
 - Stator lead material must meet or exceed Class N insulation system.
 - Thermal limiting device shall be designed, secured to the stator and constructed to meet the Class F insulation system.
 - The thermal limiting devices shall be attached to each phase winding.
 - The thermal limiting devices shall be used in conjunction with and supplemental to external motor overload protection and must be connected to the motor control center.

- Operation of the motor shall be designed for:
 - Handling pumped media of 140° F (60° C) ambient.
 - Capable of 15 evenly spaced starts per hour.
 - A combined service factor, in combination with effect of voltage, frequency and specific gravity, shall be at a minimum of 1.20.
 - Acceptable voltage variation is +/- 10%.
 - Acceptable frequency variation is +/- 5%.
 - Voltage unbalance must not exceed 1% as defined per NEMA M6-112.45.
 - Current unbalance must not exceed 5%.
 - The horsepower of the motor shall be adequately designed to be nonoverloading across the entire pump performance curve, to include pump shutoff and pump run-out.
- All bolted connections in the submersible motor construction shall be:
 - Secured with 304 stainless steel fasteners.
 - Secured joints in the construction shall be compression fitted with fluorocarbon o-rings.
- The submersible motor and pump must be designed, constructed and assembled by the same manufacturer.

3.0 SUBMERSIBLE MOTOR CORD ENTRY CONSTRUCTION

- The cord entry housing shall be ASTM® A48 Gray Cast Iron Class 35.
- Power and control cables shall be secured and sealed to the submersible motor. Construction shall be of a method to provide anti-wicking barriers to the submersible motor.
 - The outer jacket of the power and control cables shall be sealed with an agency-approved, watertight strain relief cord grip fitted with a nitrile compression grommet.
 - The connections between the power cable and the stator leads and control cable and the internal motor control leads shall be potted and encapsulated in a two-part epoxy in the cord entry system.
 - Additional sealing is provided by pump terminal plate, which separates cord cap from motor housing, by PBT encapsulated terminal studs.
- All bolted connections in the cord entry construction shall be:
 - Secured with 304 stainless steel fasteners.
 - Secured joints in the construction shall be compression fitted with fluorocarbon o-rings.
- The power and control cables shall be recognized by Underwriters Laboratory® (UL) & Canadian Standard Association® (CSA) and will be delivered in a standard length of 40 foot.
- The cord entry housing shall be fitted with a stainless steel lifting bale sized and of adequate design to securely lift the complete construction of the submersible pump.
- The power and control cables shall be jacketed in a material suitable for submersion, oil resistant, and be flexible for portable installation.
- Cable sizing shall be in accordance to NEC® specifications.



4.0 MECHANICAL SEALS

- Each pump shall be constructed with a tandem mechanical shaft seal system incorporating two independent shaft seal assemblies.
- Seals shall operate in a lubricant reservoir that hydro-dynamically lubricates the seal faces at a constant rate.
- Inboard and outboard seal construction shall be of the following material:
 - Primary stationary ring shall be constructed of silicon carbide face material.
 - Primary rotating ring shall be constructed of silicon carbide face material.
 - Elastomers shall be constructed of Viton® materials.
 - Metal components shall be constructed of stainless steel for corrosion resistance.
- The inboard shall be hydro-dynamically lubricated and operated in a sealed oil reservoir.
- The inboard seal chamber seal shall be designed and constructed to prevent lubricant over filling and provide adequate lubricant expansion to avoid overpressuring of the seal.
- The pump shall be capable of operating in the clockwise or counter clockwise direction without damaging the seal faces.
- The pump shall be capable of operating in a dry environment without damage to the seal faces.
- Class 1, Division 1, explosion-proof models will be included with an additional labyrinth seal constructed of bronze, CDA836 material, and is mounted directly above the pump seal plate to take radial loads and act as a flame path for seal chamber.

5.0 PUMP BEARINGS

- Bearings shall be designed to an ABEC® System 1 or better.
- Each pump shall be constructed with a two-bearing system design.
 - The upper bearing shall be a Conrad type, double row Angular Contact, deep groove ball bearing designed to adequately handle the required radial loads.
 - The lower bearing shall be a Conrad type, single row, angular contact ball bearing designed to adequately compensate for the axial loads and radial forces.
- The bearings shall be designed to deliver a minimum B-10 bearing life of 100,000 hours when operation is within the limitations of the manufacturer's performance curve.
- Bearings shall be protected from VFD controllers with AEGIS® grounding ring.

6.0 PUMP SHAFT

- The pump shaft shall be an extension of the motor shaft. Any other construction that would include coupling of two shafts is not acceptable.
- The pump shaft shall be a Ferritic grade AISI® Type 400 series stainless steel.
 - Pump shaft material crystal structure shall be body centered cubic (bcc).
 - Pump shaft shall be of a ferromagnetic material.

7.0 IMPELLER

- Material shall be ASTM® A536 ductile cast iron. ASTM® A48 gray cast iron shall be unacceptable.
- The design shall be one-piece, enclosed, 2-vane, double-shrouded and dynamically balanced to ISO 1940 G6.3.
- The impeller shall be designed with pump out vanes on the back shroud of the pump impeller to prevent the pump media from entering the outboard seal cavity.
- The impeller shall be keyed to the pump shaft and retained with a bolt and washer.
 - All wetted fasteners shall be of a corrosion restraint stainless steel material.
- The mass moment of inertia calculations shall be provided by the pump manufacturer upon request.
- Pump impeller shall be ceramic coated. Ceramic coating must be a two component, 100% solids liquid polymer composite for surface application and coating component parts. Two coat process must be applied for best erosion/corrosion resistance including higher temperature application.

8.0 VOLUTE CASE

- Material shall be ASTM® A48 class 35, gray cast iron.
- Design shall be a single piece and a modified constant velocity.
- Constructed of smooth passage ways large enough any solid that can enter the impeller.
- Replaceable, bronze wear ring to provide efficient sealing between volute and impeller suction inlet.
- The discharge is to be of a horizontal centerline configuration.
- The discharge is to be 4" ANSI® standard Class 125, 8-bolt configuration.
- The inside of volute case shall be ceramic coated. Ceramic coating must be a two component, 100% solids liquid polymer composite for surface application and coating component parts. Two coat process must be applied for best erosion/corrosion resistance including higher temperature application.