



471 US Hwy 250 East, Ashland, Ohio 44805
PH: 419-207-9400 FX: 419-207-8031

INSTALLATION AND SERVICE INSTRUCTIONS AND REPAIR PARTS LIST FOR 2HP CENTRIFUGAL SUBMERSIBLE GRINDER SEWAGE PUMPS

***Used in HAZARDOUS Locations Class 1, Division 1,
Groups C & D (FM)**



Note! To the installer: Please provide this manual to owner of equipment or to responsible party maintaining the system.

P/N O&M-KGX2GRINDER

MODELS

Standard Flow w/ Radial Cutters					
CATALOG NO.	HP	PH	VOLTS	CORD	DISCH
KGX2-2001	2	1	200	12-6	1.25
KGX2-2301	2	1	230	12-6	1.25
KGX2-2401	2	1	240	12-6	1.25
KGX2-2003	2	3	200	14-8	1.25
KGX2-2303	2	3	230	14-8	1.25
KGX2-4603	2	3	460	14-8	1.25

High Head w/ Radial Cutters					
CATALOG NO.	HP	PH	VOLTS	CORD	DISCH
KHGX2-2001	2	1	200	12-6	1.25
KHGX2-2301	2	1	230	12-6	1.25
KHGX2-2401	2	1	240	12-6	1.25
KHGX2-2003	2	3	200	14-8	1.25
KHGX2-2303	2	3	230	14-8	1.25
KHGX2-4603	2	3	460	14-8	1.25

High Flow w/ Radial Cutters					
CATALOG NO.	HP	PH	VOLTS	CORD	DISCH
KFGX2-2001	2	1	200	12-6	1.25
KFGX2-2301	2	1	230	12-6	1.25
KFGX2-2401	2	1	240	12-6	1.25
KFGX2-2003	2	3	200	14-8	1.25
KFGX2-2303	2	3	230	14-8	1.25
KFGX2-4603	2	3	460	14-8	1.25

Standard Flow & High Head w/ Radial Cutters INTERNAL CAPACITORS					
CATALOG NO.	HP	PH	VOLTS	CORD	DISCH
KGX2-2001C	2	1	200	12-3	1.25
KGX2-2301C	2	1	230	12-3	1.25
KGX2-2401C	2	1	240	12-3	1.25
KHGX2-2001C	2	1	200	12-3	1.25
KHGX2-2301C	2	1	230	12-3	1.25
KHGX2-2401C	2	1	240	12-3	1.25

Standard Flow w/ Axial Slicers					
CATALOG NO.	HP	PH	VOLTS	CORD	DISCH
KGX2SL-2001	2	1	200	12-6	1.25
KGX2SL-2301	2	1	230	12-6	1.25
KGX2SL-2401	2	1	240	12-6	1.25
KGX2SL-2003	2	3	200	14-8	1.25
KGX2SL-2303	2	3	230	14-8	1.25
KGX2SL-4603	2	3	460	14-8	1.25

High Head w/ Axial Slicers					
CATALOG NO.	HP	PH	VOLTS	CORD	DISCH
KHGX2SL-2001	2	1	200	12-6	1.25
KHGX2SL-2301	2	1	230	12-6	1.25
KHGX2SL-2401	2	1	240	12-6	1.25
KHGX2SL-2003	2	3	200	14-8	1.25
KHGX2SL-2303	2	3	230	14-8	1.25
KHGX2SL-4603	2	3	460	14-8	1.25

Standard Flow & High Head w/ Axial Slicers INTERNAL CAPACITORS					
CATALOG NO.	HP	PH	VOLTS	CORD	DISCH
KGX2SL-2001C	2	1	200	12-3	1.25
KGX2SL-2301C	2	1	230	12-3	1.25
KGX2SL-2401C	2	1	240	12-3	1.25
KHGX2SL-2001C	2	1	200	12-3	1.25
KHGX2SL-2301C	2	1	230	12-3	1.25
KHGX2SL-2401C	2	1	240	12-3	1.25

**Read all instructions in this manual before operating pump.
Most accidents can be avoided by using COMMON SENSE.**

Please Read This Before Installing Or Operating Pump. This information is provided for **SAFETY** and to **PREVENT EQUIPMENT PROBLEMS**. To help recognize this information, observe the following symbols:



IMPORTANT! Warns about hazards that can result in personal injury or indicates factors concerned with assembly, installation, operation, or maintenance which could result in damage to the machine or equipment if ignored.

CAUTION! Warns about hazards that can or will cause minor personal injury or property damage if ignored. Used with symbols below.

WARNING! Warns about hazards that can or will cause serious personal injury, death, or major property damage if ignored. Used with symbols below.



Hazardous fluids can cause fire or explosions, burns or death could result.



Extremely hot - Severe burns can occur on contact.



Biohazard can cause serious personal injury.



Hazardous fluids can Hazardous pressure, eruptions or explosions could cause personal injury or property damage.



Rotating machinery Amputation or severe laceration can result.



Hazardous voltage can shock, burn or cause death.

Only qualified personnel should install, operate and repair pump. Any wiring of pumps should be performed by a qualified electrician.



WARNING! - To reduce risk of electrical shock, pumps and control panels must be properly grounded in accordance with the National Electric Code (NEC) or the Canadian Electrical Code (CEC) and all applicable state, province, local codes and ordinances.

WARNING! - To reduce risk of electrical shock, always disconnect the pump from the power source before handling or servicing. Lock out power and tag.

Prevent large articles of clothing, large amounts of chemicals, other materials or substances such as are uncommon in domestic sewage from entering the system.

During power black-outs, minimize water consumption at the home(s) to prevent sewage from backing up into the house.

Always keep the shut-off valve completely open when system is in operation (unless advised otherwise by the proper authorities). Before removing the pump from the basin, be sure to close the shut-off valve. (This prevents backflow from the pressure sewer.)

Keep the control panel locked or confined to prevent unauthorized access to it.

If the pump is idle for long periods of time, it is advisable to start the pump occasionally by adding water to the basin.



CAUTION! Pumps build up heat and pressure during operation-allow time for pumps to cool before handling or servicing.



WARNING! - DO NOT pump hazardous materials (flammable, caustic, etc.) unless the pump is specifically designed and designated to handle them.

Do not block or restrict discharge hose, as discharge hose may whip under pressure.



WARNING! - DO NOT wear loose clothing that may become entangled in the impeller or other moving parts.

WARNING! - Keep clear of suction and discharge openings. DO NOT insert fingers in pump with power connected.

Make sure lifting handles are securely fastened each time before lifting. Do not operate pump without safety devices in place. Always replace safety devices that have been removed during service or repair.

Do not exceed manufacturers recommendation for maximum performance, as this could cause the motor to overheat.

Secure the pump in its operating position so it can not tip over, fall or slide.

Cable should be protected at all times to avoid punctures, cut, bruises and abrasions - inspect frequently.



Never handle connected power cords with wet hands.

To reduce risk of electrical shock, all wiring and junction connections should be made per the NEC or CEC and applicable state or province and local codes. Requirements may vary depending on usage and location.



Submersible Pumps are not approved for use in swimming pools, recreational water installations, decorative fountains or any installation where human contact with the pumped fluid is common.

Do not remove cord and strain relief. Do not connect conduit to pump.



Products Returned Must Be Cleaned, Sanitized, Or Decontaminated As Necessary Prior To Shipment, To Insure That Employees Will Not Be Exposed To Health Hazards In Handling Said Material. All Applicable Laws And Regulations Shall Apply.

Bronze/brass and bronze/brass fitted pumps may contain lead levels higher than considered safe for potable water systems. Various government agencies have determined that leaded copper alloys should not be used in potable water applications. For non-leaded copper alloy materials of construction, please contact factory.

KEEN PUMP is not responsible for losses, injury or death resulting from a failure to observe these safety precautions, misuse, abuse or misapplication of pumps or equipment.

WARNING!

THE PUMP MUST BE WIRED BY A QUALIFIED ELECTRICIAN, USING AN APPROVED STARTER BOX AND SWITCHING DEVICE.

On 3 phase pumps only, "Motor Protection" must be provided by the installer. All 3 phase pumps must be installed with magnetic starters having 3 leg overload protection in accordance with the NEC (National Electric Code). For duplex installations, both pump motors must have separate overload protection.

Pumps with seal leak detectors must be connected to the proper control circuitry.

DANGER!

HAZARDOUS MOVING PARTS. To reduce risk of injury, disconnect power before servicing. Never put fingers near grinder impeller or in pump inlet when pump cord is connected or pump is operating.

For use with maximum 140 degrees F liquid.

DANGER!

In the initial installation, before sewage is admitted to the basin, there is no danger on entering the basin. **AFTER SEWAGE HAS BEEN IN THE BASIN, THERE IS DANGER.** Sewage water produces methane and hydrogen sulfide gasses, both of which are highly poisonous. A breathing device may be required. Never enter the basin unless cover is open and outside blower is used to force fresh air into the basin. Also the worker in the basin must wear a harness attached to the surface so he can be pulled out in case of asphyxiation. **NEVER WORK ALONE!**

WARNING!

Do not exceed working load limit of lifting chain, cable or rope. Do not use lifting chain, cable or rope where failure could result in loss of life.

Examine all lifting devices, chain, cable or rope for damage before and after each lift. Do not use any lifting devices that are not rated for and designed to lift the weights involved with these pumps. **DO NOT LIFT PUMP BY POWER CORD.**

Do not install or remove pump with person(s) in the basin.

This pump is designed to handle materials which could cause illness or disease through direct exposure. Wear and use protective clothing when working on the pump or piping.

WARNING!

Any wiring to be done on pumps should be done by a qualified electrician.

NEVER operate a pump with a power cord that has frayed or brittle insulation.

NEVER let cords or plugs lay in water.

NEVER handle connected power cords with wet hands.

NEVER be in contact with the liquid being pumped while pump cord is connected to electrical supply.

Only qualified personnel should install, operate or repair pump.

***** **USE AND CARE** *****

DO NOT pump hazardous material not recommended for pump. **NEVER** introduce:

- Explosives
- Flammable Material
- Lubricating Oil and/or Grease
- Chemicals, Solvents, etc.
- Gasoline
- Any Petroleum Product

Regulatory agencies advise that the following items should not be introduced into any sewer:

- Glass
- Metal
- Diapers
- Clothing, socks, rags, etc.
- Plastic objects (toys, utensils, etc.)
- Sanitary napkins or tampons

DO NOT pump without safety devices in place.

For hazardous locations, use pumps listed and classified for such locations.

DO NOT use non-explosion rated pumps in locations considered hazardous in accordance with the National Electric Code, ANSI/NFPA 70-1993.

IMPORTANT!

KEEN PUMP is not responsible for losses, injury or death resulting from failure to observe these safety precautions.

General Information

Thank you for purchasing your Keen Pump. To help ensure years of trouble-free operation, please read the following manual carefully.

Attention:

This manual contains important information for the safe use of this product. Read this manual completely before using this product and refer to it often for continued safe product use. **DO NOT THROW AWAY OR LOSE THIS MANUAL.**

Pump Warning

IMPORTANT: Read all directions before replacing any parts.

WARNING: Before handling these pumps and controls, always disconnect the power first. Do not smoke or use sparkable electrical devices or flames in a septic (gaseous) possible septic sump.

Application: These pumps are designed for on-site residential sewage discharge applications with a pH ranging from 6 to 9, specific gravities from 0.9 to 1.1, viscosities ranging from 28 to 35 S.S.U., and temperatures up to 140F.

Receiving Pump: Pump should be checked on arrival for possible concealed shipping damages. Any damage should be reported immediately to delivery carrier. Claims for damage must originate at the receiving end. Claims for shipping damage cannot be processed by the factory.

Codes:

All local wiring codes must be observed. Consult the local inspector before installation to avoid delays that can occur due to rejection after job is finished.

CALIFORNIA PROPOSITION 65 WARNING:

WARNING! This product and related accessories contain chemicals known to the State of California to cause cancer, birth defects or other reproductive harm.

Pumps Not Operating or in Storage:

Pumps with carbon ceramic seals must have impellers manually rotated (6 revolutions) after setting non-operational for 3 months or longer and prior to electrical start-up.

Seal Failure Probes:

All hazardous location submersible pumps have two factory-installed moisture detectors (seal failure probes). They are in a normally open series circuit in the seal chamber. Under normal operating conditions the circuit remains open. If the lower seal leaks and moisture enters this chamber, the moisture would settle to the bottom of the chamber and will complete the circuit between the moisture

detectors. This circuit must be connected to a sensing unit and signaling device. This is supplied in a Keen Pump control panel.

NOTE: Failure to install such a device negates all warranties by Keen Pump.

Heat Sensors:

All motors in this family have heat sensors on or embedded in the motor winding to detect excessive heat. This prevents damage to the motor. If the sensor trips due to excessive winding temperature, the starter in the panel breaks power to the pump. Once the sensor resets, the starter is to be reset (automatic for FM) for continued operation of the pump. This circuitry is supplied in a Keen Pump control panel. The sensors are set to trip at 120°C.

NOTE: Failure to install such circuitry would negate FM approval and all warranties by Keen Pump.

Power Cords:

The power cord and heat sensor seal failure cord are potted into the connection box cap. The cords must not be spliced.

NOTE: Each cable has a green lead. This is the ground wire and must be grounded properly per N.E.C. and/or local codes. During normal maintenance procedures power cords should be inspected for abnormal wear and replaced accordingly.

Overload Heater:

If the Keen Pump electrical panel is not used, starters with 3-leg overload relay must be supplied on 3-phase pumps. Each leg is to have an identical heater sized in accordance with the nameplate amps on the motor housing. The amp draw on these submersible motors is slightly higher than a corresponding horsepower surface motor, so heaters must be sized by the nameplate rating.

Single-phase pumps with capacitor start have a run and a start winding, each drawing a different current. To adequately protect these windings with the appropriate heaters, consult the factory.

NOTE: Red lead is always the start winding of the single phase pump.

Pump Installation

Installing Pump in Sump:

Before installing pump in sump, lay it on its side and rotate impeller. Impeller may be slightly stuck due to factory test water so it must be broken loose with a small bar or screwdriver in edge of vanes. The impeller should turn freely. Do not connect the power until after this test.

Clean all trash and sticks from sump and connect pump to piping. A check valve must be installed on each pump.

Location:

If pumps are installed in an existing basin or concrete sump, the piping can either be connected permanently or rails and brackets can be furnished for mounting to walls of basin. In either case, be sure the Keen Pump solids handling ball check valve is used and that the pumps are submerged in a vertical position. The complete factory-built packaged system is recommended for the most satisfactory and economical installation.

Making Electrical Connections:

All electrical wiring must be in accordance with local code, and only qualified electricians should make the installations. All wires should be checked for shorts to ground with an ohmmeter or Megger after the connections are made. This is important, as one grounded wirer can cause considerable trouble.

IMPORTANT: If equipment is not properly wired and protected as recommended, Keen Pump warranty is void. See wiring diagrams below.

Heat Sensor and Seal Failure Connections:

If a Keen Pump is used, terminal blocks are provided for heat sensor and seal failure connections. If a control panel is supplied by others, it must allow heat sensor and seal failure terminations.

Installing Sump Level Control Floats:

In either simplex, duplex or triplex systems the lower or turn-off control is to be set to maintain a minimum level in the sump. This level shall be minimum 1/3 of the pump submerged. The second, or turn-on control, is set above the lower turn-off control. The exact distance between the two floats must be a compromise between a frequent pumping cycle (10 starts per hr. max.) to control septicity, solids and a slower cycle for energy economy. This distance should be determined by the engineer or consulting engineer, depending on the conditions of the application.

USAGE:

The 2 HP grinder pumps are for pumping domestic sewage. One pump can handle the sewage from a maximum of 2 homes.

These pumps are not to be used for pumping commercial or industrial sewage from factories, schools, motels, apartments, etc.

This pump is intended to grind and pump all normal sewage for home use. It will handle reasonable quantities of disposable diapers, sanitary napkins, paper towels, rubber material, wood, cigarette butts, string, plastic and other material not normally found in sewage.

CAUTION!

Pump is not to be disassembled in the field except at FM authorized service stations or at the factory. Warranty is void if pump is taken apart for any reason other than to replace grinder impeller and grinder ring, which is covered in these instructions.

PACKAGING

Each pump is packaged with 30 feet of power cord in a carton that is marked with the Model Number. Longer cords are available – consult factory.

INSPECTING PUMP

Before making any piping or electrical connections, check pump for any shipping damage. Turn grinder impeller to be sure it is free. **DO NOT TURN IMPELLER WITH FINGERS AS EDGES ARE SHARP.** Use allen wrench in the impeller screw to turn the impeller.

CAUTION!

No persons should be in the basin when pump is lowered into position! **DO NOT** lift pump in a manner where failure could result in loss of life.

After pump is installed in basin, **NEVER WORK ON MOTOR OR GRINDER UNIT WITHOUT DISCONNECTING MOTOR LEAD WIRES FROM CONTROL PANEL. DO NOT RELY UPON OPENING THE CIRCUIT BREAKER ONLY!**

ELECTRICAL:**MOTOR OVERLOAD PROTECTION**

Single phase motors are provided with an on-winding thermal overload switch. If motor overloads or overheats for any reason, the switch opens, stopping motor. As soon as the motor cools to normal temperature, the switch automatically closes and restarts motor.

MOISTURE DETECTION

All 2 HP, dual seal grinder pumps contain dual electrodes (w/ resistor) for detecting water within the unit. The electrodes are housed within the secondary seal chamber, isolated from the motor chamber. If the electrodes detect water within the oil-filled housing, it will close the circuit to the red alarm light in the control panel, indicating the pump must be serviced before the upper seal fails.

MOTOR POWER CORDS

Pump models with seal leak detector, single phase use a 12AWG-6C cord, three phase use a 14AWG-8C cord. The three power conductors are BLACK, WHITE and RED. The ORANGE and BLUE conductor connects to the seal leak probe and GREEN conductor connects to the ground screw inside the cord cap.

For single phase,
BLACK is “Common”
WHITE is “Run”
RED is “Start”.

IMPORTANT!

Ground wires must be connected in the control box to grounding bar, which is connected to a good suitable ground.
MOTOR IS NOT SAFE UNLESS PROPERLY GROUNDED.

IMPELLER ROTATION: When looking at the bottom of the pump and through the inlet of the volute, rotation of the impeller is **COUNTER-CLOCKWISE.**

Pump Operations

WARNING: Keep Hands and clothing away from cutters and impeller!

1. If pump is 3 phase, rotation of impeller must first be checked. Lift pump from sump, lay down, and quickly turn pump on and off. The impeller should turn counterclockwise when viewed from suction end. If rotation is incorrect, turn off main breaker and interchange any two line leads to motor for correct rotation. If pump is single phase, no rotation check is necessary.
2. Run water into sump until motor is submersed.
3. Open gate valve in discharge line.
4. Turn pump on. If pump runs and sump liquid does not pump down, stop pump and close discharge gate valve. Lift pump until sealing flange is open to vent trapped air. Lower pump, open discharge valve, and start pump again.
5. If pump is 3 phase, permanently piped, and still does not operate properly after venting, rotation is incorrect and can be reversed by interchanging any two line leads.
6. Level controls should be set in accordance with “Installing Sump Level Control Floats”.

CAUTION: Be sure ground wire is connected to good ground. This is important for safety.

Pump Maintenance

As motors are oil-filled, no lubrication or other maintenance is required. If heat sensor and seal failure are properly hooked up, no attention is necessary as long as seal failure indicator light does not come on. To ensure continuity of seal sensor leads, a test light is provided on intrinsically safe KEEN PUMP panels as standard equipment. Pump should be checked every 3 months for corrosion and wear.

Servicing Instructions:

Field Service on KEEN PUMP Hazardous Location Pumps:

If a KEEN PUMP hazardous location pump is used in a hazardous location, or if the pump is still under warranty, pump must be returned to factory for service or repair. This ensures the integrity of the hazardous location rating of pump and complies with warranty requirements.

Disconnecting Pump Cords:

If a KEEN PUMP hazardous location pump is to be removed from its location, pump cords may be disconnected at the control panel (on sump mounted control panels) and cord assembly taken with pump.

CAUTION: If cord openings from sump to control panel are open, gases from sump could enter panel and an explosive condition could exist. Seal openings properly!

Replacing Cords:

The power cord and heat sensor/seal failure cords are epoxy-potted into the cord cap, forming the cord and cap assembly. If cords require replacement due to damage or cords being too short, cord and cap

assembly must be replaced as a complete assembly from the factory. Check pump for proper rotation before returning to normal service.

Replacing Lower Seal, Impeller or Volute:

The wet end components may be repaired or replaced by an authorized KEEN PUMP service facility without compromising the hazardous location rating to pump.

NOTE: Anytime seal is disturbed, it MUST be replaced.

SUBMERGENCE LEVELS - RAIL MOUNTED PUMPS

PUMP	LIFTOUT MODEL	A BOTTOM OF WELL TO INLET	B "KEEN" RECOMMENDED MINIMUM SUBMERGENCE LEVEL
KE102/103	KL2	3-1/2"	15"
KF/HG2	KL1(CV)	3-1/2"	15"
KPCG	KL1(CV)	3-3/4"	19"
K(H)GS2	KL1(CV)	3-3/8"	15"
KHHG2	KL1(CV)	3-1/2"	21"
KHHG2H	KL1(CV)	3-1/2"	21"
KG3,5,7,103	KL3H	4-3/4"	22"
KHG3,5,7	KL3H	5-3/4"	22"
KGP75-150	KL3H	4-3/4"	28"
K3RN	KL3H	5-3/4"	28"
K3VN	KL3H	4-1/2"	27"
K3RH	KL3H	5-3/4"	23"
K4RH	KL4	6-1/4"	24"
K4RN (3450)	KL4	6-1/4"	28"
K4RN (1150/1750)	KL4	5-1/8"	28"
K4VN	KL4	5-1/8"	27"
K4RP (3450)	KL4	5-1/2"	28"
K4RP (1150/1750)	KL4	7-1/2"	32"
K4VP	KL4	7-1/2"	30"
K4RB (3450)	KL4	9-1/8"	36"
K4RB (1750)	KL4	8-1/2"	36"
K4VB	KL4	7-1/2"	35"
K4VK	KL4	6-1/2"	42"
K6VB	KL6	8-3/8"	38"
K8VK	KL8	16"	52"
K12VK	KL12	15-1/2"	61"
K14VK	KL14	15-1/2"	61"

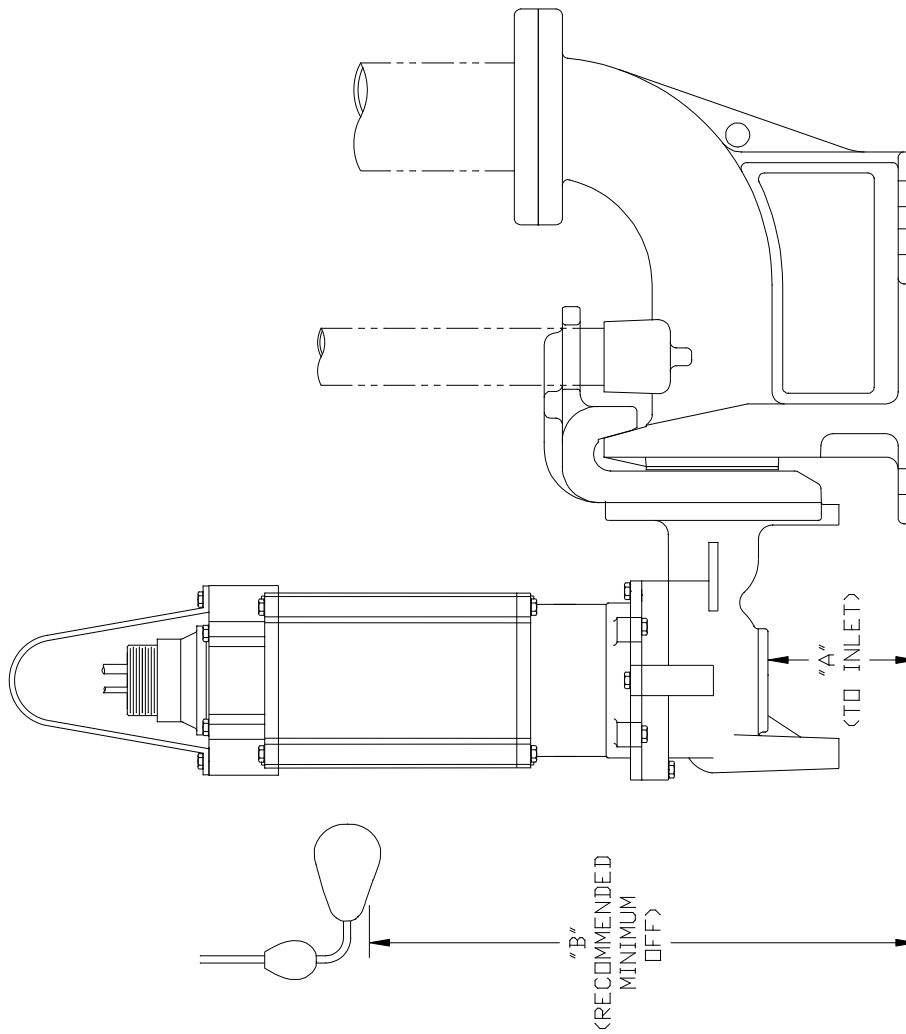

NOTE: ALL DIMENSIONS FOR REFERENCE ONLY

REV	INITIALS	DATE
B	SE	10/09/2015
A	SE	03/16/2015

471 US HWY 250 EAST
ASHLAND, OHIO 44805
PHONE: 419-207-9400
FAX: 419-207-8031

TITLE SUBMERGENCE LEVELS - WASTEWATER PUMPS		REV.
SCALE NTS	DWG. # KN-903	B
DWG. BY SE	DATE 9/24/2014	

REPLACING GRINDER IMPELLER AND SHREDDING RING “RADIAL CUTTERS”

Note: This is the only disassembly operation permitted in the field.
All other repairs must be performed at an authorized service center or the factory.

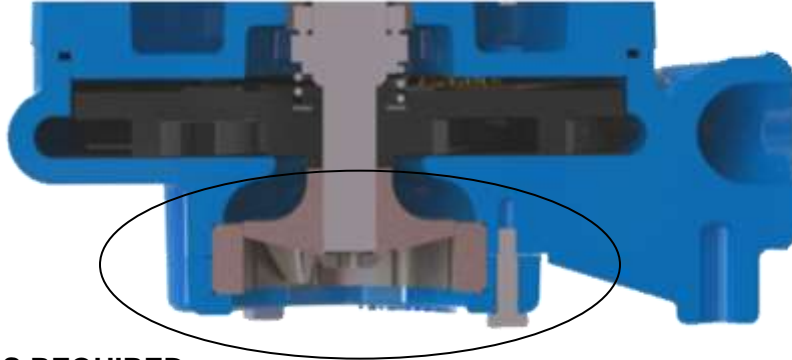

STANDARD TOOLS REQUIRED:

- Standard socket wrench set.
- Standard set of open end wrenches.
- Hammer.
- Vise grip pliers.
- Allen head socket set.
- Screwdrivers.
- Wire brush.

CAUTION – Disconnect all power and control wires to motor at the control panel before starting the disassembly operations. Do not rely upon opening the circuit breaker only.

IMPORTANT – Pump should be sanitized with bleach before starting work.

Pump should be thoroughly cleaned of trash and deposits before starting disassembly operations.

Wear protective gloves and clothing.

Always use a rag on the impeller when turning to prevent cutting hands on the sharp edges of the shredding ring.

DISASSEMBLY OF SHREDDING RING AND GRINDER IMPELLER

1. Hold the grinder impeller by prying against the impeller cutting bar and remove the allen head cap screw from the end of the shaft.
2. Use a large screwdriver in the slot end of the shaft and tap (counterclockwise) on one of the large cutter vanes with a hammer. Tap in a counterclockwise direction (thread is right hand).
3. If the impeller removes easily, clean and replace if worn.
4. Make sure the pump impeller has not loosened when the grinder impeller was removed. This can be checked on reassembly of grinder impeller and shredding ring. The tips of the impeller cutter vanes should extend 1/8" below the bottom of the shredding ring. If the distance is greater, the pump impeller has loosened. If the distance is less, the shredding ring is not properly seated.
5. After the volute case has been removed, insert screwdriver in slot end of shaft and tap hammer against the outer vane of the ductile iron pump impeller (clockwise) to ensure it is threaded tight against shoulder on shaft.
6. Use large screwdriver to tap stainless steel cutter ring from cast iron volute.
7. Clean all threads with a wire brush and file smooth any nicked threads. Use NEVER-SEEZE or other graphite compound on threads before replacing grinder impeller.

8. Make sure allen head cap screw in bottom of pump shaft is tight. Make sure the impeller turns freely by hand after reassembly. Some drag will be present due to the shaft seals. There should not be any binding or tight spots when turning the grinder impeller.

REPLACING IMPELLER AND RETAINER PLATE “AXIAL SLICERS”

**Note: This is the only disassembly operation permitted in the field.
All other repairs must be performed at an authorized service center or the factory.**

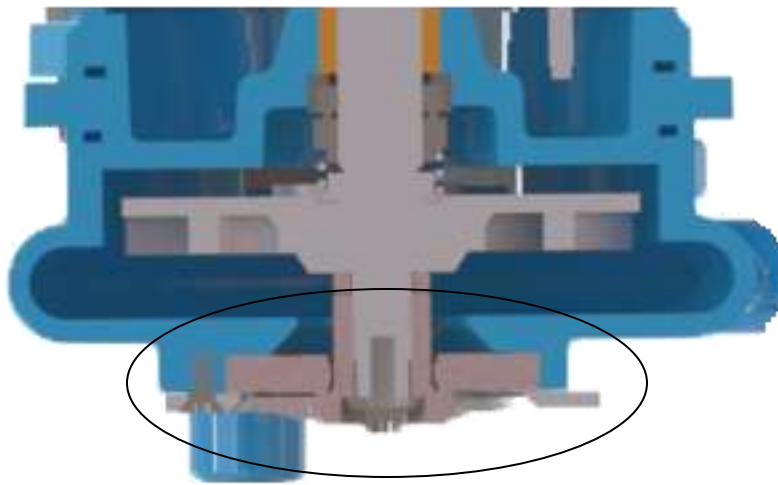

STANDARD TOOLS REQUIRED:

- Standard socket wrench set.
- Ball-peen Hammer.
- Feeler Gauges (minimum range .008-.012 inches)
- Vise grip pliers.
- Allen head socket set.
- Screwdrivers.
- Wire brush.

CAUTION – Disconnect all power and control wires to motor at the control panel before starting the disassembly operations. Do not rely upon opening the circuit breaker only.

IMPORTANT – Pump should be sanitized with bleach before starting work.

Pump should be thoroughly cleaned of trash and deposits before starting disassembly operations.

Wear protective gloves and clothing.

Always use a rag on the impeller when turning to prevent cutting hands on the sharp edges of the impeller and slicer plate.

DISASSEMBLY OR REPLACING OF SLICER PLATE AND SLICER IMPELLER

1. Remove Slicer retainer (3 bolts).
2. Use a ball-peen hammer to tap onto (3 blade) rotary slicer impeller. Tap in a counterclockwise direction (thread is right hand).
3. Remove "disk-shaped" slicer plate. May have to pry with screwdriver.
4. Once slicer plate is removed, shims will be visible on threaded shaft.
5. Slicer parts can now be cleaned and reassembled or replaced.
6. If discarding all shims, you must use new shims from shim kit.
7. Place (Qty:2) .01 inch shims onto threaded shaft, making certain to align keyway of stock with shaft.
8. Place new or cleaned slicer plate onto threaded shaft, making sure shims stay in place along keyway.
9. Place new or cleaned rotary (3 blade) slicer impeller onto threaded shaft, turning (Clockwise).
10. Rotate onto shaft with hands until snug. Use ball-peen hammer to lock onto shaft.
11. **IMPORTANT: USING FEELER GAUGES, CHECK DISTANCE BETWEEN SLICER PLATE AND SLICER IMPELLER. DISTANCE TOLERANCE (.008-.012 INCHES).**
12. If tolerance is satisfactory, go to step 13. If tolerance is beyond or under range, go back to step 7.
13. Place new or cleaned slicer retainer onto volute bottom.
14. Make sure the impeller turns freely by hand after reassembly. Some drag will be present due to the shaft seals. There should not be any binding or tight spots when turning the slicer impeller.

START KIT REPLACEMENT "C" MODEL

1. Place pump in upright position.
2. Loosen cord cap retaining bolts (A). Keen recommends that a rag or towel be wrapped around the joint where the cap and bearing housing meet (B).
3. Slowly move cord cap upward until any pressure that may be present is released, remove the retaining bolts and lift off cord cap.
4. Remove relay mounting screws (C) and replace start relay. Wire per attached diagram and reinstall.
5. Loosen retaining screws (D) and clamp (E) and replace start and run capacitors. Wire per diagram below.
6. Clean mating surfaces and inspect O-Ring (F) for cuts or damage (replace if necessary). Reinstall cord cap.
7. Check power cord at plug with ohm meter for shorts to ground.

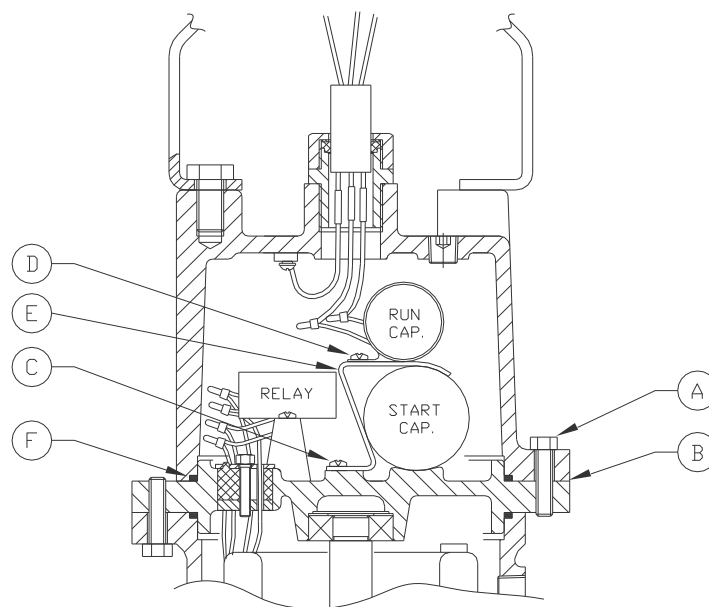

WIRING DIAGRAMS

SINGLE PHASE, 208/230/240V, 12/6 CABLE

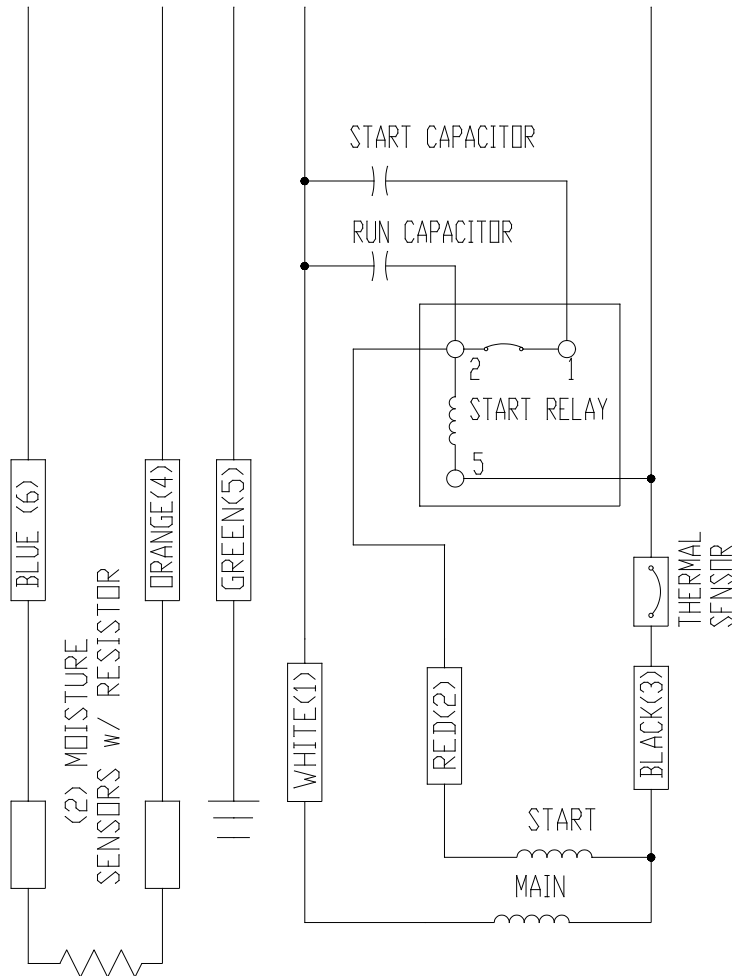

RESISTOR 330k ohm

WIRES		OHM
WHITE (1)	BLACK (3)	1.8
WHITE (1)	RED (2)	6.9
BLACK (3)	RED (2)	5.1

3-PHASE, 208/230/460V, 14/8 CABLE

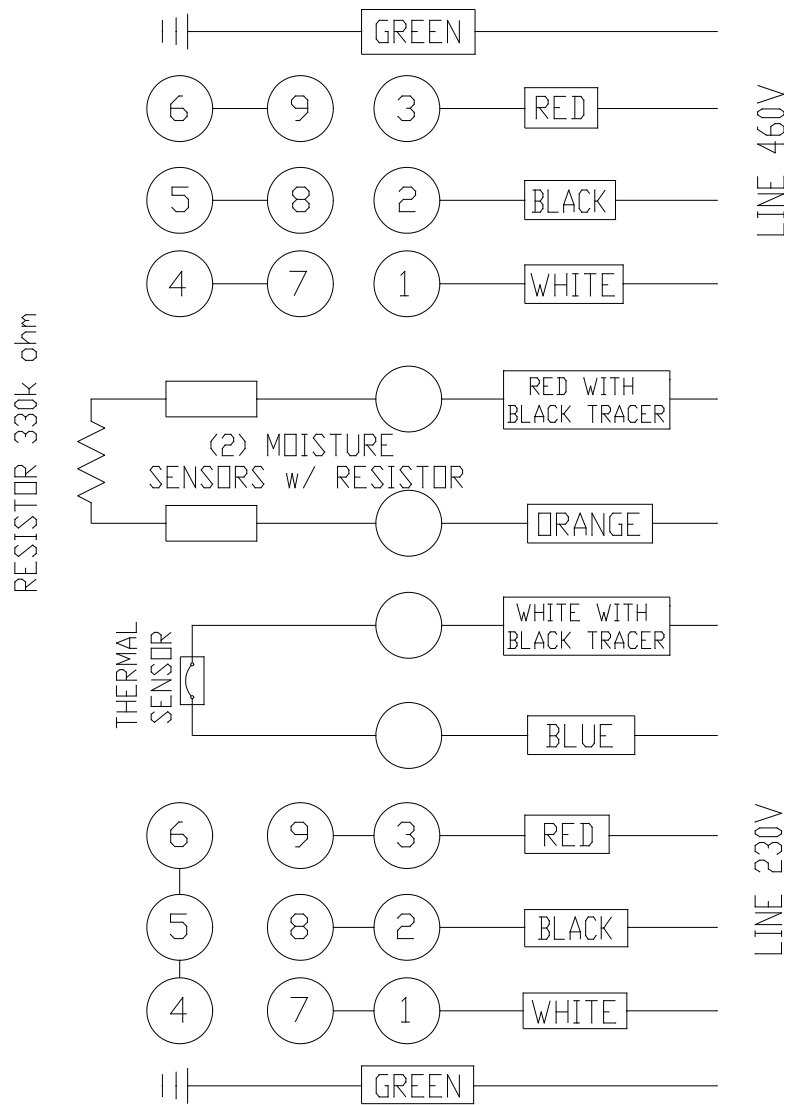

WIRES 230 VOLT		OHM
WHITE	BLACK	3.1
WHITE	RED	3.1
BLACK	RED	3.1
WIRES 460 VOLT		
WHITE	BLACK	12.4
WHITE	RED	12.4
BLACK	RED	12.4

(Internal Capacitors) SINGLE PHASE, 208/230/240V, 12/3 CABLE

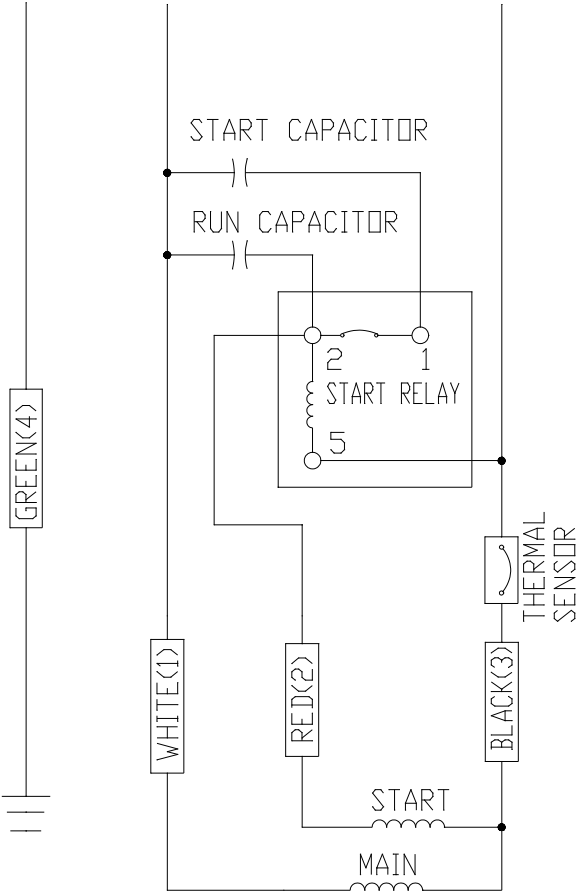

WIRES		OHM 208/230V	OHM 240V
WHITE (1)	BLACK (3)	1.2	1.6

PUMP SPECIFICATIONS

DISCHARGE.....	1-1/4" NPT & 2-bolt Connection Adapter (VERTICAL)	
LIQUID TEMPERATURE.....	120 degrees F (Continuous) 140 degrees F. (Intermittent)	
MOTOR HOUSING.....	Cast Iron, ASTM A-48, Class 30	
CORD CAP.....	Cast Iron, ASTM A-48, Class 30	
VOLUTE.....	Cast Iron, ASTM A-48, Class 30	
SEAL PLATE.....	Cast Iron, ASTM A-48, Class 30	
IMPELLER.....	Ductile Iron, ASTM A-48, Class 35B 12-vane, Vortex with Pump-out Vanes, Dynamically Balanced	
SHREDDING RING (Cutter).....	Hardened 440C Stainless Steel 56-60 Rockwell C	
GRINDER IMPELLER (Cutter).....	Hardened 440C Stainless Steel 56-60 Rockwell C	
RETAINER PLATE (Slicer).....	Hardened 440C Stainless Steel 56-60 Rockwell C	
SLICER IMPELLER (Slicer).....	Hardened 440C Stainless Steel 56-60 Rockwell C	
SHAFT.....	416 Stainless Steel	
SHAFT SEAL.....	Mechanical Main (Motor) Silicon Carbide – Rotating Face Silicon Carbide – Stationary Face Buna-N Elastomer 300 Series Stainless Steel - Hardware	Secondary (Pump) Silicon Carbide – Rotating Face Silicon Carbide – Stationary Face
BEARING (UPPER).....	Single Row, Ball, Oil Lubricated	
BEARING (LOWER).....	Single Row, Ball, Oil Lubricated	
SLEEVE BEARING	Bronze with Oil Groove	
HARDWARE.....	300 Series Stainless Steel	
O-RINGS.....	Buna-N	
CORD.....	12-3 AWG, Type SOOW ("C" Model) 12-6 AWG, Type SOOW (Single Phase) 14-8 AWG, Type SOOW (Three Phase) 30' Length Standard. Other Lengths Available.	
CORD ENTRY.....	Watertight Sealed Design Agency-Approved, Watertight Strain Relief Cord Grip – Outer Jacket Seal Epoxy Potted – Inner Conductor Seal	
MOTOR (SINGLE PHASE).....	2 HP, 3450 RPM, 60 Hz 200, 230 or 240 volts Includes Overload Protection in Motor Oil Filled, Class F Capacitor Start / Capacitor Run	
	Start Capacitor	Run Capacitor
200 Volt Models.....	216 mfd, 250 VAC	25 mfd, 370 VAC
230 & 240 Volt Models.....	216-259 mfd, 250 VAC	25 mfd, 370 VAC

MOTOR (THREE PHASE)..... 2 HP, 3450 RPM, 60 Hz
Tri-voltage, 200 / 230 / 460 volts
On-Winding temperature sensor, requires temperature sensor circuitry
in control panel
Oil Filled, Class F

OPTIONAL EQUIPMENT..... Seal Materials
Additional Cable Lengths
Impeller Trims

TROUBLESHOOTING

The troubles listed below are potential problems involving the pump. Other troubles can occur from faulty control box operation. Consult control box instructions for troubleshooting list involving the control box.

PROBLEM

Pump will not run.

PROBABLE CAUSE

Tripped breaker, blown fuse, poor electrical connection, interruption of power, improper power supply.
Float switch defective or restricted.
On single phase pumps, electronic start switch or capacitors blown.
Overload in motor tripped.
Solid material lodged in pump inlet.

Pump runs, but does not pump liquid from basin.

Pump impeller may be air locked. Start and stop pump several times to purge air. Check to ensure vent hole in volute is open and clean.
Lower "OFF" float may be set too low, allowing air into pump.
Pump inlet or valves in discharge pipe may be clogged.
Discharge valve may be closed.

Pump hums, but does not run.

Incorrect voltage.
Pump inlet plugged.
Cutter jammed or loose on shaft, worn or damaged.

Pump delivers low volume of water.

Low voltage.
On three phase pumps, motor running backwards.
Discharge restricted.
Check valve stuck closed or installed backwards.
Pump motor damaged / worn.
Pump may be air locked.
Cutter loose or jammed on shaft, worn or damaged.

Pump is noisy.

Grinder impeller may be rubbing against grinder ring due to misalignment, bent shaft or object stuck in impeller.
Grinder assembly may be partially clogged.
Pump cavitation due to low discharge pressure.

Pump cycles frequently.

Check valve stuck closed or installed backwards.
Ground water entering basin.
Fixtures are leaking.

Pump will not turn off.

Float switch defective or movement restricted.
H-O-A switch in panel is in "HAND" position.
Pump may be air locked.
Excessive inflow / pump not sized for the application.

Grease and solids accumulated in basin and will not pump out.

Pump "ON" switch may be set too high.
Debris may have accumulated around lower float weight causing pump to turn off too soon. Clean debris away from weight and cord.

Red light illuminated at control box.

Moisture detection in double seal pumps indicating service is required.
Lower seal has failed. Secondary seal still functioning.

Circuit breaker trips.

Electrical short to ground.
Check troubleshooting in control panel before pulling pump.
Check all electrical cords for damage.
Pull pump and take resistance readings of motor to determine if problem is in the pump or control box.

REPAIR PARTS LIST

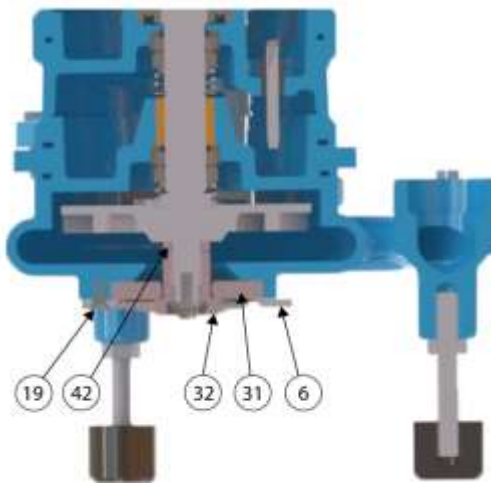
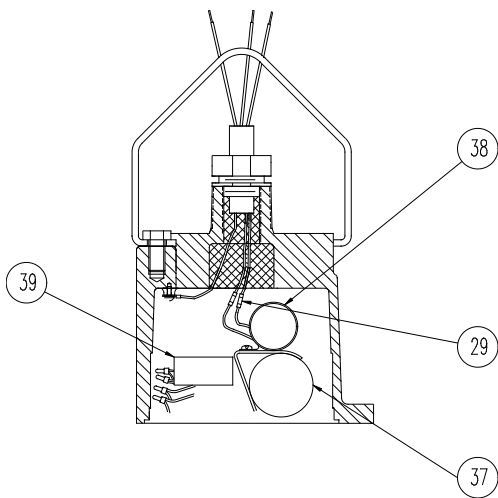
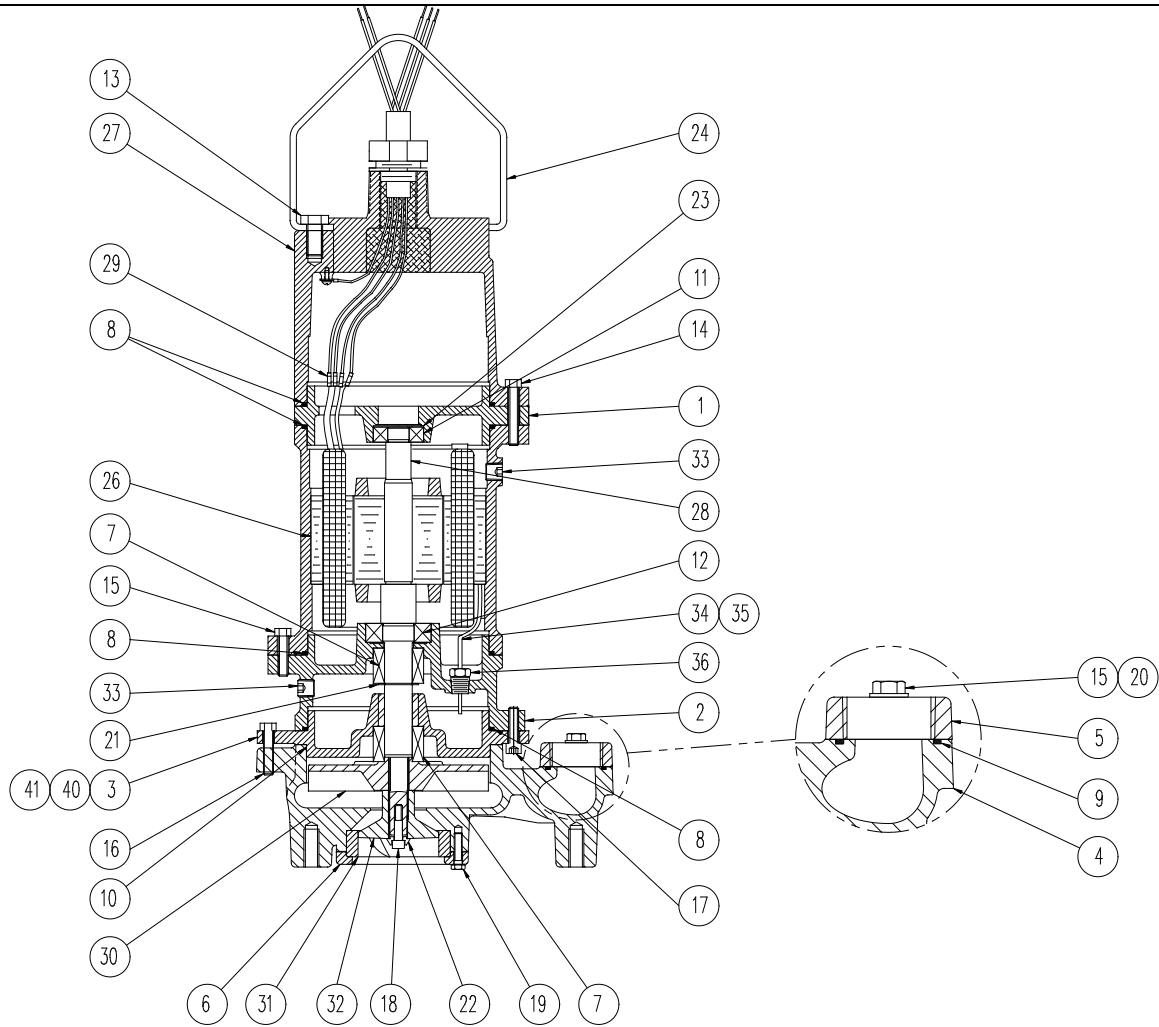

**KGX2 STYLE
"AXIAL SLICER"**

	Pump Model Numbers w/ Radial Cutters	KGX2-2001/2301/2401 (C) KFGX2-2001/2301/2401 KHGX2-2001/2301/2401 (C)		KGX2-2003/2303/4603 KFGX2-2003/2303/4603 KHGX2-2003/2303/4603	
REF. #	DESCRIPTION	QTY.	PART NUMBER	QTY.	PART NUMBER
	2 HP Castings, X proof				
1	Bearing Plate, Upper, Cast Iron	1	KGX2004	1	KGX2004
1	Assembly, Upper Bearing Plate "C" Models	1	KGX2070-5-03	-	-
2	Housing, Lower Bearing, Cast Iron	1	KGX2011	1	KGX2011
3	Seal Plate, Lower, Cast Iron	1	KGX2014	1	KGX2014
4	Volute Case, Cast Iron	1	KG2015	1	KG2015
5	Adapter, Discharge, 1-1/4" NPT, Cast iron	1	KG2026	1	KG2026
6	Flange, Grinder ring, Cast iron	1	KG2063	1	KG2063
	2 HP Repair parts				
7	Seal, Shaft, Lower and Upper, Sil. Carbide, Type 21	2	KG2172	2	KG2172
8	O-Ring, Buna-N, Motor, Cord Cap, Brg. Hsg.,5-7/8 OD	4	KG2010	4	KG2010
9	O-Ring, 2hp volute adapter, Buna-N, 1-7/8 OD	1	KG2025	1	KG2025
10	Square ring, Buna N, K(H)G Volute, 6.012 OD	1	KG2016	1	KG2016
11	Bearing, Ball, Upper Ball, 1.575OD	1	KG2003	1	KG2003
12	Bearing, Ball, 2hp LOWER, 3-7.5hp UPPER, 2.047OD	1	KG2009	1	KG2009
	2 HP Hardware & Miscellaneous parts				
13	Screw, Cap, 1/2-13UNC x 1" LG, SST	2	CS1/2X1SS	2	CS1/2X1SS
14	Screw, Cap, 5/16-18UNC x 1-3/4" LG, SST	4	CS5/16X1-3/4SS	4	CS5/16X1-3/4SS
15	Screw, Cap, 5/16-18UNC x 1-1/4" LG, SST	6	CS5/16X1-1/4SS	6	CS5/16X1-1/4SS
16	Screw, Cap, 5/16-18UNC x 1-3/8" LG, SST	4	CS5/16X1-3/8SS	4	CS5/16X1-3/8SS
17	Screw, Allen HD, 5/16-18UNC x 1" LG, SST	4	SCS5/16X1SS	4	SCS5/16X1SS
18	Screw, Allen HD, 1/4-20UNC x 5/8" LG, SST	1	SCS1/4X5/8SS	1	SCS1/4X5/8SS
19	Screw, Cap, 1/4-20UNC x 1" LG, SST	3	CS1/4X1SS	3	CS1/4X1SS
20	Washer, Flat 5/16", 300 series SST	2	WASH5/16SS	2	WASH5/16SS
21	Retaining Ring, Black- Finish Steel, External	1	KG2089	1	KG2089
22	Disc Retainer Ring, 2hp grinder impeller, 304 SST	1	KG2024	1	KG2024
23	Disc Spring, wave, steel	1	KG2118-1	1	KG2118-1
24	Handle, Lifting, SST	1	KG2017	1	KG2017
25	Oil, KEEN I.C.E. Dielectric	68 oz	K0181-1-01	68 oz	K0181-1-01
26	Assembly, Housing & Stator 200 & 230 Volt 1 ph	1	KGX2097	-	-
26	Assembly, Housing & Stator 240 Volt 1 ph	1	KGA2097-5-100	-	-
26	Assembly, Housing & Stator 200/230/460 Volt 3 ph	-	-	1	KGX2098
	Housing, motor, Cast iron	1	KGX2006	1	KGX2006
	Stator 200 & 230 Volt 1 ph	1	KG2007	-	-
	Stator 240 Volt 1 ph	1	K0477-1	-	-
	Stator 200/230/460 Volt 3 ph	-	-	1	KG2013
27	Assy, Cord Cap, 30 ft. length cord. 12/6	1	K0131-5-30	-	-
27	Assy, Cord Cap, 30 ft. length cord. 12/3 "C" Model	1	K0218-5-30	-	-
27	Assy, Cord Cap, 30 ft. length cord. 14/8	1	-	1	K0133-5-30
28	Rotor and shaft assembly 2 hp, 1 & 3 phase , Hazloc	1	KGX2096	1	KGX2096
29	Pre-insulated Crimp Wire Connector 6LU61	4	WC2-10	4	WC2-10
30	Impeller, Cast Iron, Standard Flow & "C" Model	1	KG2018-01	1	KG2018-01
30	Impeller, Cast Iron, High Flow	1	KG2018-02	1	KG2018-02
30	Impeller, Cast Iron, High Head & "C" Model	1	KG2018-04	1	KG2018-04
31	Ring, Grinder, SST, Standard Flow & "C" Model	1	KG2149-2-01	1	KG2149-2-01
31	Ring, Grinder, SST, High Flow	1	KG2115-11	1	KG2115-11
31	Ring, Grinder, SST, High Head & "C" Model	1	KG2072-2-01	1	KG2072-2-01
32	Impeller, Grinding, SST	1	KG2019-2-01	1	KG2019-2-01
33	Plug, 1/4" NPT pipe, SST	4	PLUG1/4	4	PLUG1/4
34	Assy, Wire, Moisture Detector w/ resistor	1	K0138-1-01	1	K0138-1-01
35	Resistor, 330k ohm	1	K0381-1-01	1	K0381-1-01

36	Sensor, Moisture	1	KG2160	1	KG2160
37	Capacitor, Start, 216 Mfd, 250 VAC	1	KG2134	-	-
38	Capacitor, Run, 25 Mfd, 370 VAC	1	KG2138	-	-
39	Assembly, Start switch (230 volt)	1	K0653-5-01	-	-
40	Lower bearing plate assembly	1	KGX2011	1	KGX2011
41	Bushing, bronze, 48 FRM grinder	1	KGX2014-B	1	KGX2014-B
42	Assy, Wire, Moisture Detector w/ resistor	1	K0138-1-01	1	K0138-1-01
43	Sensor, Moisture	1	KG2160	1	KG2160
44	Spacer, Slicer Impeller, SST, .250"	1	K0546-3-01	1	K0546-3-01

	Pump Model Numbers w/ Axial Slicers	KGX2SL-2001/2301/2401(C) KHGX2SL- 2001/2301/2401(C)		KGX2SL-2003/2303/4603 KHGX2SL-2003/2303/4603	
REF. #	DESCRIPTION	QTY.	PART NUMBER	QTY.	PART NUMBER
	2 HP Castings, X proof				
1	Bearing Plate, Upper, Cast Iron	1	KGX2004	1	KGX2004
2	Housing, Lower Bearing, Cast Iron	1	KGX2011	1	KGX2011
3	Seal Plate, Lower, Cast Iron	1	KGX2014	1	KGX2014
4	Volute Case, Cast Iron	1	KG2015-2-100	1	KG2015-2-100
5	Adapter, Discharge, 1-1/4" NPT, Cast iron	1	KG2026	1	KG2026
6	Retainer, Slicer Plate, SST	1	K0453-1-01	1	K0453-1-01
	2 HP Repair parts				
7	Seal, Shaft, Lower and Upper, Sil. Carbide, Type 21	2	KG2172	2	KG2172
8	O-Ring, Buna-N, Motor, Cord Cap, Brg. Hsg., 5-7/8 OD	4	KG2010	4	KG2010
9	O-Ring, 2hp volute adapter, Buna-N, 1-7/8 OD	1	KG2025	1	KG2025
10	Square ring, Buna N, K(H)G Volute, 6.012 OD	1	KG2016	1	KG2016
11	Bearing, Ball, Upper Ball, 1.575OD	1	KG2003	1	KG2003
12	Bearing, Ball, 2hp LOWER, 3-7.5hp UPPER, 2.047OD	1	KG2009	1	KG2009
	2 HP Hardware & Miscellanies parts				
13	Screw, Cap, 1/2-13UNC x 1" LG, SST	2	CS1/2X1SS	2	CS1/2X1SS
14	Screw, Cap, 5/16-18UNC x 1-3/4" LG, SST	4	CS5/16X1-3/4SS	4	CS5/16X1-3/4SS
15	Screw, Cap, 5/16-18UNC x 1-1/4" LG, SST	6	CS5/16X1-1/4SS	6	CS5/16X1-1/4SS
16	Screw, Cap, 5/16-18UNC x 1-3/8" LG, SST	4	CS5/16X1-3/8SS	4	CS5/16X1-3/8SS
17	Screw, Allen HD, 5/16-18UNC x 1" LG, SST	4	SCS5/16X1SS	4	SCS5/16X1SS
18	Screw, Allen HD, 1/4-20UNC x 5/8" LG, SST	1	SCS1/4X5/8SS	1	SCS1/4X5/8SS
19	Screw, Cap, C-sunk, 1/4-20UNC x 5/8" LG, SST	3	K0317-1-02	3	K0317-1-02
20	Washer, Flat 5/16", 300 series SST	2	WASH5/16SS	2	WASH5/16SS
21	Retaining Ring, Black- Finish Steel, External	1	KG2089	1	KG2089
22	Disc Retainer Ring, 2hp grinder impeller, 304 SST	1	K0558-3-01	1	K0558-3-01
23	Disc Spring, wave, steel	1	KG2118-1	1	KG2118-1
24	Handle, Lifting, SST	1	KG2017	1	KG2017
25	Oil, KEEN I.C.E. Dielectric	68 oz	K0181-1-01	68 oz	K0181-1-01
26	Assembly, Housing & Stator 200 & 230 Volt 1 ph	1	KGX2097	-	-
26	Assembly, Housing & Stator 240 Volt 1 ph	1	KGA2097-5-100	-	-
26	Assembly, Housing & Stator 200/230/460 Volt 3 ph	-	-	1	KGX2098
	Housing, motor, Cast iron	1	KGX2006	1	KGX2006
	Stator 200 & 230 Volt 1 ph	1	KG2007	-	-
	Stator 240 Volt 1 ph	1	K0477-1	-	-
	Stator 200/230/460 Volt 3 ph	-	-	1	KG2013
27	Assy, Cord Cap, 30 ft. length cord. 12/6	1	K0131-5-30	-	-
27	Assy, Cord Cap, 30 ft. length cord. 12/3 "C" Model	1	K0218-5-30	-	-
27	Assy, Cord Cap, 30 ft. length cord. 14/8	1	-	1	K0133-5-30
28	Rotor and shaft assembly 2 hp, 1 & 3 phase , Hazloc	1	KGX2096	1	KGX2096
29	Pre-insulated Crimp Wire Connector 6LU61	4	WC2-10	4	WC2-10
30	Impeller, Cast Iron, Standard Flow & "C" Model	1	KG2018-01	1	KG2018-01
30	Impeller, Cast Iron, High Head & "C" Model	1	KG2018-04	1	KG2018-04
31	Plate, Slicer, SST, Standard Flow & "C" Model	1	K0452-2-01	1	K0452-2-01
31	Plate, Slicer, SST, High Head & "C" Model	1	K0452-2-100	1	K0452-2-100
32	Impeller, Slicer, SST	1	K0454-2-100	1	K0454-2-100
33	Plug, 1/4" NPT pipe, SST	4	PLUG1/4	4	PLUG1/4
34	Assy, Wire, Moisture Detector w/ resistor	1	K0138-1-01	1	K0138-1-01
35	Resistor, 330k ohm	1	K0381-1-01	1	K0381-1-01
36	Sensor, Moisture	1	KG2160	1	KG2160
37	Capacitor, Start, 216 Mfd, 250 VAC	1	KG2134	-	-
38	Capacitor, Run, 25 Mfd, 370 VAC	1	KG2138	-	-

39	Assembly, Start switch (230 volt)	1	K0653-5-01	-	-
40	Lower bearing plate assembly	1	KGX2011	1	KGX2011
41	Bushing, bronze, 48 FRM grinder	1	KGX2014-B	1	KGX2014-B
42	Spacer, Slicer Impeller, SST, .250"	1	K0546-3-01	1	K0546-3-01



471 US Hwy 250 East, Ashland, Ohio 44805
PH: 419-207-9400 FX: 419-207-8031

Limited Warranty

During the time periods and subject to the conditions hereinafter set forth, Keen Pump will repair or replace to the original user or consumer, any portion of your new Keen product which proves defective due to defective materials or workmanship of Keen Pump. Contact your closest authorized Keen Pump representative or distributor for warranty service. At all times, Keen Pump shall have and possess the sole right and option to determine whether to repair or replace defective equipment, parts or components. Damage caused by acts of GOD or conditions beyond the control of Keen Pump is not covered by this warranty.

WARRANTY PERIOD:

36 months from date of manufacture.

Start-up reports are required to support warranty claims. Warranty effective only if Keen Pump supplied or authorized control panels are used. Single phase pumps must utilize Keen Pump supplied start components.

THIS WARRANTY WILL NOT APPLY:

- (1) To defects or malfunctions resulting from failure to properly install, operate or maintained the product in accordance with printed instructions provided.
- (2) To failures resulting from abuse, accident or negligence.
- (3) To normal maintenance services and the parts used in conjunction with such service.
- (4) To products which are not installed in accordance with applicable local codes, ordinances and good trade practices.
- (5) The product is used for purposes other than for what is was designed and manufactured.
- (6) If 3 phase motors are installed on a single phase power supply using a phase converter or if 3 phase power is supplied by only two transformers, making an open Delta system.

WARRANTY EXCLUSIONS:

Keen Pump specifically disclaims the implied warranties of merchantability and fitness for a particular purpose after the termination of the warranty period set forth herein. No warranties or representations at any time made by any representatives of Keen Pump shall vary or expand the provision hereof.

LIABILITY LIMITATION:

In no event shall Keen Pump be liable or responsible for consequential, incidental or special damages resulting from or related in any manner to any Keen Pump product or parts thereof. Personal injury and/or property damage may result from improper installation. Keen Pump disclaims all liability, including liability under this warranty, for improper installation. Keen Pump recommends following the instructions in the installation manual. When in doubt, consult a professional. Some states do not allow the exclusion or limitation of incidental or consequential damages, so the above limitation or exclusion may not apply to you.

LABOR, ETC., COSTS:

Keen Pump shall in no event be responsible or liable for the cost of field labor or other charges incurred by any customer in removing and/or reaffixing any Keen Pump product, part or component thereof or any temporary pumping of other equipment.

RETURNED OR REPLACED COMPONENTS:

Any item to be replaced under this Warranty must be returned to Keen Pump, or such other place as Keen Pump may designate, freight prepaid.

This warranty gives you specific legal rights and other rights which may vary from state to state.

In the absence of suitable proof of this purchase date, the effective date of this warranty will be based upon the date of manufacture. Example: 0105 = Month-Year = January, 2005.

P/N O&M-KGX2GRINDER