

APPROVED BY: \_\_\_\_\_  
 DATE: \_\_\_\_\_

TO CUSTOMER: EXAMINE THIS DRAWING CAREFULLY. VERIFY ALL DIMENSIONS, LOCATIONS, AND ELEVATIONS FOR ACCURACY. SIGN AND DATE AT LINE. ANY MODIFICATIONS OR CHANGES TO THIS DRAWING OR FINISHED PRODUCT, AFTER IT HAS BEEN SIGNED, MAY RESULT IN ADDITIONAL CHARGES AND SHIPPING DELAYS. NO JOB WILL BE STARTED UNTIL CONFIRMATION THROUGH SIGNATURE RELEASES ORDER FOR PRODUCTION.

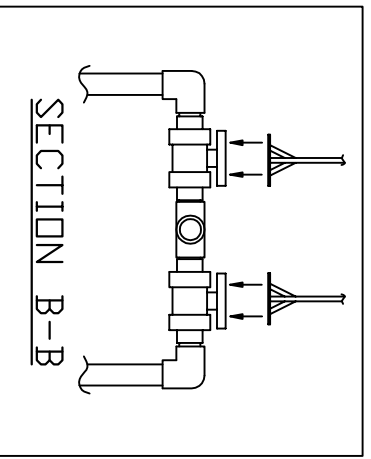
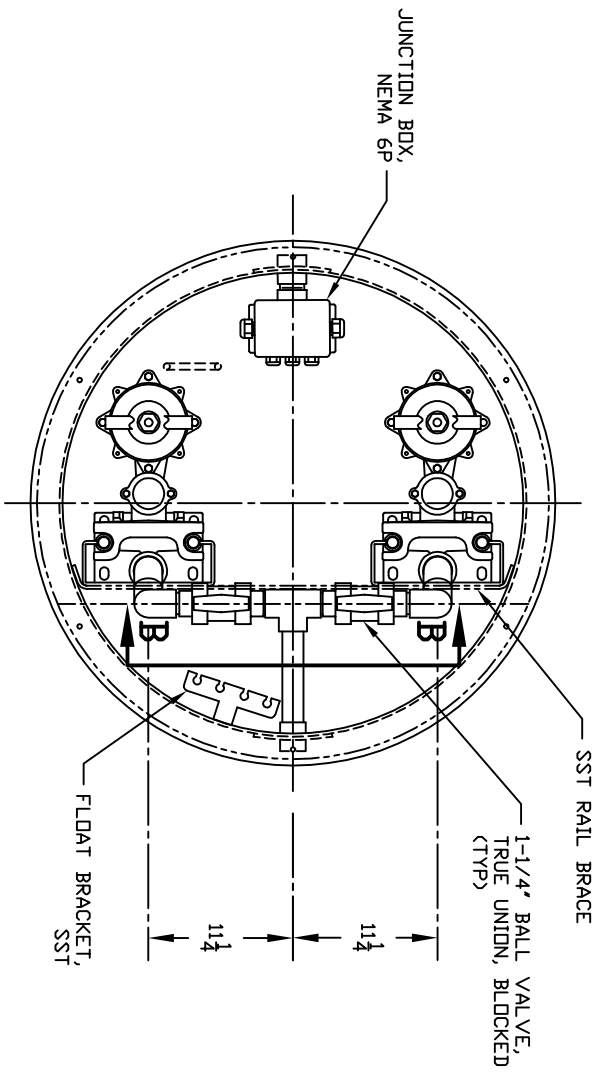
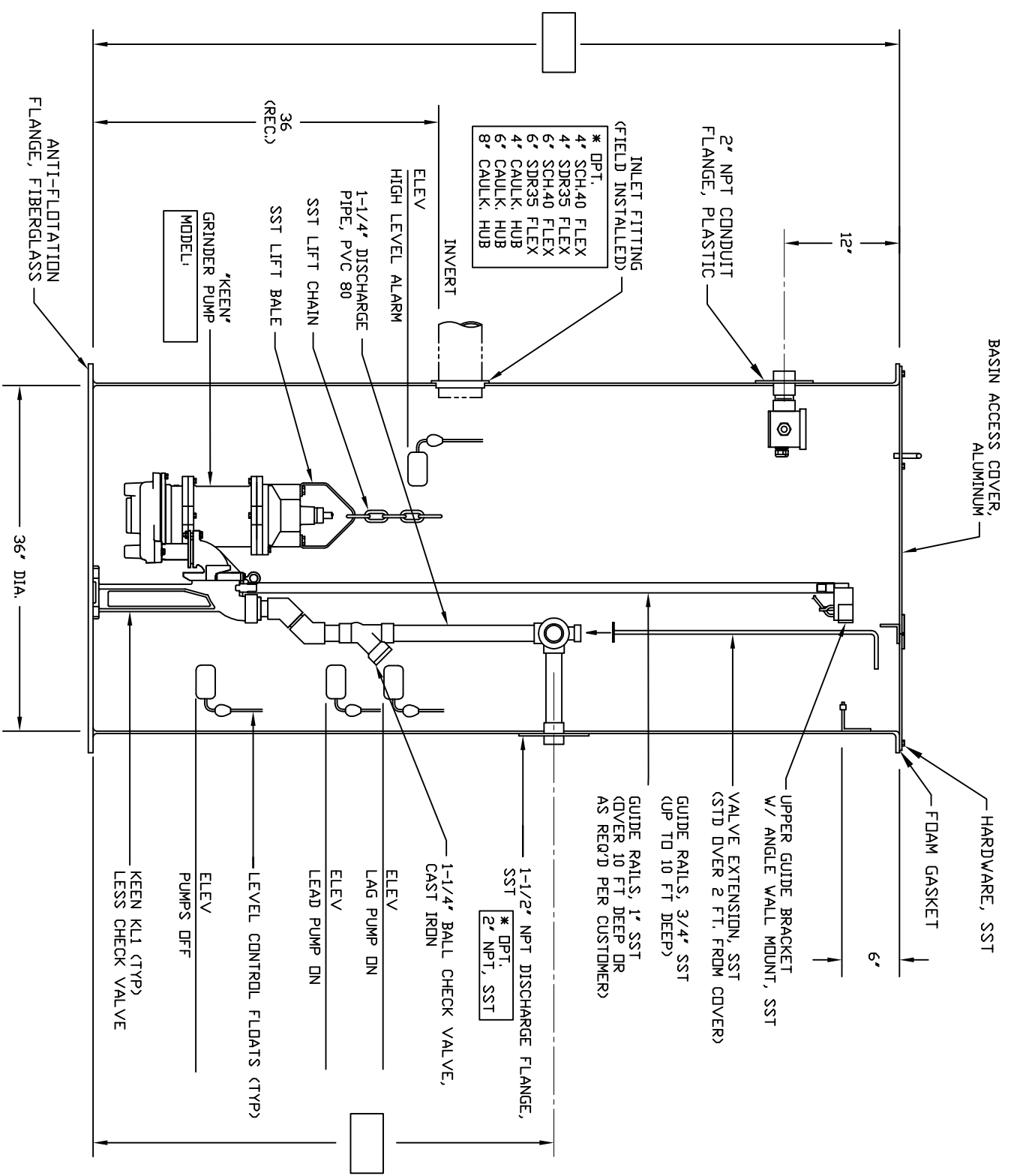

NOTE: ALL DIMENSIONS FOR REFERENCE ONLY

REV	INITIALS	DATE

**KEEN PUMP COMPANY**  
 KEEN PUMP CO.  
 471E ST. ROUTE 260 EAST  
 ASHLAND, OHIO 44805  
 PHONE: 419-207-9400  
 FAX: 419-207-8031

TITLE: BASIN ASSY: 36" DIA., ALL 182HP GR., DUP., KL1, ALUM. COVER  
 SCALE: NTS  
 DWG. BY: SE  
 DATE: 01/08/13  
 DWG. #: KN-676  
 REV: -